

LG HVAC SOLUTION

WATER COOLED SCREW CHILLER

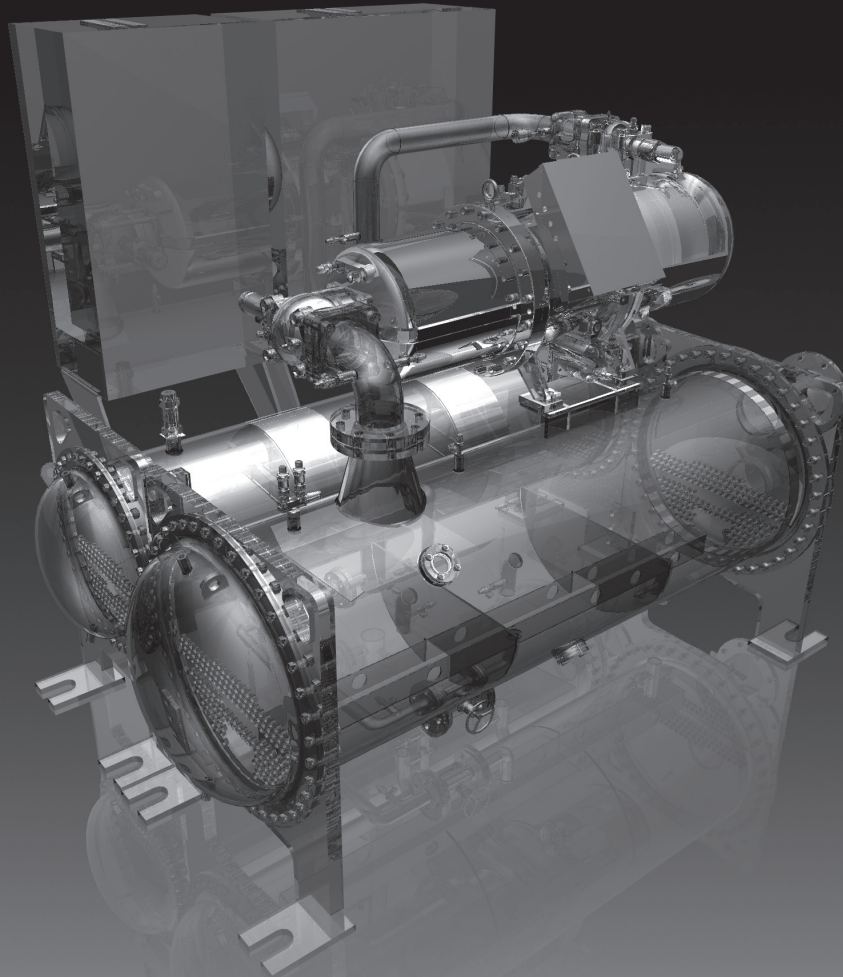

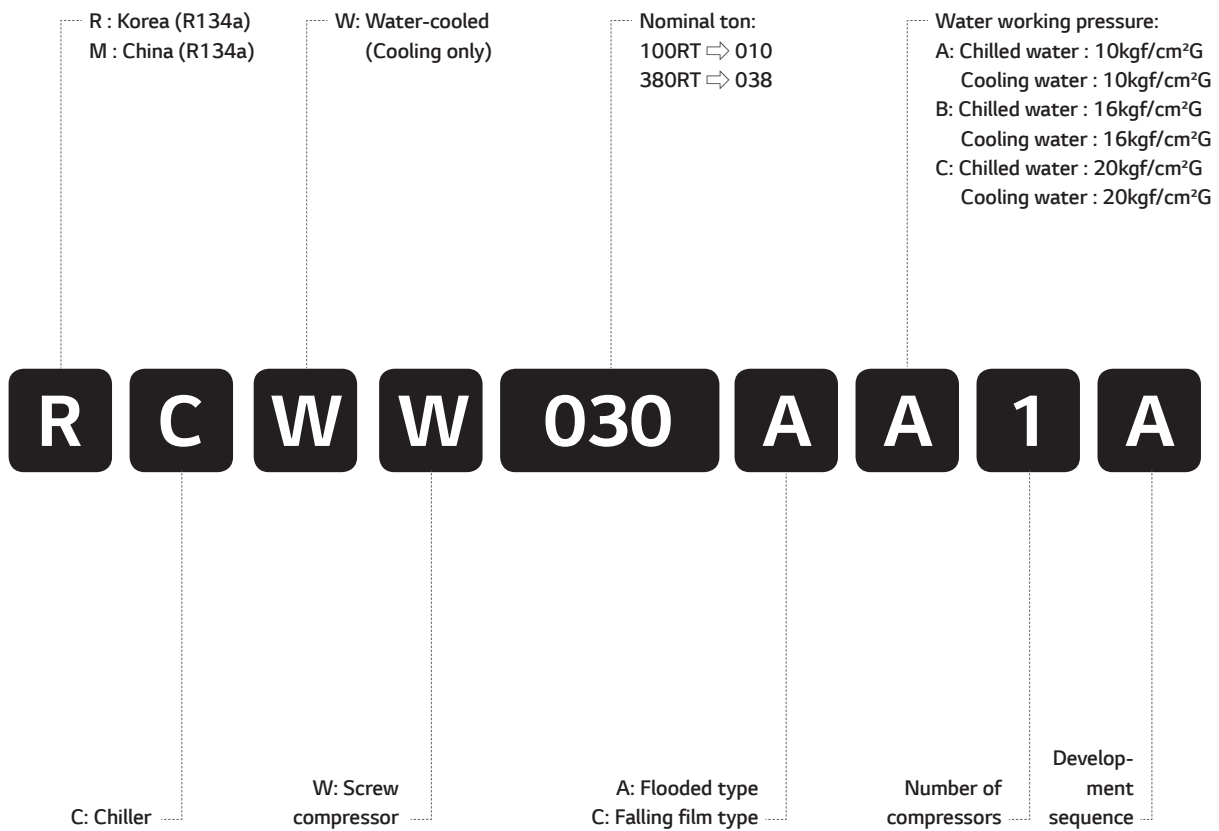

Contents

- 02 Nomenclature
- 03 Line up & Introduction
- 04 Equipment overview
- 06 Control
- 08 Accessories and options
- 09 Specification
- 13 Performance data
- 19 Electrical data
- 26 Outline drawing
- 28 Foundation
- 30 Piping diagram
- 32 Control wiring
- 34 Power wiring
- 36 Guide specification

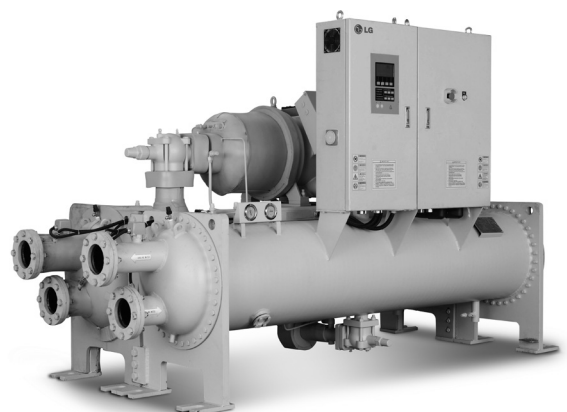

Line up

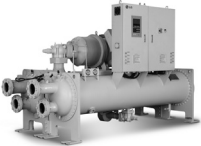
Model			50	100	150	200	250	300	350	400
	R-134a	60Hz		74RT ————— 373RT						
		50Hz		75RT ————— 364RT						

* The above range is based on the nominal tonnage.

LG's latest Water cooled screw chiller offers excellent operational efficiency thanks to the company's advanced technologies and unrivalled air conditioning expertise. The new model's advanced capacity control system valve help to improve performance and efficiency. LG's proprietary PID (Proportional, Integral, Differential control), which controls hydraulic-head loss rate, helps to minimize energy loss even further.

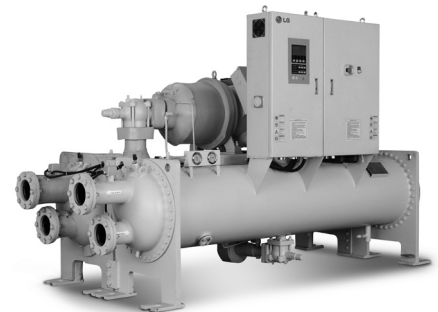

- High-performance compressor manufactured by specialized manufacturer is adopted to ensure that the chiller is economical and durable with low vibration and low noise.
- Highly integrated motherboard is adopted and hence the function is strong and reliable.
- Advanced control algorithm is adopted to control chiller in advance and hence avoid frequent stoppage protection of chiller.
- We have set complete safety protection function in order to make chiller safely and reliably run.
- The linkage control and remote monitoring function of peripheral equipment ensure that the chiller can run safely and the operation and monitoring are convenient.
- The selection of excellent raw materials and fittings is the key to guaranteeing chiller quality.

High efficiency, High reliability

The RCWW & MCWW series is a kind of water-cooled spray screw chiller produced by LGE Corporation. Because of the special structure design, the chiller has high efficiency and high reliability.

Optimized dedicated motor R134a with high efficiency

Made of premium grade, low-loss core steel with the special slot design, the motors of R134a dedicated compressors

can gain the highest efficiency with low power consumption. Besides, different winding for specific voltage and frequency requirement contributes to the best power factor and excellent performance.

Constructional design of dedicated screw compressor

The screw compressor is characterized by a very compact design. Most of inner dimensions have been totally modified considering displacement volume, size of compression chamber, length & profile of rotors, oil separator specification and oil piping rearrangement, etc. to ensure consistency and cost effectiveness of the compressor.

Compressor

- Semi-hermetical twin-rotor screw compressor.
- Direct-drive, low speed/RPM for high efficiency and high reliability.
- Only three moving parts, resulting in high reliability with simple solution.
- Field serviceable compressor and easy maintenance.
- Precise rotor tip clearance.
- The world's advanced patent screw tooth with low noise, smooth operation long life advantages.
- A refrigerant dispersing cooling device is set internally for compressor cooling, which uses return-refrigerant cooling.
- Years of research and testing. The LG screw chiller has amassed thousands of hours of testing, and conditions

beyond normal air conditioning applications.

Unit performance testing

LG began promoting factory performance tests for air-cooled chillers and water-cooled chillers, to show we stand behind the products we design and build.

The benefits of a performance test include verification of performance, prevention of operational problems, and assurance of a smooth start-up.

Only a performance test conducted in a laboratory or laboratory grade facility will confirm both performance and operation of a specific chiller.

Mostly factory performance tests go smoothly. If a problem occurs, LG personnel easily correct them and chiller is shipped to job site.

When a factory performance test is requested, the test can be conducted at the specified, design conditions. The test facility has the capability to control ambient test conditions to assure our customers that our chillers will perform as predicted.

AHRI certification program and standards and codes

Chillers conform to the following Standards and Codes:

- AHRI 550/590 - water chilling packages using the vapor compression cycle.
- ANSI/ASHRAE 34 - number designation and safety classification of refrigerants.
- AASME Section VIII (Option) - boiler and pressure vessel.
- GB/T 18430.1 - water chilling (heat pump) packages using the vapor compression cycle - part 1: water chilling (heat pump) packages for industrial & commercial and similar applications. (This code is only applied to product manufactured in China)



Equipment Overview

Semi-hermetic twin compressor

The semi-hermetic screw compressor is developed especially for applications in air-conditioning and refrigeration. With high operating load design, each compressor is of high efficiency and reliability in all operating conditions. Each compressor has the latest and advanced 5-to-6 Patented Screw Rotor Profile designed to ensure high capacity and efficiency in all operating conditions.

The compressor is equipped with separated radial and axial bearings, liquid injection and economizer connection, PTC motor temperature thermistors and discharge temperature thermistors, a motor protector, and oil level switch and

oil pressure differential switch and other accessories. The complete accessories and their new designs guarantee the compressor has the best reliability, longest bearing life during heavy duty running and strict operating conditions.

The slide valve for capacity control is located in the compressor chamber. The slide valve is actuated by injection of pressurized oil into the cylinder from the oil sump as well as bypass of oil through solenoid valves in each oil lines with pressure differential.

The screw compressors are equipped with either 3-step/4-step capacity control system or continuous (stepless) capacity control system. Both of the capacity control systems consist of a modulation slide valve, piston rod, cylinder, piston and piston rings. The slide valve and the piston are connected by a piston rod. The principle of operation is using the oil pressure to drive the piston in the cylinder. The lubrication oil flows from the oil sump through the oil filter cartridge and capillary then fills into the cylinder due to the positive oil pressure bigger than the right side of spring force plus the high pressure gas. The positive pressure differential causes the piston to move toward the right side in the cylinder. When the slide valve moves toward the right side, the effective compression volume in the compression chamber increases. This means the displacement of refrigerant gas also increases, as a result the refrigeration capacity also increases.

However, when any of the step solenoid valve (for 4-step capacity control system) is opened, the high pressure oil in the cylinder bypasses to the suction port, which causes the piston and the slide valve to move toward the left side, and then some of the refrigerant gas bypasses from the compression chamber back to the suction end. As a result, the refrigeration capacity decreases because of the reduction of displacement of refrigerant gas flowing in the system. The piston spring is used to push the piston back to its original position, i.e. minimum load position in order to reduce the starting current for the next starting.

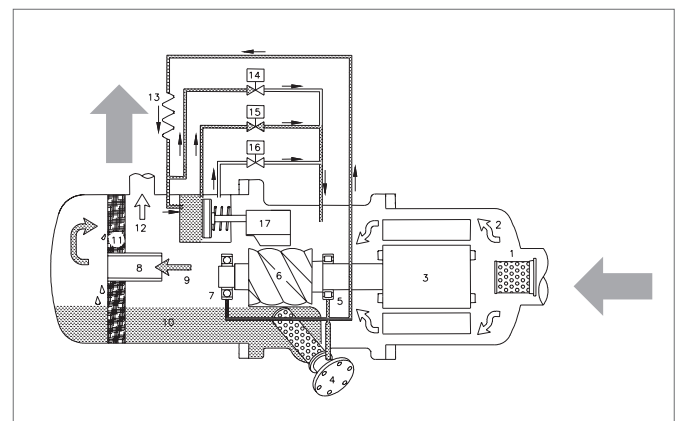

4-steps capacity control

No	Component	No	Component
1	Suction filter	10	Lubricant
2	Gas in (low pressure)	11	Oil separator cartridge
3	Motor	12	Gas out (high pressure without oil)
4	Oil filter cartridge	13	Capillary
5	Suction bearings	14	Solenoid valve, SV2
6	Male rotor	15	Solenoid valve, SV1
7	Discharge bearings	16	Orifice
8	Oil separator baffle	17	Slide valve
9	Gas out (high pressure with oil)		

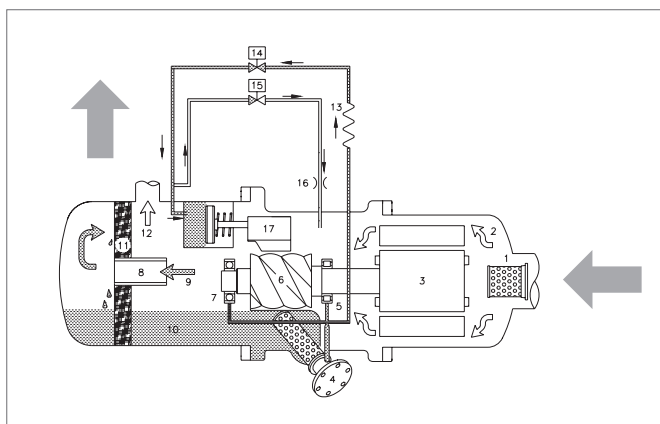

Step-less capacity control

No	Component	No	Component
1	Suction filter	10	Lubricant
2	Gas in (low pressure)	11	Oil separator demister
3	Motor	12	Gas out (high pressure without oil)
4	Oil filter cartridge	13	Capillary
5	Suction bearings	14	Solenoid valve (min. %), SV 25% / 33%
6	Male rotor	15	Solenoid valve (50% of full load), SV 50%
7	Discharge bearings	16	Solenoid valve (75% / 66% of full load), SV 75% / 66%
8	Oil separator baffle	17	Slide valve
9	Gas out (high pressure with oil)	*	For RC2-100, 140 & 180 the SV50% omitted

Heat exchanger

Evaporator

Falling film type

"Falling film" shell and tube type evaporator having refrigerant in the shell and chilled water inside the tubes.

Advantage of this type evaporator is higher heat transfer performance and reduced refrigerant charge.

Distributor located on the top side of inside shell makes uniform flow of refrigerant, this refrigerant flows downward by gravity as a continuous film.

The shell is of welded carbon steel construction with steel

tube sheets and copper heat exchange tubes. Removable steel water boxes at both ends of the cooler allow tube cleaning without disturbing the refrigerant circuit.

Tubes are mechanically expanded into tube sheets with double grooves to ensure leak tight and trouble free operation. Multiple compressor/ circuit chillers have coolers with separate refrigeration circuits for each compressor.

Each refrigeration circuit is provided with its own pressure relief valve. All chillers are fitted with drain valves on the removable heads and shell. All coolers are factory insulated with 19mm of closed cell expanded synthetic rubber with all joints vapor sealed.

Expansion device

Expansion unit consists of butterfly valve and orifice. At 100% load situation, the pressure loss at the orifice is smaller than the refrigerant pressure loss in the condenser, thus the super-cooled refrigerant passes through the orifice.

At this stage the maximum amount of refrigerant is flowing into the evaporator. As the load reduces gradually, the circulating amount of refrigerant also reduces and accordingly the refrigerant level in the condenser is getting low.

When the amount of liquid refrigerant reduces, the gas amount in the orifice is getting larger, raising the resistance thus controlling the flow rate.

Control

Control Panel Layout

Function

HMI with 7 inch Color LCD is composed as a graphic type. There are start/stop, control valve 2 and Compressor 2, compressor, lead/lag lamp, and chilled water / coolant flow lamp keys. There are 'function keys' at the bottom of the screen that change according to the current screen to be able to access lower categories.

The Display of screw chiller's control unit consists of; basic screen where present operation can be checked, and main menu which user can use conveniently for user setting, problem/warning information check, and system menu which is for sensor setting and system pertain item setting.

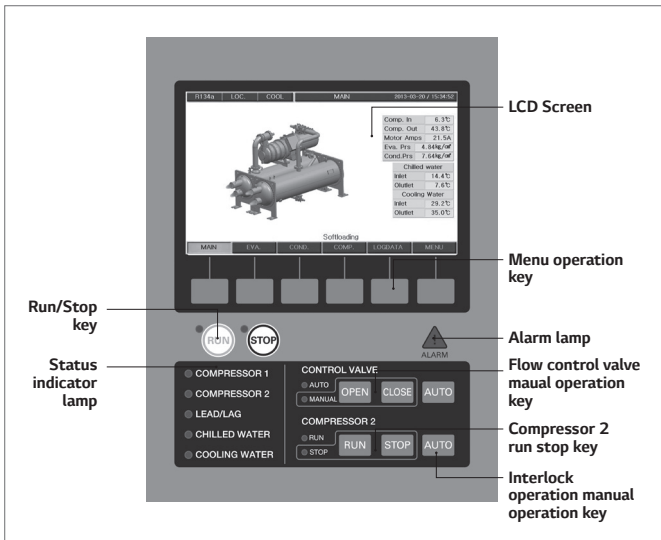

Controller front view

the high reliability chiller operation using LG's unique optimum control algorithm.

Our controller unit has the following features.

1. 7 inch Color wide LCD Display (800x480 Graphic)
2. Remote operation/stop function which allows the chiller to be operated remotely.
3. Scheduled operation function which allows setting the operation time period in holiday and weekdays.
4. Soft loading function for the low load startup
5. Various preventive control function for preventing overload, condenser high pressure, evaporator low pressure, surge, etc.
6. Advanced control function for the optimum control
7. Improved control function to protect the chiller
8. Self diagnosis function for easy checking of abnormal situation
9. Help function describing actions to take when problem occurs
10. Operation data and operation status (error and control action) saving function
11. Automatic sensor setting function to set the sensors automatically (set by software)
12. Automatic repeat key function for setting values easily
13. Modbus protocol communication function for remote surveillance control
 - RS485: Standard installation
 - BACnet & RS232C: Optional
14. Graphictrend function showing the chilled water outlet temperature and operation current change in real time.
15. Print function for printing operation or problem data (Optional)
16. Cooling tower fan control function for keeping stable cooling water temperature
17. Interlock check function for checking peripherals and malfunction
18. Time display function showing number of operations and total run time of the pump and motor which are attached to main body.

Names of operation unit

Name	Description
LCD screen	It is the color LCD(Liquid Crystal Display) showing operation information and status as in text(Korean, English, Chinese) or animation graphic.
Menu operation key	It is the key to operate menu displayed on the LCD, such as, selection of the displaying screen or setting of operation condition, etc. The functions of the operation keys are displayed at the bottom of the LCD screen, and the functions of the operation key changes as with the screens selected.
Flow control valve manual operation key	It is the key to operate(open/close) the solenoid valve manually. When "Valve manual" indicator lamp is on, it is the state where that manual operation is possible. Open/close key operates only when the key is pressed down.
Interlock control manual operation key	It is the key to Run/Stop interlock control manually. When "interlock control status" indicator lamp is off, it is the state that manual operation is possible, and it starts to operate when it is pressed down for about 1.5 seconds or longer.
Alarm lamp	When a problem or caution warning occurs the alarm lamp is turned on. When the alarm lamp is on, the message on about the alarm is displayed on the message display line in the LCD screen. At this time, therelease key shows up and buzzer will sounds. If you press the release key at this time, the buzzer will stop and the release key will disappears. And when the problem alarm disappears, the message will also disappears.
Run/Stop key	It is the key to Run/Stop the chiller. It works when you press it down for about 1.5 seconds or longer, and run indicator lamp is on during running, and stop indicator lamp is on when it is stopped.
Compressor 2 Run/Stop key	It is used when 2 compressors are operated. It is the key to Run/Stop the second compressor. In the product where 2 compressors are installed, it is used as the Run/Stop key of the compressor 2. It displays the Run/Stop status of the chiller and devices attached to the chiller and as well as status of the chilled water, cooling water, and flow rate. The indicator lamp is on when it is operated.

Controller system composition diagram

Master, slave, HMI, Relay board communicates with RS485, and in one master/slave board, there are analog input (temp. 12 channel, current 10 channel), analog output (current 4 channel), digital input (20 channel), digital output (16 channel). Relay board controls Solenoid valve in 2 comp.

BMS support function

Screw chiller's basic communication protocol is Modbus protocol, and it is compatible with the higher level communication methods.

Communication protocol support

- Communication method
 - Basic: RS-485, Ethernet(Optional)
- Protocol
 - Basic: MODBUS

Features of control unit

The Control unit of LG chiller controls temperature, pressure, flow rate, current, voltage, power and capacity control valve using high capacity microprocessor. It is constructed to provide

- Option: BACnet, TCP/IP

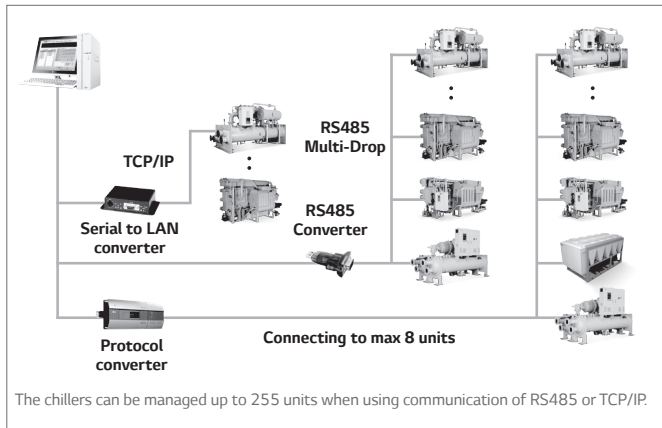

Detailed diagrams of BMS

Provide equipment with power factor correction capacitors as required to maintain a displacement power factor of 95% at all load conditions.

NFB (Non-Fused Breaker) power disconnect switch

A non-fused disconnect is available as a factory-installed option for all units with single point power connection units. This option is that power supply is disconnected during service & repair work as well as door interlock.

Suction service isolation valve

Service suction isolation valve is installed with unit for each refrigerant circuit as a standard.

Accessories and options

Compressor acoustic enclosure

The compressor acoustic enclosure can be provided as an option to reduce compressor sound levels. This enclosure is constructed of painted panels and sound absorbing insulation for maximum sound attenuation.

The panels and the sound foam, provide sound damping effect. This panel fastened with bolt for service. The enclosure is factory installed option.

Evaporator options

Double thickness insulation

As a standard, the evaporator shell is insulated with 3/4" (19mm). As an option, it can be insulated with 1-1/2" (38mm).

General options

Flow switch accessory

Water flow detection switch is should be installed to detect water flow. The water flow switch comes with SPDT(Single Pole Double Throw) output function, 1.6MPa (232 psi) working pressure, -10°C to 120°C (-14°F to 248°F) with 1" NPT connection for upright mounting in horizontal pipe (This flow switch or equivalent must be furnished with each unit). Field mounted.

Vibration isolation

For installation on building roofs or in sensitive noise areas (hospitals, studios and some residential areas) pre-selected spring type isolators with 1" or 2" deflection are available as a factory option – shipped loose part for field installation.

Power factor correction

Category	Optional list	Standard	Option	Remark
Refrigerant	Factory charging		√	
Operation temperature	Leaving chilled water	√		5~15°C
	Entering cooling water	√		18~35°C
BMS Interface	Modbus	√		
Heat exchangers	Higher pressure water side construction (150psig)	√		
	Higher pressure water side construction (300psig)		√	
	Flange	√		Exclude counter flange
	Victaulic		√	Exclude coupling
	ASME pressure vessel codes certification		√	
	PED pressure vessel codes certification		√	
Insulations	Compressor acoustic enclosure		√	
	Double thickness insulation		√	
Others	Step-less control		√	
	Soft starter		√	
	Suction service isolation valve	√		
	Single power point connection		√	
	NFB (Non-Fused Breaker) power disconnect switch		√	
	Power factor correction		√	
	Spring isolator		√	
	Flow switch (Pedal type)	√		
	Flow switch (Differential pressure switch)		√	
CE certification		√		

R134a (60Hz)

Model		Units	RCWW008CA1A	RCWW010CA1A	RCWW011CA1A	RCWW012CA1A	RCWW014CA1A	RCWW016CA1A	RCWW018CA1A	RCWW020CA2A
Standard Condition	Cooling capacity	kW	260.94	317.8	359.17	385.85	452.8	542.19	607.69	637.77
		usRT	74.2	90.4	102.1	109.7	128.7	154.2	172.8	181.3
	Input Power	kW	55.67	67.41	75.99	82.56	91.38	113.77	120.42	134.42
	COP		4.7	4.7	4.7	4.7	5	4.8	5	4.7
AHRI Conditions	Cooling capacity	kW	263.88	321.43	363.25	390.27	457.96	548.39	614.64	645.48
		usRT	75	91.4	103.3	111	130.2	155.9	174.8	183.5
	Input Power	kW	53.44	64.7	72.94	79.23	87.72	109.19	115.58	128.99
	COP		4.9	5	5	4.9	5.2	5	5.3	5
	IPLV		5.41	5.42	5.45	5.43	5.8	5.61	5.92	6.39
General Unit Data	Number of Circuits		1	1	1	1	1	1	1	2
	Refrigerant, R-134a	kg	70	80	90	100	120	140	160	80 / 80
	Oil Charge	l	16	16	18	20	20	28	28	16 / 16
Weight	Shipping Weight	kg	2,190	2,360	2,450	2,440	2,730	3,060	3,180	4,140
	Operating Weight	kg	2,330	2,520	2,620	2,620	2,960	3,310	3,460	4,410
Compressors	Compressor type		Semi-hermetic twin screw							
	Quantity	EA	1	1	1	1	1	1	1	2
Condenser	Evaporator type	kW	Shell and Tube							
	Water Volume	kW	29	30	32	32	44	46	50	46
	Max. Water Pressure	MPa	1	1	1	1	1	1	1	1
	Max. Refrigerant Pressure	Mpa	1	1	1	1	1	1	1	1
	Min. Cooling Water Flow Rate	l/s	6.6	7.5	8.5	8.5	10.8	12	13.6	12
	Max. Cooling Water Flow Rate	l/s	26.5	30	34.2	34.2	43.2	48.1	54.4	48.1
	Water Connections	DN	100	100	100	100	125	125	125	125
	Evaporator	Evaporator type	kW	Shell and Tube						
Water Volume		l	42	47	47	48	63	65	67	65
Max. Water Pressure		MPa	1	1	1	1	1	1	1	1
Max. Refrigerant Pressure		Mpa	1	1	1	1	1	1	1	1
Min. Chilled Water Flow Rate		l/s	5.6	7.7	7.7	8.4	10.1	11.2	12.6	11.2
Max. Chilled Water Flow Rate		l/s	22.3	30.7	30.7	33.5	40.5	44.6	50.2	44.6
Water Connections		DN	100	100	100	100	125	125	125	125
Dimension	Length	mm	2,940	2,940	2,940	2,940	2,940	2,940	3,050	3,630
	Width	mm	1,450	1,470	1,470	1,470	1,470	1,480	1,480	1,455
	Height	mm	1,760	1,810	1,810	1,840	1,890	1,945	1,950	1,890

Note:

- 1 usRT = 3,024kcal/hr = 3.517kW, 1mH₂O = 9.8kPa
2. Standard conditions :
 Entering / leaving chilled water temperature is 12 / 7 °C (53.6 / 44.6 °F).
 Entering / leaving cooling water temperature is 32 / 37 °C (89.6 / 98.6 °F).
 Fouling factor of water in evaporator is 0.018 m²·°C/kW (0.00002 h-ft²·°F/Btu)
 Fouling factor of water in condenser is 0.044 m²·°C/kW (0.00005 h-ft²·°F/Btu)
3. AHRI conditions :
 Leaving chilled water temperature is 6.7 °C (44 °F). Water flow is 0.043 L/s per kW (2.4 gpm/ton)
 Entering cooling water temperature is 29.4 °C (85 °F). Water flow is 0.054 L/s per kW (3.0 gpm/ton)
 Fouling factor of water in evaporator is 0.018 m²·°C/kW (0.00002 h-ft²·°F/Btu)
 Fouling factor of water in condenser is 0.044 m²·°C/kW (0.00005 h-ft²·°F/Btu)
4. Due to our policy of innovation some specifications may be changed without prior notification.

R134a (60Hz)

Model		Units	RCWW022CA2A	RCWW024CA2A	RCWW026CA2A	RCWW028CA2A	RCWW032CA2A	RCWW036CA2A	RCWW040CA2A
Standard Condition	Cooling capacity	kW	725.74	782.51	849.21	911.8	1095.26	1217.11	1298.18
		usRT	206.4	222.5	241.5	259.3	311.4	346.1	369.1
	Input Power	kW	151.87	164.01	177.89	182.51	227.03	240.05	261.89
	COP		4.8	4.8	4.8	5	4.8	5.1	5
AHRI Conditions	Cooling capacity	kW	734.53	791.98	859.6	922.88	1,108.64	1,231.96	1,314.09
		usRT	208.9	225.2	244.4	262.4	315.2	350.3	373.6
	Input Power	kW	145.73	157.38	170.67	175.14	217.82	230.33	251.25
	COP		5	5	5	5.3	5.1	5.3	5.2
	IPLV		6.44	6.43	6.47	6.74	6.53	6.85	6.73
General Unit Data	Number of Circuits		2	2	2	2	2	2	2
	Refrigerant, R-134a	kg	95 / 95	100 / 100	110 / 110	115 / 115	145 / 145	160 / 160	175 / 175
	Oil Charge	l	18 / 18	20 / 20	23 / 23	20 / 20	28 / 28	28 / 28	28 / 28
Weight	Shipping Weight	kg	4,460	4,600	4,720	4,770	5,580	5,910	5,930
	Operating Weight	kg	4,780	4,940	5,080	5,150	6,040	6,430	6,480
Compressors	Compressor type		Semi-hermetic twin screw						
	Quantity	EA	2	2	2	2	2	2	2
Condenser	Evaporator type	kW	Shell and Tube						
	Water Volume	kW	59	61	61	65	80	86	86
	Max. Water Pressure	MPa	1	1	1	1	1	1	1
	Max. Refrigerant Pressure	Mpa	1	1	1	1	1	1	1
	Min. Cooling Water Flow Rate	l/s	13.6	14.6	14.6	16.9	19	21.6	21.6
	Max. Cooling Water Flow Rate	l/s	54.4	58.6	58.6	67.7	76	86.5	86.5
	Water Connections	DN	150	150	150	150	200	200	200
Evaporator	Evaporator type		Shell and Tube						
	Water Volume	l	67	83	83	87	92	112	112
	Max. Water Pressure	MPa	1	1	1	1	1	1	1
	Max. Refrigerant Pressure	Mpa	1	1	1	1	1	1	1
	Min. Chilled Water Flow Rate	l/s	12.6	13.8	13.8	15.7	18	20.2	20.2
	Max. Chilled Water Flow Rate	l/s	50.2	55.1	55.1	62.8	71.8	80.9	80.9
	Water Connections	DN	150	150	150	150	200	200	200
Dimension	Length	mm	3,685	3,800	3,900	3,860	4,295	4,380	4,380
	Width	mm	1,455	1,485	1,485	1,485	1,485	1,515	1,515
	Height	mm	1,890	1,995	2,005	1,995	2,055	2,105	2,105

Note:

- 1usRT = 3,024kcal/hr = 3.517kW, 1mH₂O = 9.8kPa
- Standard conditions :
 Entering / leaving chilled water temperature is 12 / 7 °C (53.6 / 44.6 °F).
 Entering / leaving cooling water temperature is 32 / 37 °C (89.6 / 98.6 °F).
 Fouling factor of water in evaporator is 0.018 m²·°C/kW (0.00002 h·ft²·°F/Btu)
 Fouling factor of water in condenser is 0.044 m²·°C/kW (0.00005 h·ft²·°F/Btu)
- AHRI conditions :
 Leaving chilled water temperature is 6.7 °C (44 °F). Water flow is 0.043 L/s per kW (2.4 gpm/ton)
 Entering cooling water temperature is 29.4 °C (85 °F). Water flow is 0.054 L/s per kW (3.0 gpm/ton)
 Fouling factor of water in evaporator is 0.018 m²·°C/kW (0.00002 h·ft²·°F/Btu)
 Fouling factor of water in condenser is 0.044 m²·°C/kW (0.00005 h·ft²·°F/Btu)
4. Due to our policy of innovation some specifications may be changed without prior notification.

R134a (50Hz)

Model		Units	RCWW008CA1A	RCWW010CA1A	RCWW011CA1A	RCWW012CA1A	RCWW014CA1A	RCWW016CA1A	RCWW018CA1A
Standard Condition	Cooling capacity	kW	262.24	323	352.2	392.9	453.9	537.1	625.5
		usRT	74.5	91.8	100.1	111.7	129.1	152.7	177.9
	Input Power	kW	56	68.6	73.8	82.9	94.4	112.5	128.5
	COP		4.7	4.7	4.8	4.7	4.8	4.8	4.9
AHRI Conditions	Cooling capacity	kW	264.8	326.7	356.2	397.4	459.1	543.3	632.7
		usRT	75.3	92.9	101.3	113	130.5	154.5	179.9
	Input Power	kW	53.8	65.8	70.8	79.5	90.6	107.9	123.4
	COP		4.9	5	5	5	5.1	5	5.1
	IPLV		5.39	5.45	5.5	5.52	5.57	5.54	5.68
General Unit Data	Number of Circuits		1	1	1	1	1	1	1
	Refrigerant, R-134a	kg	70	80	90	100	120	140	160
	Oil Charge	l	16	20	23	23	28	28	28
Weight	Shipping Weight	kg	2,320	2,410	2,490	2,530	3,020	3,140	3,220
	Operating Weight	kg	2,460	2,570	2,660	2,710	3,250	3,390	3,500
Compressors	Compressor type		Semi-hermetic twin screw						
	Quantity	EA	1	1	1	1	1	1	1
Condenser	Evaporator type	kW	Shell and Tube						
	Water Volume	kW	29	30	32	32	44	46	50
	Max. Water Pressure	MPa	1	1	1	1	1	1	1
	Max. Refrigerant Pressure	Mpa	1	1	1	1	1	1	1
	Min. Cooling Water Flow Rate	l/s	6.6	7.5	8.5	8.5	10.8	12	13.6
	Max. Cooling Water Flow Rate	l/s	26.5	30	34.2	34.2	43.2	48.1	54.4
	Water Connections	DN	100	100	100	100	125	125	125
	Evaporator	Evaporator type		Shell and Tube					
Water Volume		l	42	47	47	48	63	65	67
Max. Water Pressure		MPa	1	1	1	1	1	1	1
Max. Refrigerant Pressure		Mpa	1	1	1	1	1	1	1
Min. Chilled Water Flow Rate		l/s	5.6	7.7	7.7	8.4	10.1	11.2	12.6
Max. Chilled Water Flow Rate		l/s	22.3	30.7	30.7	33.5	40.5	44.6	50.2
Water Connections		DN	100	100	100	100	125	125	125
Dimension	Length	mm	2,940	2,940	2,940	2,940	2,940	3,050	3,120
	Width	mm	1,470	1,470	1,470	1,470	1,480	1,480	1,480
	Height	mm	1,815	1,850	1,855	1,855	1,890	1,895	1,950

Note:

- 1 usRT = 3,024kcal/hr = 3.517kW, 1mH₂O = 9.8kPa
2. Standard conditions :
 Entering / leaving chilled water temperature is 12 / 7 °C (53.6 / 44.6 °F).
 Entering / leaving cooling water temperature is 32 / 37 °C (89.6 / 98.6 °F).
 Fouling factor of water in evaporator is 0.018 m²·°C/kW (0.00002 h-ft²·°F/Btu)
 Fouling factor of water in condenser is 0.044 m²·°C/kW (0.00005 h-ft²·°F/Btu)
3. AHRI conditions :
 Leaving chilled water temperature is 6.7 °C (44 °F). Water flow is 0.043 L/s per kW (2.4 gpm/ton)
 Entering cooling water temperature is 29.4 °C (85 °F). Water flow is 0.054 L/s per kW (3.0 gpm/ton)
 Fouling factor of water in evaporator is 0.018 m²·°C/kW (0.00002 h-ft²·°F/Btu)
 Fouling factor of water in condenser is 0.044 m²·°C/kW (0.00005 h-ft²·°F/Btu)
4. Due to our policy of innovation some specifications may be changed without prior notification.

R134a (50Hz)

Model		Units	RCWW020CA2A	RCWW022CA2A	RCWW024CA2A	RCWW028CA2A	RCWW032CA2A	RCWW036CA2A
Standard Condition	Cooling capacity	kW	649.05	712.67	798.14	915.42	1086.68	1266.22
		usRT	184.5	202.6	226.9	260.3	309	360
	Input Power	kW	136.44	147.07	164.17	188.09	223.83	255.59
	COP		4.8	4.8	4.9	4.9	4.9	5
AHRI Conditions	Cooling capacity	kW	656.92	721.28	807.83	926.52	1,099.94	1,281.75
		usRT	186.8	205.1	229.7	263.4	312.7	364.4
	Input Power	kW	130.92	141.13	157.52	180.48	214.75	245.22
	COP		5	5.1	5.1	5.1	5.1	5.2
	IPLV		6.42	6.52	6.55	6.56	6.57	6.72
General Unit Data	Number of Circuits		2	2	2	2	2	2
	Refrigerant, R-134a	kg	85 / 85	90 / 90	105 / 105	120 / 120	140 / 140	165 / 165
	Oil Charge	l	20 / 20	23 / 23	23 / 23	28 / 28	28 / 28	28 / 28
Weight	Shipping Weight	kg	4,220	4,520	4,780	5,360	5,710	5,990
	Operating Weight	kg	4,500	4,830	5,130	5,750	6,160	6,520
Compressors	Compressor type		Semi-hermetic twin screw					
	Quantity	EA	2	2	2	2	2	2
Condenser	Evaporator type	kW	Shell and Tube					
	Water Volume	kW	46	59	61	65	80	86
	Max. Water Pressure	MPa	1	1	1	1	1	1
	Max. Refrigerant Pressure	Mpa	1	1	1	1	1	1
	Min. Cooling Water Flow Rate	l/s	12	13.6	14.6	16.9	19	21.6
	Max. Cooling Water Flow Rate	l/s	48.1	54.4	58.6	67.7	76	86.5
	Water Connections	DN	125	150	150	150	200	200
	Evaporator	Evaporator type		Shell and Tube				
Water Volume		l	65	67	83	87	92	112
Max. Water Pressure		MPa	1	1	1	1	1	1
Max. Refrigerant Pressure		Mpa	1	1	1	1	1	1
Min. Chilled Water Flow Rate		l/s	11.2	12.6	13.8	15.7	18	20.2
Max. Chilled Water Flow Rate		l/s	44.6	50.2	55.1	62.8	71.8	80.9
Water Connections		DN	125	150	150	150	200	200
Dimension	Length	mm	3,800	3,900	4,268	4,295	4,380	4,520
	Width	mm	1,455	1,455	1,485	1,485	1,515	1,545
	Height	mm	1,960	1,970	2,005	2,050	2,060	2,075

Note:

- 1usRT = 3,024kcal/hr = 3.517kW, 1mH₂O = 9.8kPa
- Standard conditions :
 Entering / leaving chilled water temperature is 12 / 7 °C (53.6 / 44.6 °F).
 Entering / leaving cooling water temperature is 32 / 37 °C (89.6 / 98.6 °F).
 Fouling factor of water in evaporator is 0.018 m²·°C/kW (0.00002 h·ft²·°F/Btu)
 Fouling factor of water in condenser is 0.044 m²·°C/kW (0.00005 h·ft²·°F/Btu)
- AHRI conditions :
 Leaving chilled water temperature is 6.7 °C (44 °F). Water flow is 0.043 L/s per kW (2.4 gpm/ton)
 Entering cooling water temperature is 29.4 °C (85 °F). Water flow is 0.054 L/s per kW (3.0 gpm/ton)
 Fouling factor of water in evaporator is 0.018 m²·°C/kW (0.00002 h·ft²·°F/Btu)
 Fouling factor of water in condenser is 0.044 m²·°C/kW (0.00005 h·ft²·°F/Btu)
- Due to our policy of innovation some specifications may be changed without prior notification.

RCWW008CA1A

Chilled Water Inlet/Outlet (°C)	Cooling water Inlet/Outlet											
	22 / 27		24 / 29		26 / 31		28 / 33		30 / 35		32 / 37	
	Capa. (kW)	PI (kW)	Capa. (kW)	PI (kW)	Capa. (kW)	PI (kW)	Capa. (kW)	PI (kW)	Capa. (kW)	PI (kW)	Capa. (kW)	PI (kW)
10/5	267.0	46.0	262.3	47.5	257.4	49.2	252.4	51	247.3	53.0	242.1	55.1
12/7	287.6	46.5	282.5	48.1	277.3	49.8	272	51.6	266.5	53.6	260.9	55.7
14/9	309.3	47.0	303.8	48.6	298.3	50.3	292.6	52.2	286.8	54.1	280.9	56.3

RCWW010CA1A

Chilled Water Inlet/Outlet (°C)	Cooling water Inlet/Outlet											
	22 / 27		24 / 29		26 / 31		28 / 33		30 / 35		32 / 37	
	Capa. (kW)	PI (kW)	Capa. (kW)	PI (kW)	Capa. (kW)	PI (kW)	Capa. (kW)	PI (kW)	Capa. (kW)	PI (kW)	Capa. (kW)	PI (kW)
10/5	325.5	55.7	319.6	57.5	313.6	59.6	307.5	61.8	301.2	64.1	294.8	66.7
12/7	350.6	56.3	344.3	58.2	337.9	60.3	331.3	62.5	324.7	64.9	317.8	67.4
14/9	377.2	56.9	370.4	58.8	363.6	60.9	356.6	63.2	349.4	65.6	342.1	68.1

RCWW011CA1A

Chilled Water Inlet/Outlet (°C)	Cooling water Inlet/Outlet											
	22 / 27		24 / 29		26 / 31		28 / 33		30 / 35		32 / 37	
	Capa. (kW)	PI (kW)	Capa. (kW)	PI (kW)	Capa. (kW)	PI (kW)	Capa. (kW)	PI (kW)	Capa. (kW)	PI (kW)	Capa. (kW)	PI (kW)
10/5	367.7	62.8	361.1	64.9	354.4	67.2	347.5	69.6	340.5	72.3	333.3	75.1
12/7	395.9	63.5	388.9	65.6	381.7	67.9	374.4	70.4	366.9	73.1	359.2	76
14/9	425.8	64.2	418.3	66.3	410.6	68.7	402.7	71.2	394.7	73.9	386.6	76.8

RCWW012CA1A

Chilled Water Inlet/Outlet (°C)	Cooling water Inlet/Outlet											
	22 / 27		24 / 29		26 / 31		28 / 33		30 / 35		32 / 37	
	Capa. (kW)	PI (kW)	Capa. (kW)	PI (kW)	Capa. (kW)	PI (kW)	Capa. (kW)	PI (kW)	Capa. (kW)	PI (kW)	Capa. (kW)	PI (kW)
10/5	395.2	68.1	388.1	70.4	380.9	72.9	373.4	75.6	365.9	78.5	358.1	81.6
12/7	425.5	68.9	417.9	71.2	410.2	73.8	402.2	76.5	394.1	79.4	385.8	82.6
14/9	457.6	69.7	449.4	72.1	441.1	74.6	432.7	77.4	424.1	80.3	415.2	83.5

RCWW014CA1A

Chilled Water Inlet/Outlet (°C)	Cooling water Inlet/Outlet											
	22 / 27		24 / 29		26 / 31		28 / 33		30 / 35		32 / 37	
	Capa. (kW)	PI (kW)	Capa. (kW)	PI (kW)	Capa. (kW)	PI (kW)	Capa. (kW)	PI (kW)	Capa. (kW)	PI (kW)	Capa. (kW)	PI (kW)
10/5	463.7	75.5	455.4	78	446.9	80.8	438.1	83.7	429.2	86.9	420.1	90.4
12/7	499.4	76.3	490.5	78.9	481.4	81.7	472.1	84.7	462.5	87.9	452.8	91.4
14/9	537.2	77.2	527.6	79.8	517.8	82.6	507.9	85.6	497.8	88.9	487.4	92.4

- Note:
1. PI - Power Input include compressors and condenser fans
 2. Interpolation between points is permissible. Extrapolation is not permitted.
 3. Due to our policy of innovation, some specification may be changed without prior notification.

RCWW016CA1A

Chilled Water Inlet/Outlet (°C)	Cooling water Inlet/Outlet											
	22 / 27		24 / 29		26 / 31		28 / 33		30 / 35		32 / 37	
	Capa. (kW)	PI (kW)	Capa. (kW)	PI (kW)	Capa. (kW)	PI (kW)	Capa. (kW)	PI (kW)	Capa. (kW)	PI (kW)	Capa. (kW)	PI (kW)
10/5	555.2	93.9	545.3	97.1	535.1	100.5	524.8	104.2	514.1	108.2	503.2	112.5
12/7	597.8	95.0	587.1	98.2	576.3	101.7	565.2	105.4	553.8	109.5	542.2	113.8
14/9	642.7	96.0	631.3	99.3	619.7	102.8	607.9	106.6	595.8	110.7	583.4	115.1

RCWW018CA1A

Chilled Water Inlet/Outlet (°C)	Cooling water Inlet/Outlet											
	22 / 27		24 / 29		26 / 31		28 / 33		30 / 35		32 / 37	
	Capa. (kW)	PI (kW)	Capa. (kW)	PI (kW)	Capa. (kW)	PI (kW)	Capa. (kW)	PI (kW)	Capa. (kW)	PI (kW)	Capa. (kW)	PI (kW)
10/5	622.4	99.4	611.2	102.7	599.8	106.4	588.2	110.3	576.2	114.5	564	119
12/7	670.1	100.5	658.1	103.9	645.9	107.6	633.5	111.6	620.7	115.9	607.7	120.4
14/9	720.5	101.7	707.6	105.1	694.6	108.8	681.3	112.9	667.7	117.2	653.9	121.8

RCWW020CA2A

Chilled Water Inlet/Outlet (°C)	Cooling water Inlet/Outlet											
	22 / 27		24 / 29		26 / 31		28 / 33		30 / 35		32 / 37	
	Capa. (kW)	PI (kW)	Capa. (kW)	PI (kW)	Capa. (kW)	PI (kW)	Capa. (kW)	PI (kW)	Capa. (kW)	PI (kW)	Capa. (kW)	PI (kW)
10/5	653.2	111.0	641.5	114.8	629.5	118.8	617.3	123.2	604.7	127.9	591.9	132.9
12/7	703.2	112.3	690.7	116.1	677.9	120.2	664.8	124.6	651.4	129.3	637.8	134.4
14/9	756.1	113.5	742.7	117.3	729.0	121.5	715.1	126	700.8	130.8	686.3	135.9

RCWW022CA2A

Chilled Water Inlet/Outlet (°C)	Cooling water Inlet/Outlet											
	22 / 27		24 / 29		26 / 31		28 / 33		30 / 35		32 / 37	
	Capa. (kW)	PI (kW)	Capa. (kW)	PI (kW)	Capa. (kW)	PI (kW)	Capa. (kW)	PI (kW)	Capa. (kW)	PI (kW)	Capa. (kW)	PI (kW)
10/5	743.3	125.4	730	129.6	716.4	134.2	702.5	139.2	688.2	144.5	673.6	150.2
12/7	800.2	126.8	786	131.1	771.4	135.8	756.5	140.8	741.3	146.1	725.7	151.9
14/9	860.4	128.2	845.1	132.6	829.5	137.3	813.6	142.3	797.4	147.7	780.9	153.5

RCWW024CA2A

Chilled Water Inlet/Outlet (°C)	Cooling water Inlet/Outlet											
	22 / 27		24 / 29		26 / 31		28 / 33		30 / 35		32 / 37	
	Capa. (kW)	PI (kW)	Capa. (kW)	PI (kW)	Capa. (kW)	PI (kW)	Capa. (kW)	PI (kW)	Capa. (kW)	PI (kW)	Capa. (kW)	PI (kW)
10/5	801.5	135.5	787.1	140	772.4	145.0	757.4	150.3	742.0	156.0	726.2	162.2
12/7	862.9	137.0	847.5	141.6	831.7	146.6	815.7	152	799.3	157.8	782.5	164
14/9	927.8	138.5	911.3	143.2	894.5	148.2	877.4	153.7	859.9	159.5	842	165.8

Note:

1. PI - Power Input include compressors and condenser fans
2. Interpolation between points is permissible. Extrapolation is not permitted.
3. Due to our policy of innovation, some specification may be changed without prior notification.

RCWW026CA2A

Chilled Water Inlet/Outlet (°C)	Cooling water Inlet/Outlet											
	22 / 27		24 / 29		26 / 31		28 / 33		30 / 35		32 / 37	
	Capa. (kW)	PI (kW)	Capa. (kW)	PI (kW)	Capa. (kW)	PI (kW)	Capa. (kW)	PI (kW)	Capa. (kW)	PI (kW)	Capa. (kW)	PI (kW)
10/5	870.0	146.8	854.4	151.7	838.5	157.1	822.2	162.9	805.5	169.2	788.4	175.8
12/7	936.3	148.5	919.6	153.5	902.6	159.0	885.2	164.8	867.4	171.1	849.2	177.9
14/9	1,006.3	150.2	988.4	155.3	970.3	160.8	951.7	166.7	932.8	173.1	913.4	179.9

RCWW028CA2A

Chilled Water Inlet/Outlet (°C)	Cooling water Inlet/Outlet											
	22 / 27		24 / 29		26 / 31		28 / 33		30 / 35		32 / 37	
	Capa. (kW)	PI (kW)	Capa. (kW)	PI (kW)	Capa. (kW)	PI (kW)	Capa. (kW)	PI (kW)	Capa. (kW)	PI (kW)	Capa. (kW)	PI (kW)
10/5	934.2	150.8	917.3	155.8	900.2	161.3	882.6	167.3	864.7	173.6	846.3	180.5
12/7	1,005.7	152.5	987.6	157.6	969.3	163.2	950.5	169.2	931.4	175.6	911.8	182.5
14/9	1,081.2	154.1	1,061.9	159.3	1,042.3	165.0	1,022.3	171	1,001.9	177.6	981.1	184.5

RCWW032CA2A

Chilled Water Inlet/Outlet (°C)	Cooling water Inlet/Outlet											
	22 / 27		24 / 29		26 / 31		28 / 33		30 / 35		32 / 37	
	Capa. (kW)	PI (kW)	Capa. (kW)	PI (kW)	Capa. (kW)	PI (kW)	Capa. (kW)	PI (kW)	Capa. (kW)	PI (kW)	Capa. (kW)	PI (kW)
10/5	1,122.1	187.4	1,102	193.7	1,081.4	200.6	1,060.4	208	1,038.9	215.9	1,016.8	224.4
12/7	1,207.7	189.5	1,186.1	195.9	1,164.1	202.9	1,141.7	210.4	1,118.8	218.4	1,095.3	227
14/9	1,298.1	191.7	1,275	198.2	1,251.5	205.2	1,227.6	212.8	1,203.1	220.9	1,178.2	229.6

RCWW036CA2A

Chilled Water Inlet/Outlet (°C)	Cooling water Inlet/Outlet											
	22 / 27		24 / 29		26 / 31		28 / 33		30 / 35		32 / 37	
	Capa. (kW)	PI (kW)	Capa. (kW)	PI (kW)	Capa. (kW)	PI (kW)	Capa. (kW)	PI (kW)	Capa. (kW)	PI (kW)	Capa. (kW)	PI (kW)
10/5	1,247.1	198.2	1,224.6	204.9	1,201.7	212.1	1,178.3	219.9	1,154.4	228.3	1,129.8	237.3
12/7	1,342.3	200.5	1,318.2	207.2	1,293.7	214.6	1,268.8	222.5	1,243.2	231.0	1,217.1	240
14/9	1,442.8	202.7	1,417.1	209.6	1,390.9	217.0	1,364.3	225	1,337.1	233.6	1,309.3	242.7

RCWW040CA2A

Chilled Water Inlet/Outlet (°C)	Cooling water Inlet/Outlet											
	22 / 27		24 / 29		26 / 31		28 / 33		30 / 35		32 / 37	
	Capa. (kW)	PI (kW)	Capa. (kW)	PI (kW)	Capa. (kW)	PI (kW)	Capa. (kW)	PI (kW)	Capa. (kW)	PI (kW)	Capa. (kW)	PI (kW)
10/5	1,330.1	216.0	1,306.3	223.3	1,281.9	231.3	1,257.1	239.8	1,231.6	249.0	1,205.5	258.8
12/7	1,431.2	218.6	1,405.7	226	1,379.7	234.0	1,353.1	242.7	1,326.0	252.0	1,298.2	261.9
14/9	1,537.9	221.1	1,510.6	228.6	1,482.8	236.7	1,454.5	245.5	1,425.6	254.9	1,396.1	264.9

- Note:
1. PI - Power Input include compressors and condenser fans
 2. Interpolation between points is permissible. Extrapolation is not permitted.
 3. Due to our policy of innovation, some specification may be changed without prior notification.

RCWW008CA1A

Chilled Water Inlet/Outlet (°C)	Cooling water Inlet/Outlet											
	22 / 27		24 / 29		26 / 31		28 / 33		30 / 35		32 / 37	
	Capa. (kW)	PI (kW)	Capa. (kW)	PI (kW)	Capa. (kW)	PI (kW)	Capa. (kW)	PI (kW)	Capa. (kW)	PI (kW)	Capa. (kW)	PI (kW)
10/5	268.4	46.1	263.6	47.7	258.7	49.4	253.7	51.2	248.6	53.1	243.3	55.2
12/7	289.0	46.7	283.9	48.2	278.7	49.9	273.3	51.8	267.8	53.7	262.2	55.9
14/9	310.8	47.2	305.3	48.8	299.8	50.5	294	52.3	288.2	54.3	282.3	56.5

RCWW010CA1A

Chilled Water Inlet/Outlet (°C)	Cooling water Inlet/Outlet											
	22 / 27		24 / 29		26 / 31		28 / 33		30 / 35		32 / 37	
	Capa. (kW)	PI (kW)	Capa. (kW)	PI (kW)	Capa. (kW)	PI (kW)	Capa. (kW)	PI (kW)	Capa. (kW)	PI (kW)	Capa. (kW)	PI (kW)
10/5	331.3	56.5	325.3	58.4	319.2	60.5	313	62.7	306.6	65.1	300.1	67.6
12/7	356.8	57.1	350.4	59.1	343.9	61.2	337.2	63.4	330.4	65.8	323.4	68.4
14/9	383.8	57.8	377	59.7	370.0	61.8	362.9	64.1	355.6	66.6	348.2	69.2

RCWW011CA1A

Chilled Water Inlet/Outlet (°C)	Cooling water Inlet/Outlet											
	22 / 27		24 / 29		26 / 31		28 / 33		30 / 35		32 / 37	
	Capa. (kW)	PI (kW)	Capa. (kW)	PI (kW)	Capa. (kW)	PI (kW)	Capa. (kW)	PI (kW)	Capa. (kW)	PI (kW)	Capa. (kW)	PI (kW)
10/5	361.1	60.8	354.6	62.8	348.0	65.1	341.3	67.5	334.3	70.0	327.3	72.8
12/7	388.8	61.5	381.9	63.5	374.9	65.8	367.6	68.2	360.3	70.8	352.7	73.6
14/9	418.2	62.1	410.8	64.2	403.3	66.5	395.6	69	387.7	71.6	379.7	74.4

RCWW012CA1A

Chilled Water Inlet/Outlet (°C)	Cooling water Inlet/Outlet											
	22 / 27		24 / 29		26 / 31		28 / 33		30 / 35		32 / 37	
	Capa. (kW)	PI (kW)	Capa. (kW)	PI (kW)	Capa. (kW)	PI (kW)	Capa. (kW)	PI (kW)	Capa. (kW)	PI (kW)	Capa. (kW)	PI (kW)
10/5	403.1	68.2	395.8	70.5	388.5	73.0	380.9	75.7	373.1	78.6	365.2	81.7
12/7	434.0	69.0	426.2	71.3	418.3	73.9	410.2	76.6	402.0	79.5	393.5	82.6
14/9	466.6	69.8	458.3	72.1	449.9	74.7	441.2	77.5	432.4	80.4	423.4	83.6

RCWW014CA1A

Chilled Water Inlet/Outlet (°C)	Cooling water Inlet/Outlet											
	22 / 27		24 / 29		26 / 31		28 / 33		30 / 35		32 / 37	
	Capa. (kW)	PI (kW)	Capa. (kW)	PI (kW)	Capa. (kW)	PI (kW)	Capa. (kW)	PI (kW)	Capa. (kW)	PI (kW)	Capa. (kW)	PI (kW)
10/5	465.5	77.8	457.1	80.4	448.6	83.2	439.9	86.3	430.9	89.6	421.8	93.1
12/7	501.3	78.7	492.4	81.3	483.2	84.2	473.9	87.3	464.4	90.6	454.6	94.2
14/9	539.2	79.5	529.6	82.2	519.8	85.1	509.9	88.2	499.7	91.6	489.3	95.2

Note:

1. PI - Power Input include compressors and condenser fans
2. Interpolation between points is permissible. Extrapolation is not permitted.
3. Due to our policy of innovation, some specification may be changed without prior notification.

RCWW016CA1A

Chilled Water Inlet/Outlet (°C)	Cooling water Inlet/Outlet											
	22 / 27		24 / 29		26 / 31		28 / 33		30 / 35		32 / 37	
	Capa. (kW)	PI (kW)	Capa. (kW)	PI (kW)	Capa. (kW)	PI (kW)	Capa. (kW)	PI (kW)	Capa. (kW)	PI (kW)	Capa. (kW)	PI (kW)
10/5	550.9	92.6	541	95.7	530.9	99.1	520.6	102.7	510.1	106.7	499.2	110.9
12/7	593.1	93.6	582.5	96.8	571.8	100.2	560.7	103.9	549.5	107.9	537.9	112.2
14/9	637.7	94.7	626.4	97.9	614.9	101.4	603.1	105.1	591.1	109.1	578.9	113.4

RCWW018CA1A

Chilled Water Inlet/Outlet (°C)	Cooling water Inlet/Outlet											
	22 / 27		24 / 29		26 / 31		28 / 33		30 / 35		32 / 37	
	Capa. (kW)	PI (kW)	Capa. (kW)	PI (kW)	Capa. (kW)	PI (kW)	Capa. (kW)	PI (kW)	Capa. (kW)	PI (kW)	Capa. (kW)	PI (kW)
10/5	641.8	105.7	630.3	109.3	618.5	113.2	606.5	117.4	594.2	121.9	581.5	126.7
12/7	690.9	107.0	678.5	110.6	665.9	114.5	653.1	118.8	640.0	123.3	626.5	128.2
14/9	742.7	108.2	729.5	111.9	716.0	115.8	702.3	120.1	688.3	124.7	674	129.6

RCWW020CA2A

Chilled Water Inlet/Outlet (°C)	Cooling water Inlet/Outlet											
	22 / 27		24 / 29		26 / 31		28 / 33		30 / 35		32 / 37	
	Capa. (kW)	PI (kW)	Capa. (kW)	PI (kW)	Capa. (kW)	PI (kW)	Capa. (kW)	PI (kW)	Capa. (kW)	PI (kW)	Capa. (kW)	PI (kW)
10/5	664.8	112.7	652.8	116.5	640.7	120.6	628.2	125	615.5	129.8	602.4	134.9
12/7	715.7	114.0	702.9	117.8	689.9	122.0	676.6	126.4	663.0	131.3	649.1	136.4
14/9	769.4	115.2	755.7	119.1	741.8	123.3	727.6	127.8	713.2	132.7	698.4	137.9

RCWW022CA2A

Chilled Water Inlet/Outlet (°C)	Cooling water Inlet/Outlet											
	22 / 27		24 / 29		26 / 31		28 / 33		30 / 35		32 / 37	
	Capa. (kW)	PI (kW)	Capa. (kW)	PI (kW)	Capa. (kW)	PI (kW)	Capa. (kW)	PI (kW)	Capa. (kW)	PI (kW)	Capa. (kW)	PI (kW)
10/5	729.9	121.5	716.8	125.6	703.4	130.0	689.8	134.8	675.8	139.9	661.4	145.4
12/7	785.9	122.9	771.8	127	757.5	131.5	742.9	136.3	728.0	141.5	712.7	147.1
14/9	845.0	124.2	830	128.4	814.7	132.9	799.1	137.8	783.2	143.1	766.9	148.7

Note:

1. PI - Power Input include compressors and condenser fans
2. Interpolation between points is permissible. Extrapolation is not permitted.
3. Due to our policy of innovation, some specification may be changed without prior notification.

RCWW024CA2A

Chilled Water Inlet/Outlet (°C)	Cooling water Inlet/Outlet											
	22 / 27		24 / 29		26 / 31		28 / 33		30 / 35		32 / 37	
	Capa. (kW)	PI (kW)	Capa. (kW)	PI (kW)	Capa. (kW)	PI (kW)	Capa. (kW)	PI (kW)	Capa. (kW)	PI (kW)	Capa. (kW)	PI (kW)
10/5	817.6	135.6	802.9	140.1	787.9	145.1	772.6	150.4	756.9	156.2	740.8	162.3
12/7	880.2	137.1	864.4	141.7	848.4	146.7	832	152.1	815.3	158.0	798.1	164.2
14/9	946.3	138.6	929.5	143.3	912.3	148.4	894.8	153.8	877.0	159.7	858.8	166

RCWW028CA2A

Chilled Water Inlet/Outlet (°C)	Cooling water Inlet/Outlet											
	22 / 27		24 / 29		26 / 31		28 / 33		30 / 35		32 / 37	
	Capa. (kW)	PI (kW)	Capa. (kW)	PI (kW)	Capa. (kW)	PI (kW)	Capa. (kW)	PI (kW)	Capa. (kW)	PI (kW)	Capa. (kW)	PI (kW)
10/5	937.7	155.3	920.8	160.6	903.6	166.2	886.1	172.4	868.1	178.9	849.6	186
12/7	1,009.5	157.1	991.4	162.4	973.0	168.1	954.2	174.3	935.1	181.0	915.4	188.1
14/9	1,085.3	158.8	1066	164.2	1,046.3	170.0	1,026.3	176.3	1,005.8	183.0	984.9	190.2

RCWW032CA2A

Chilled Water Inlet/Outlet (°C)	Cooling water Inlet/Outlet											
	22 / 27		24 / 29		26 / 31		28 / 33		30 / 35		32 / 37	
	Capa. (kW)	PI (kW)	Capa. (kW)	PI (kW)	Capa. (kW)	PI (kW)	Capa. (kW)	PI (kW)	Capa. (kW)	PI (kW)	Capa. (kW)	PI (kW)
10/5	1,113.3	184.8	1,093.3	191	1,072.9	197.8	1052	205.1	1,030.7	212.9	1,008.8	221.3
12/7	1,198.2	186.9	1,176.8	193.2	1,155.0	200.0	1,132.7	207.4	1,110.0	215.4	1,086.7	223.8
14/9	1,288.0	189.0	1,265.1	195.4	1,241.8	202.3	1,218	209.8	1,193.8	217.8	1,169	226.4

RCWW036CA2A

Chilled Water Inlet/Outlet (°C)	Cooling water Inlet/Outlet											
	22 / 27		24 / 29		26 / 31		28 / 33		30 / 35		32 / 37	
	Capa. (kW)	PI (kW)	Capa. (kW)	PI (kW)	Capa. (kW)	PI (kW)	Capa. (kW)	PI (kW)	Capa. (kW)	PI (kW)	Capa. (kW)	PI (kW)
10/5	1,297.6	210.9	1,274.3	218	1,250.4	225.8	1,226.1	234.1	1,201.2	243.1	1,175.7	252.6
12/7	1,396.4	213.3	1,371.4	220.6	1,345.9	228.4	1,320	236.8	1,293.4	245.9	1,266.2	255.6
14/9	1,500.6	215.8	1,473.9	223.1	1,446.8	231.0	1,419.1	239.6	1,390.8	248.7	1,361.9	258.5

Note:

1. PI - Power Input include compressors and condenser fans
2. Interpolation between points is permissible. Extrapolation is not permitted.
3. Due to our policy of innovation, some specification may be changed without prior notification.

380V / 60Hz

Model	Voltage	Compressor			Total RLA	Max Current	MCA	MOCP	Recommend Fuse size
		LRA	RLA	Start Current					
RCWW008CA1A	Circuit 1	810	99	270	99	270	131	236	158
RCWW010CA1A	Circuit 1	820	117	273	117	273	155	279	186
RCWW011CA1A	Circuit 1	985	133	328	133	328	175	315	210
RCWW012CA1A	Circuit 1	985	144	328	144	328	189	340	227
RCWW014CA1A	Circuit 1	1,115	159	372	159	372	210	378	252
RCWW016CA1A	Circuit 1	1,750	197	583	197	583	259	466	311
RCWW018CA1A	Circuit 1	1,930	215	643	215	643	284	511	341
RCWW020CA2A	Circuit 1	820	117	273	234	390	279	403	310
	Circuit 2	820	117	273					
RCWW022CA2A	Circuit 1	985	133	328	266	461	315	455	350
	Circuit 2	985	133	328					
RCWW024CA2A	Circuit 1	985	143	328	286	471	340	491	378
	Circuit 2	985	143	328					
RCWW026CA2A	Circuit 1	1,115	155	372	310	527	367	530	408
	Circuit 2	1,115	155	372					
RCWW028CA2A	Circuit 1	1,115	159	372	318	531	378	546	420
	Circuit 2	1,115	159	372					
RCWW032CA2A	Circuit 1	1,750	196	583	392	779	466	673	518
	Circuit 2	1,750	196	583					
RCWW036CA2A	Circuit 1	1,930	215	643	858	511	738	568	470
	Circuit 2	1,930	215	643					
RCWW040CA2A	Circuit 1	2,185	234	728	962	554	800	615	508
	Circuit 2	2,185	234	728					

Note:

1. Standard conditions :

Entering chilled water / Leaving chilled water temperature is 12 / 7°C

Entering cooling water / Leaving cooling water temperature is 32 / 37°C

2. Symbols :

LRA : Locked Rotor Ampere

RLA : Rated Load Ampere

MCA : Minimum Circuit Ampere

MOCP : Maximum OverCurrent Protection

Total RLA : Current when all compressor and fan running

Start Current : Starting current of one compressor

Max current : Start current(Circuit 1) + RLA(Circuit 2)

380V / 50Hz

Model		Voltage	Compressor			Total RLA	Max Current	MCA	MOCP	Recommend Fuse size
			LRA	RLA	Start Current					
RCWW008CA1A	Circuit 1	415	700	98	233	98	233	130	234	156
RCWW010CA1A	Circuit 1		810	120	270	120	270	159	286	191
RCWW011CA1A	Circuit 1		875	129	292	129	292	171	308	206
RCWW012CA1A	Circuit 1		1,220	146	407	146	407	191	344	230
RCWW014CA1A	Circuit 1		1,340	166	447	166	447	219	394	263
RCWW016CA1A	Circuit 1		1,565	198	522	198	522	260	468	312
RCWW018CA1A	Circuit 1		1,990	225	663	225	663	294	529	353
RCWW020CA2A	Circuit 1		810	120	270	240	390	286	413	318
	Circuit 2		810	120	270					
RCWW022CA2A	Circuit 1		875	129	292	258	421	308	445	343
	Circuit 2		875	129	292					
RCWW024CA2A	Circuit 1		1,220	145	407	290	552	344	497	383
	Circuit 2		1,220	145	407					
RCWW028CA2A	Circuit 1		1,340	166	447	332	613	394	569	438
	Circuit 2		1,340	166	447					
RCWW032CA2A	Circuit 1		1,565	198	522	396	720	468	676	520
	Circuit 2		1,565	198	522					
RCWW036CA2A	Circuit 1		1,990	224	663	448	887	529	764	588
	Circuit 2		1,990	224	663					

Note:

1. Standard conditions :

Entering chilled water / Leaving chilled water temperature is 12 / 7°C
 Entering cooling water / Leaving cooling water temperature is 32 / 37°C

2. Symbols :

LRA : Locked Rotor Ampere
 RLA : Rated Load Ampere
 MCA : Minimum Circuit Ampere
 MOCP : Maximum OverCurrent Protection
 Total RLA : Current when all compressor and fan running
 Start Current : Starting current of one compressor
 Max current : Start current(Circuit 1) + RLA(Circuit 2)

400V / 50Hz

Model	Voltage	Compressor			Total RLA	Max Current	MCA	MOCP	Recommend Fuse size	
		LRA	RLA	Start Current						
RCWW008CA1A	Circuit 1	400	665	93	222	93	222	124	223	149
RCWW010CA1A	Circuit 1		770	114	257	114	257	151	272	182
RCWW011CA1A	Circuit 1		831	123	277	123	277	163	293	195
RCWW012CA1A	Circuit 1		1,159	139	386	139	386	181	326	218
RCWW014CA1A	Circuit 1		1,273	158	424	158	424	208	374	249
RCWW016CA1A	Circuit 1		1,487	188	496	188	496	248	446	297
RCWW018CA1A	Circuit 1		1,891	214	630	214	630	279	502	335
RCWW020CA2A	Circuit 1		770	114	257	228	371	272	393	303
	Circuit 2		770	114	257					
RCWW022CA2A	Circuit 1		831	123	277	246	400	293	423	325
	Circuit 2		831	123	277					
RCWW024CA2A	Circuit 1		1,159	138	386	276	524	326	471	363
	Circuit 2		1,159	138	386					
RCWW028CA2A	Circuit 1		1,273	158	424	316	582	374	540	415
	Circuit 2		1,273	158	424					
RCWW032CA2A	Circuit 1		1,487	188	496	376	684	446	644	495
	Circuit 2		1,487	188	496					
RCWW036CA2A	Circuit 1		1,891	213	630	426	843	502	725	558
	Circuit 2	1,891	213	630						

Note:

1. Standard conditions :

Entering chilled water / Leaving chilled water temperature is 12 / 7°C

Entering cooling water / Leaving cooling water temperature is 32 / 37°C

2. Symbols :

LRA : Locked Rotor Ampere

RLA : Rated Load Ampere

MCA : Minimum Circuit Ampere

MOCP : Maximum OverCurrent Protection

Total RLA : Current when all compressor and fan running

Start Current : Starting current of one compressor

Max current : Start current(Circuit 1) + RLA(Circuit 2)

415V / 50Hz

Model		Voltage	Compressor			Total RLA	Max Current	MCA	MOCP	Recommend Fuse size
			LRA	RLA	Start Current					
RCWW008CA1A	Circuit 1	415	641	90	214	90	214	119	214	143
RCWW010CA1A	Circuit 1		742	110	247	110	247	145	261	174
RCWW011CA1A	Circuit 1		801	118	267	118	267	156	281	188
RCWW012CA1A	Circuit 1		1,117	134	372	134	372	175	315	210
RCWW014CA1A	Circuit 1		1,227	152	409	152	409	200	360	240
RCWW016CA1A	Circuit 1		1,433	181	478	181	478	238	428	285
RCWW018CA1A	Circuit 1		1,822	206	607	206	607	269	484	323
RCWW020CA2A	Circuit 1		742	110	247	220	357	261	377	290
	Circuit 2		742	110	247					
RCWW022CA2A	Circuit 1		801	118	267	236	385	281	406	313
	Circuit 2		801	118	267					
RCWW024CA2A	Circuit 1		1,117	133	372	266	505	315	455	350
	Circuit 2		1,117	133	372					
RCWW028CA2A	Circuit 1		1,227	152	409	304	561	360	520	400
	Circuit 2		1,227	152	409					
RCWW032CA2A	Circuit 1		1,433	181	478	362	659	428	618	475
	Circuit 2		1,433	181	478					
RCWW036CA2A	Circuit 1		1,822	205	607	410	812	484	699	538
	Circuit 2		1,822	205	607					

Note:

1. Standard conditions :

Entering chilled water / Leaving chilled water temperature is 12 / 7°C
 Entering cooling water / Leaving cooling water temperature is 32 / 37°C

2. Symbols :

LRA : Locked Rotor Ampere
 RLA : Rated Load Ampere
 MCA : Minimum Circuit Ampere
 MOCP : Maximum OverCurrent Protection
 Total RLA : Current when all compressor and fan running
 Start Current : Starting current of one compressor
 Max current : Start current(Circuit 1) + RLA(Circuit 2)

440V / 60Hz

Model	Voltage	Compressor			Total RLA	Max Current	MCA	MOCP	Recommend Fuse size
		LRA	RLA	Start Current					
RCWW008CA1A	Circuit 1	700	86	233	86	233	114	205	137
RCWW010CA1A	Circuit 1	708	101	236	101	236	134	241	161
RCWW011CA1A	Circuit 1	851	115	284	115	284	151	272	182
RCWW012CA1A	Circuit 1	851	124	284	124	284	163	293	195
RCWW014CA1A	Circuit 1	963	137	321	137	321	181	326	218
RCWW016CA1A	Circuit 1	1,511	170	504	170	504	224	403	269
RCWW018CA1A	Circuit 1	1,667	186	556	186	556	245	441	294
RCWW020CA2A	Circuit 1	708	101	236	202	337	241	348	268
	Circuit 2	708	101	236					
RCWW022CA2A	Circuit 1	851	115	284	230	399	272	393	303
	Circuit 2	851	115	284					
RCWW024CA2A	Circuit 1	851	124	284	248	408	293	423	325
	Circuit 2	851	124	284					
RCWW026CA2A	Circuit 1	963	134	321	268	455	317	458	353
	Circuit 2	963	134	321					
RCWW028CA2A	Circuit 1	963	137	321	274	458	326	471	363
	Circuit 2	963	137	321					
RCWW032CA2A	Circuit 1	1,511	169	504	338	673	403	582	448
	Circuit 2	1,511	169	504					
RCWW036CA2A	Circuit 1	1,667	186	556	372	742	441	637	490
	Circuit 2	1,667	186	556					
RCWW040CA2A	Circuit 1	1,887	202	629	831	477	689	530	488
	Circuit 2	1,887	202	629					

Note:

1. Standard conditions :
 Entering chilled water / Leaving chilled water temperature is 12 / 7°C
 Entering cooling water / Leaving cooling water temperature is 32 / 37°C
2. Symbols :
 LRA : Locked Rotor Ampere
 RLA : Rated Load Ampere
 MCA : Minimum Circuit Ampere
 MOCP : Maximum OverCurrent Protection
 Total RLA : Current when all compressor and fan running
 Start Current : Starting current of one compressor
 Max current : Start current(Circuit 1) + RLA(Circuit 2)

460V / 60Hz

Model		Voltage	Compressor			Total RLA	Max Current	MCA	MOCP	Recommend Fuse size
			LRA	RLA	Start Current					
RCWW008CA1A	Circuit 1	460	669	82	223	82	223	109	196	131
RCWW010CA1A	Circuit 1		677	97	226	97	226	128	230	153
RCWW011CA1A	Circuit 1		814	110	271	110	271	145	261	174
RCWW012CA1A	Circuit 1		814	119	271	119	271	156	281	188
RCWW014CA1A	Circuit 1		921	131	307	131	307	174	313	209
RCWW016CA1A	Circuit 1		1,446	163	482	163	482	214	385	257
RCWW018CA1A	Circuit 1		1,594	178	531	178	531	235	423	282
RCWW020CA2A	Circuit 1		677	97	226	194	323	230	332	255
	Circuit 2		677	97	226					
RCWW022CA2A	Circuit 1		814	110	271	220	381	261	377	290
	Circuit 2		814	110	271					
RCWW024CA2A	Circuit 1		814	118	271	236	389	281	406	313
	Circuit 2		814	118	271					
RCWW026CA2A	Circuit 1		921	128	307	256	435	304	439	338
	Circuit 2		921	128	307					
RCWW028CA2A	Circuit 1		921	131	307	262	438	313	452	348
	Circuit 2		921	131	307					
RCWW032CA2A	Circuit 1		1,446	162	482	324	644	385	556	428
	Circuit 2		1,446	162	482					
RCWW036CA2A	Circuit 1		1,594	178	531	356	709	423	611	470
	Circuit 2	1,594	178	531						
RCWW040CA2A	Circuit 1	1,805	193	602	386	795	457	660	508	
	Circuit 2	1,805	193	602						

Note:

1. Standard conditions :

- Entering chilled water / Leaving chilled water temperature is 12 / 7°C
- Entering cooling water / Leaving cooling water temperature is 32 / 37°C

2. Symbols :

- LRA : Locked Rotor Ampere
- RLA : Rated Load Ampere
- MCA : Minimum Circuit Ampere
- MOCP : Maximum OverCurrent Protection
- Total RLA : Current when all compressor and fan running
- Start Current : Starting current of one compressor
- Max current : Start current(Circuit 1) + RLA(Circuit 2)

480V / 60Hz

Model	Voltage	Compressor			Total RLA	Max Current	MCA	MOCP	Recommend Fuse size
		LRA	RLA	Start Current					
RCWW008CA1A	Circuit 1	641	78	214	78	214	104	187	125
RCWW010CA1A	Circuit 1	649	93	216	93	216	123	221	147
RCWW011CA1A	Circuit 1	780	105	260	105	260	139	250	167
RCWW012CA1A	Circuit 1	780	114	260	114	260	150	270	180
RCWW014CA1A	Circuit 1	883	126	294	126	294	166	299	200
RCWW016CA1A	Circuit 1	1,385	156	462	156	462	205	369	246
RCWW018CA1A	Circuit 1	1,528	170	509	170	509	225	405	270
RCWW020CA2A	Circuit 1	649	93	216	186	309	221	319	245
	Circuit 2	649	93	216					
RCWW022CA2A	Circuit 1	780	105	260	210	365	250	361	278
	Circuit 2	780	105	260					
RCWW024CA2A	Circuit 1	780	113	260	226	373	270	390	300
	Circuit 2	780	113	260					
RCWW026CA2A	Circuit 1	883	123	294	246	417	290	419	323
	Circuit 2	883	123	294					
RCWW028CA2A	Circuit 1	883	126	294	252	420	299	432	333
	Circuit 2	883	126	294					
RCWW032CA2A	Circuit 1	1,385	155	462	310	617	369	533	410
	Circuit 2	1,385	155	462					
RCWW036CA2A	Circuit 1	1,528	170	509	340	679	405	585	450
	Circuit 2	1,528	170	509					
RCWW040CA2A	Circuit 1	1,730	185	577	370	762	439	634	488
	Circuit 2	1,730	185	577					

Note:

1. Standard conditions :

Entering chilled water / Leaving chilled water temperature is 12 / 7°C
 Entering cooling water / Leaving cooling water temperature is 32 / 37°C

2. Symbols :

LRA : Locked Rotor Ampere
 RLA : Rated Load Ampere
 MCA : Minimum Circuit Ampere
 MOCP : Maximum OverCurrent Protection
 Total RLA : Current when all compressor and fan running
 Start Current : Starting current of one compressor
 Max current : Start current(Circuit 1) + RLA(Circuit 2)

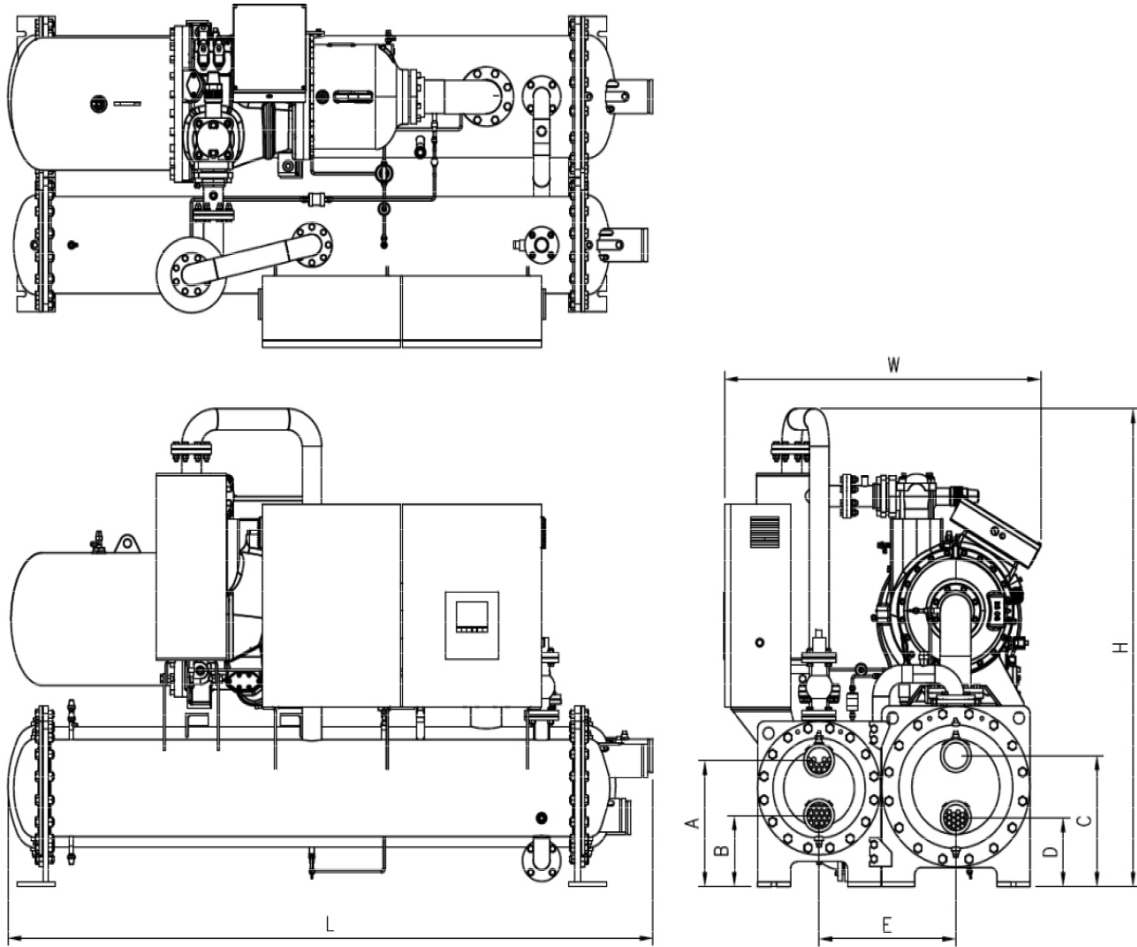

Frequency	Model	L	W	H	A	B	C	D	E
60 Hz	RCWW008CA1A	2,940	1,450	1,760	505	275	530	250	560
	RCWW010CA1A	2,940	1,470	1,810	505	275	530	250	560
	RCWW011CA1A	2,940	1,470	1,810	505	275	530	250	560
	RCWW012CA1A	2,940	1,470	1,840	505	275	530	250	560
	RCWW014CA1A	2,940	1,470	1,890	530	300	555	275	623
	RCWW016CA1A	2,940	1,480	1,945	530	300	555	275	623
	RCWW018CA1A	3,050	1,480	1,950	530	300	555	275	623
50Hz	RCWW008CA1A	2,940	1,470	1,815	505	275	530	250	560
	RCWW010CA1A	2,940	1,470	1,850	505	275	530	250	560
	RCWW011CA1A	2,940	1,470	1,855	505	275	530	250	560
	RCWW012CA1A	2,940	1,470	1,855	505	275	530	250	560
	RCWW014CA1A	2,940	1,480	1,890	530	300	555	275	623
	RCWW016CA1A	3,050	1,480	1,895	530	300	555	275	623
	RCWW018CA1A	3,120	1,480	1,950	530	300	555	275	623

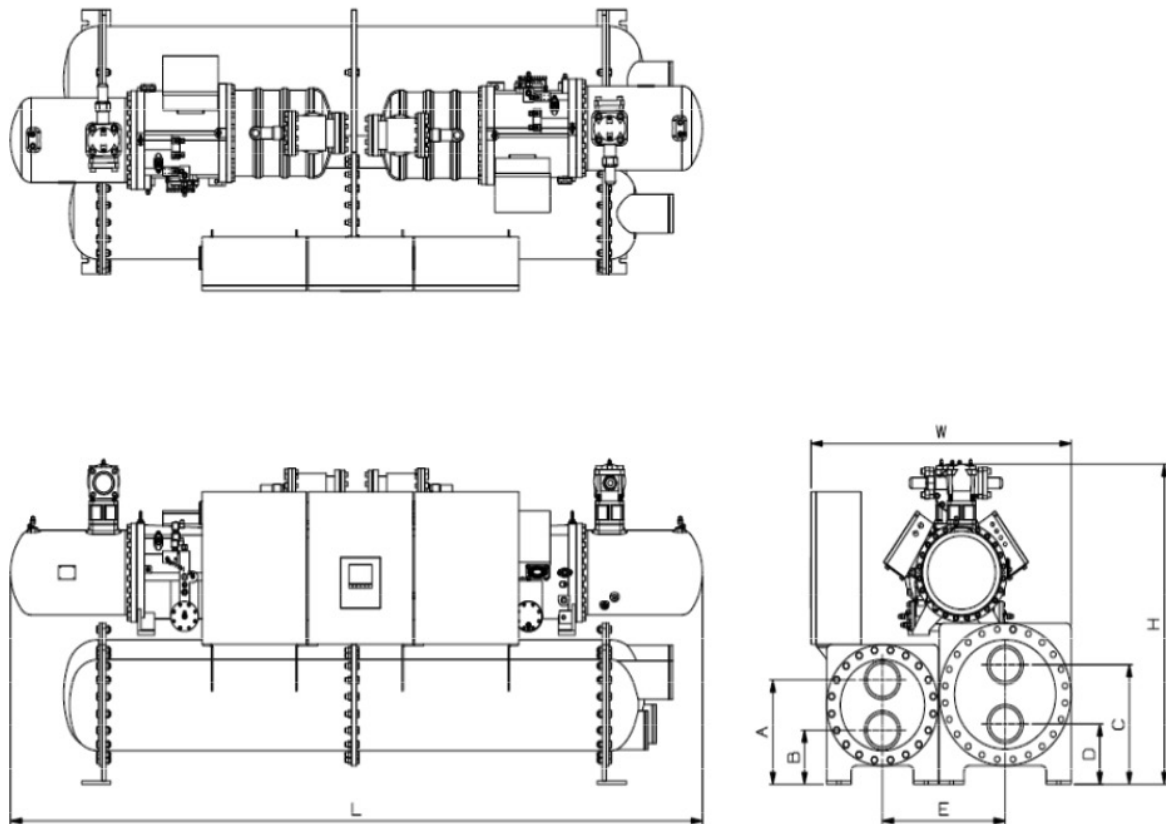

Frequency	Model	L	W	H	A	B	C	D	E
60 Hz	RCWW020CA2A	3,630	1,455	1,890	530	300	555	275	623
	RCWW022CA2A	3,685	1,455	1,890	530	300	555	275	653
	RCWW024CA2A	3,800	1,485	1,995	580	300	600	280	688
	RCWW026CA2A	3,900	1,485	2,005	580	300	600	280	688
	RCWW028CA2A	3,860	1,485	1,995	580	300	600	280	688
	RCWW032CA2A	4,295	1,485	2,055	580	300	600	280	715
	RCWW036CA2A	4,380	1,515	2,105	605	325	625	305	740
50Hz	RCWW040CA2A	4,380	1,515	2,105	605	325	625	305	740
	RCWW020CA2A	3,800	1,455	1,960	530	300	555	275	623
	RCWW022CA2A	3,900	1,455	1,970	530	300	555	275	653
	RCWW024CA2A	4,268	1,485	2,005	580	300	600	280	688
	RCWW028CA2A	4,295	1,485	2,050	580	300	600	280	688
	RCWW032CA2A	4,380	1,515	2,060	580	300	600	280	715
	RCWW036CA2A	4,520	1,545	2,075	605	325	625	305	740

1 Compressor model

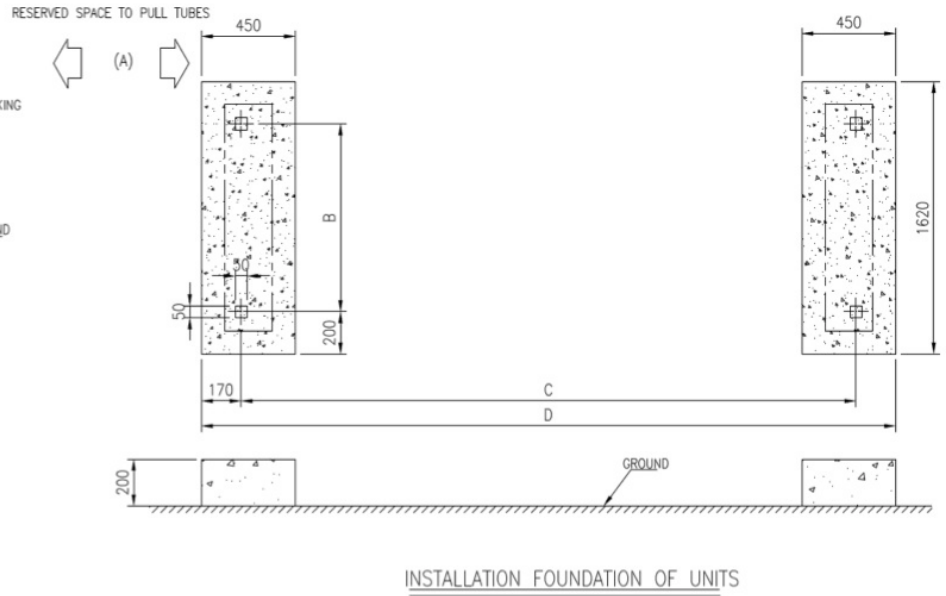
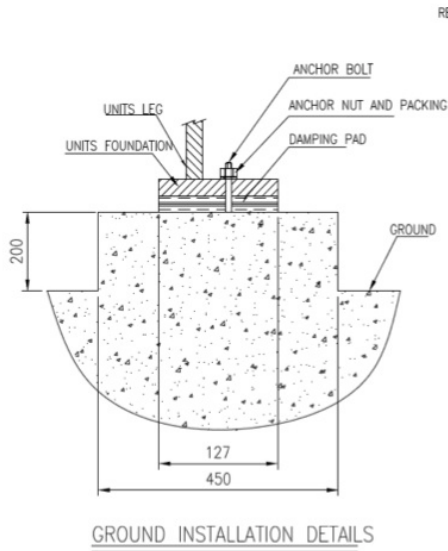

Frequency	Model	A	B	C	D
60 Hz	RCWW008CA1A	2,500	965	2,530	2,870
	RCWW010CA1A	2,500	965	2,530	2,870
	RCWW011CA1A	2,500	965	2,530	2,870
	RCWW012CA1A	2,500	965	2,530	2,870
	RCWW014CA1A	2,500	1,090	2,530	2,870
	RCWW016CA1A	2,500	1,090	2,530	2,870
	RCWW018CA1A	2,500	1,090	2,530	2,870
	RCWW020CA1A	2,500	1,220	2,530	2,870
	RCWW008CA1A	2,500	965	2,530	2,870
	RCWW010CA1A	2,500	965	2,530	2,870
	RCWW011CA1A	2,500	965	2,530	2,870
	RCWW012CA1A	2,500	965	2,530	2,870
	RCWW014CA1A	2,500	1,090	2,530	2,870
	RCWW016CA1A	2,500	1,090	2,530	2,870
	RCWW018CA1A	2,500	1,090	2,530	2,870
	RCWW020CA1A	2,500	1,220	2,530	2,870
50 Hz	RCWW008CA1A	2,500	965	2,530	2,870
	RCWW010CA1A	2,500	965	2,530	2,870
	RCWW011CA1A	2,500	965	2,530	2,870
	RCWW012CA1A	2,500	965	2,530	2,870
	RCWW014CA1A	2,500	1,090	2,530	2,870
	RCWW016CA1A	2,500	1,090	2,530	2,870
	RCWW018CA1A	2,500	1,090	2,530	2,870

2 Compressor model

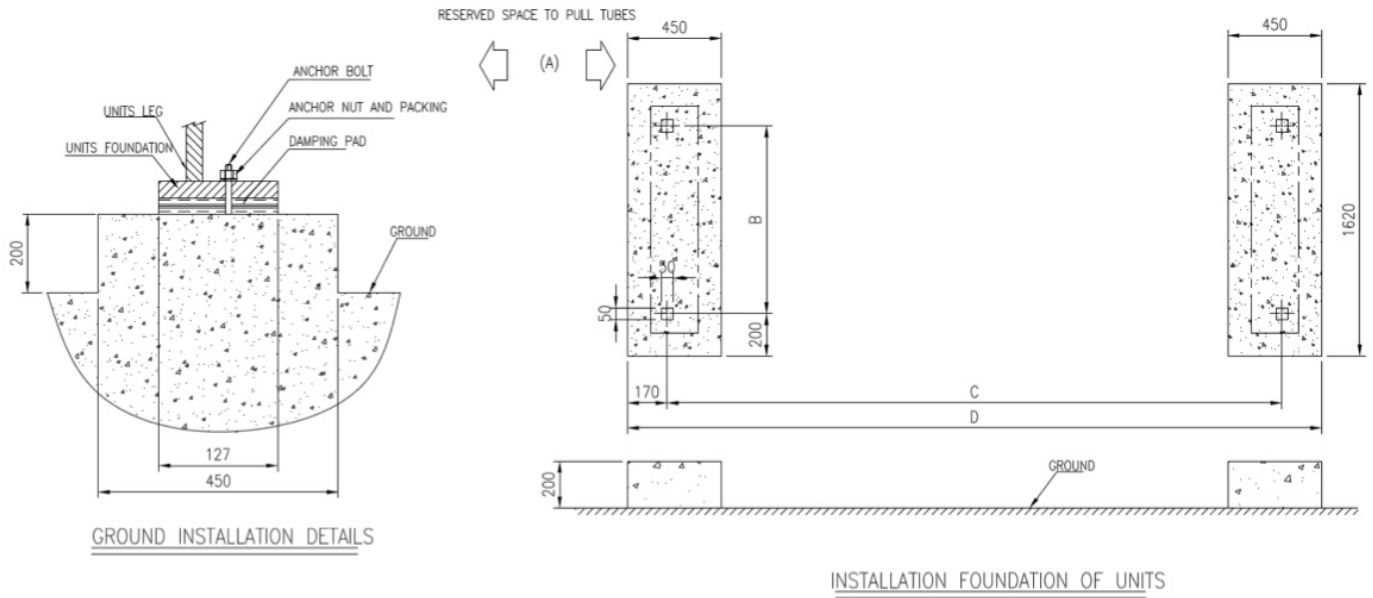

Frequency	Model	A	B	C	D
60 Hz	RCWW020CA2A	3,100	1,090	3,128	3,468
	RCWW022CA2A	3,100	1,090	3,128	3,468
	RCWW024CA2A	3,100	1,220	3,128	3,468
	RCWW026CA2A	3,100	1,220	3,128	3,468
	RCWW028CA2A	3,100	1,220	3,128	3,468
	RCWW032CA2A	3,100	1,220	3,128	3,468
	RCWW036CA2A	3,100	1,325	3,128	3,468
	RCWW040CA2A	3,100	1325	3,128	3,468
	RCWW020CA2A	3,100	1,090	3,128	3,468
	RCWW022CA2A	3,100	1,090	3,128	3,468
	RCWW024CA2A	3,100	1,220	3,128	3,468
	RCWW026CA2A	3,100	1,220	3,128	3,468
	RCWW028CA2A	3,100	1,220	3,128	3,468
	RCWW032CA2A	3,100	1,220	3,128	3,468
	RCWW036CA2A	3,100	1,325	3,128	3,468
	RCWW040CA2A	3,100	1,325	3,128	3,468
50 Hz	RCWW020CA2A	3,100	1,090	3,128	3,468
	RCWW022CA2A	3,100	1,090	3,128	3,468
	RCWW024CA2A	3,100	1,220	3,128	3,468
	RCWW028CA2A	3,100	1,220	3,128	3,468
	RCWW032CA2A	3,100	1,220	3,128	3,468
	RCWW036CA2A	3,100	1,325	3,128	3,468

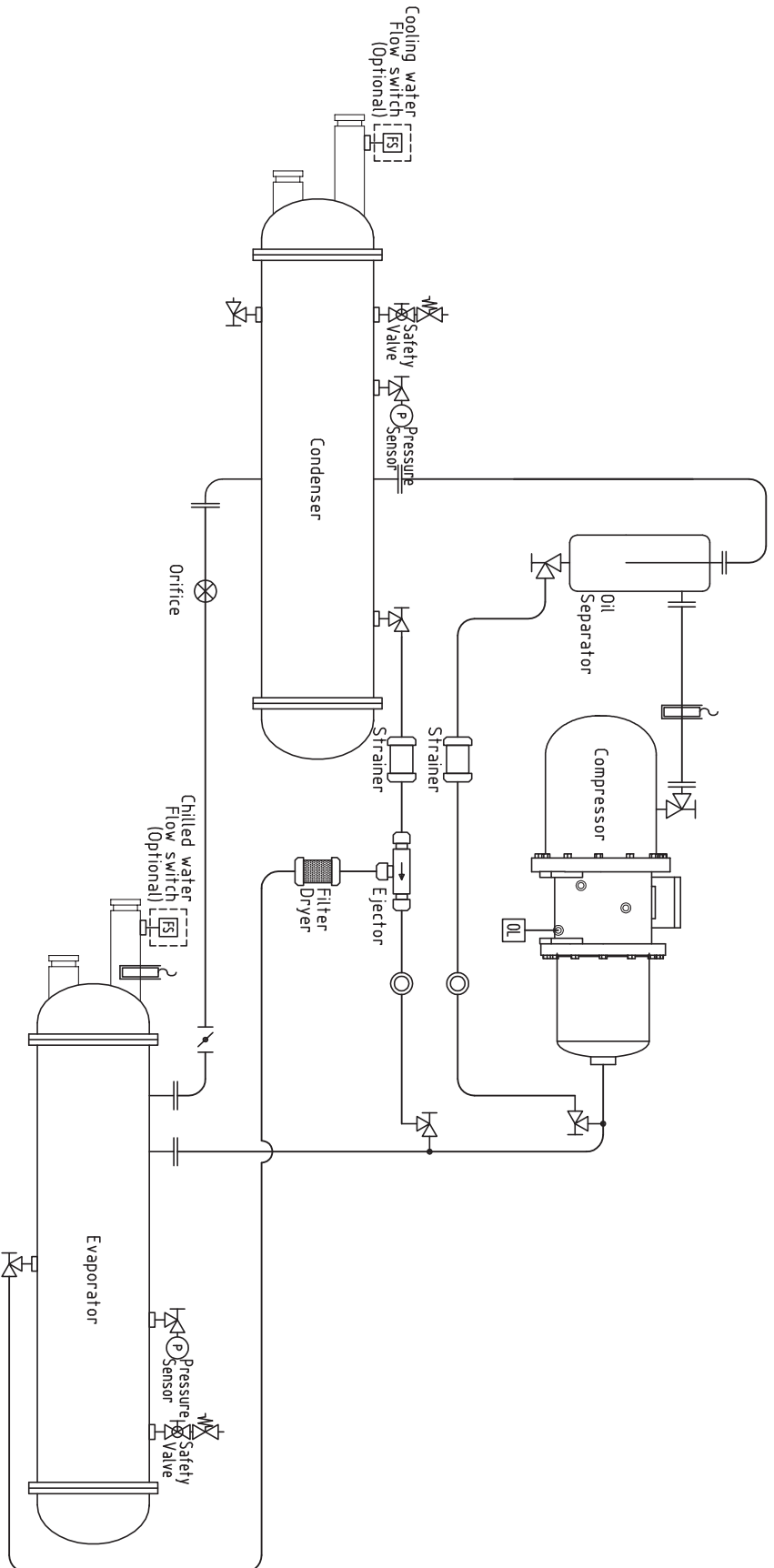

SYMBOL	DESCRIPTION	SYMBOL	DESCRIPTION
	Solenoid valve		High pressure switch
	Electric expansion valve		Low pressure switch
	Expansion device		Differential pressure switch
	Angle valve		Oil level switch
	Ball valve		Flow switch
	Safety valve		Pressure sensor
	Butterfly valve		Temperature sensor
	Check valve		Strainer
	Tee		Filter dryer
	Flange connection		Sight glass
	Reducer		Ejector

Piping diagram

2 Compressor model

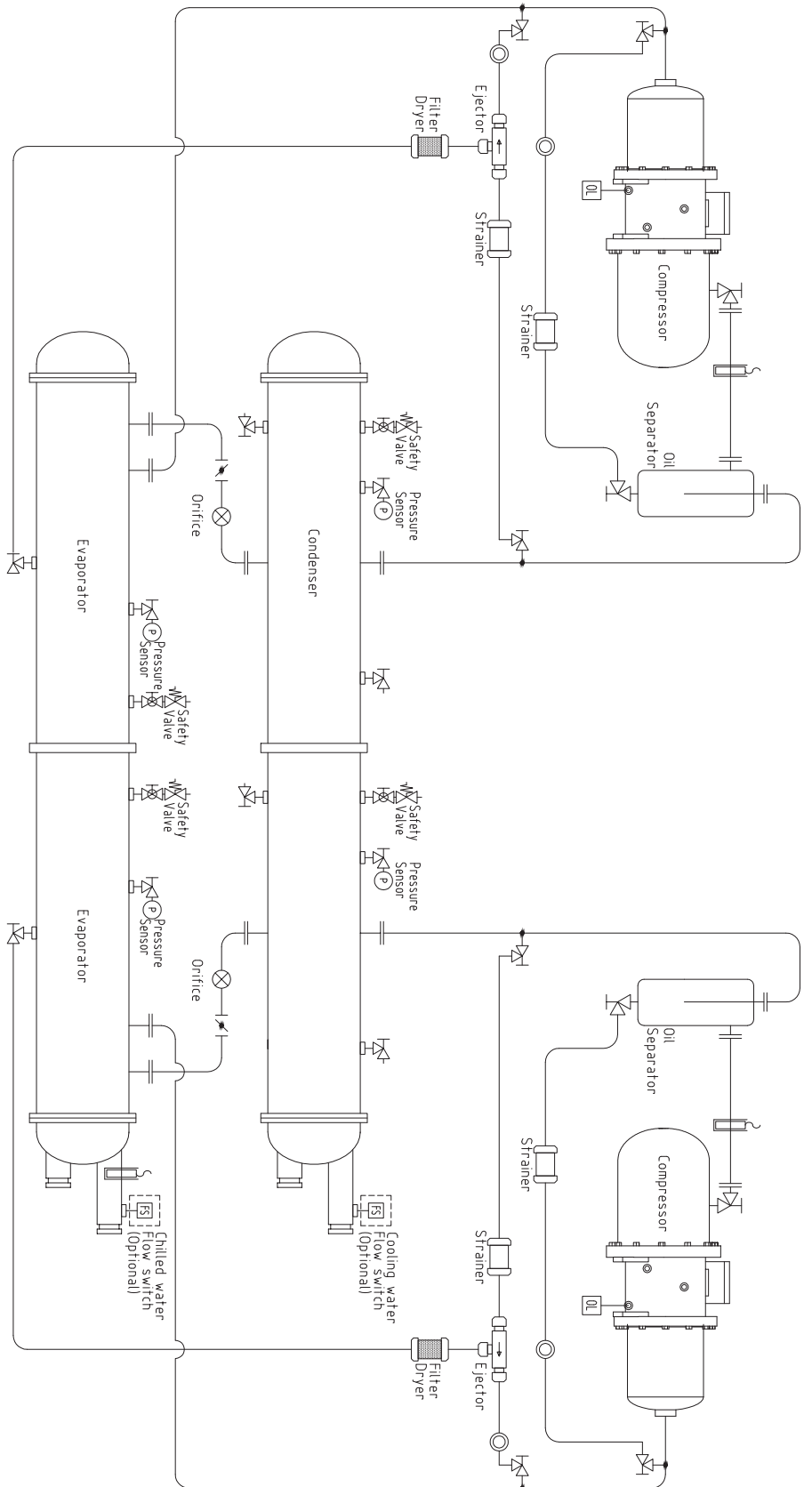

SYMBOL	DESCRIPTION	SYMBOL	DESCRIPTION
	Solenoid valve		High pressure switch
	Electric expansion valve		Low pressure switch
	Expansion device		Differential pressure switch
	Angle valve		Oil level switch
	Ball valve		Flow switch
	Safety valve		Pressure sensor
	Butterfly valve		Temperature sensor
	Check valve		Strainer
	Tee		Filter dryer
	Flange connection		Sight glass
	Reducer		Ejector

Control wiring | 1 Compressor model

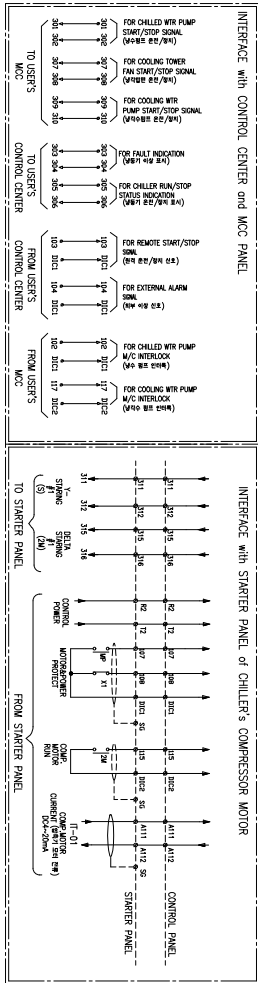

INTERFACE

INTERFACE with CONTROL CENTER and MCC PANEL

INTERFACE with STARTER PANEL of CHILLER'S COMPRESSOR MOTOR

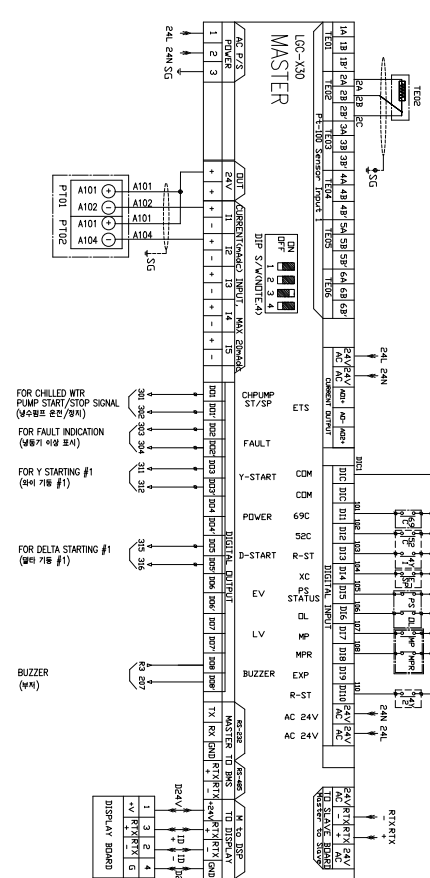
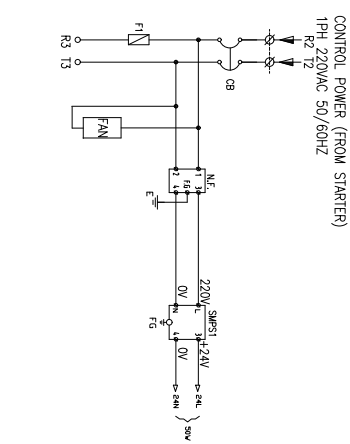
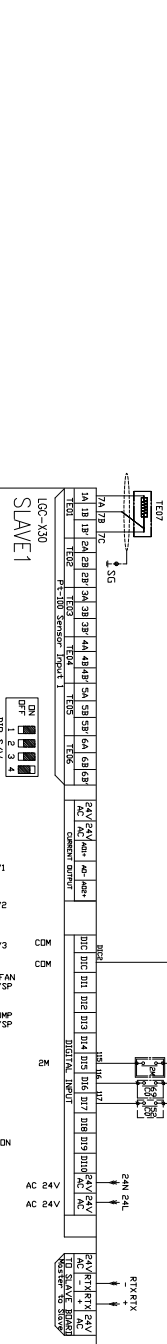
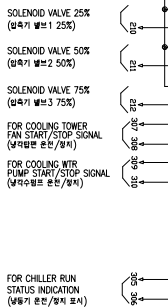
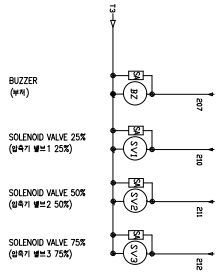

SYMBOL	DESCRIPTION	REMARKS
SG	ALCO CONTACT	SHIPPED BY OREGON-VALLEY WTR PUMP
SG10	ALCO CONTACT	SHIPPED BY OREGON-VALLEY WTR PUMP
SG2	100V 5A	CONTROL RELAY 250V/200V WTR
SG3	100V 5A	CONTROL RELAY 250V/200V WTR
SG4	100V 5A	CONTROL RELAY 250V/200V WTR
SG5	100V 5A	CONTROL RELAY 250V/200V WTR
SG6	100V 5A	CONTROL RELAY 250V/200V WTR
SG7	100V 5A	CONTROL RELAY 250V/200V WTR
SG8	100V 5A	CONTROL RELAY 250V/200V WTR
SG9	100V 5A	CONTROL RELAY 250V/200V WTR
SG10	100V 5A	CONTROL RELAY 250V/200V WTR
SG11	100V 5A	CONTROL RELAY 250V/200V WTR
SG12	100V 5A	CONTROL RELAY 250V/200V WTR
SG13	100V 5A	CONTROL RELAY 250V/200V WTR
SG14	100V 5A	CONTROL RELAY 250V/200V WTR
SG15	100V 5A	CONTROL RELAY 250V/200V WTR
SG16	100V 5A	CONTROL RELAY 250V/200V WTR
SG17	100V 5A	CONTROL RELAY 250V/200V WTR
SG18	100V 5A	CONTROL RELAY 250V/200V WTR
SG19	100V 5A	CONTROL RELAY 250V/200V WTR
SG20	100V 5A	CONTROL RELAY 250V/200V WTR
SG21	100V 5A	CONTROL RELAY 250V/200V WTR
SG22	100V 5A	CONTROL RELAY 250V/200V WTR
SG23	100V 5A	CONTROL RELAY 250V/200V WTR
SG24	100V 5A	CONTROL RELAY 250V/200V WTR
SG25	100V 5A	CONTROL RELAY 250V/200V WTR
SG26	100V 5A	CONTROL RELAY 250V/200V WTR
SG27	100V 5A	CONTROL RELAY 250V/200V WTR
SG28	100V 5A	CONTROL RELAY 250V/200V WTR
SG29	100V 5A	CONTROL RELAY 250V/200V WTR
SG30	100V 5A	CONTROL RELAY 250V/200V WTR
SG31	100V 5A	CONTROL RELAY 250V/200V WTR
SG32	100V 5A	CONTROL RELAY 250V/200V WTR
SG33	100V 5A	CONTROL RELAY 250V/200V WTR
SG34	100V 5A	CONTROL RELAY 250V/200V WTR
SG35	100V 5A	CONTROL RELAY 250V/200V WTR
SG36	100V 5A	CONTROL RELAY 250V/200V WTR
SG37	100V 5A	CONTROL RELAY 250V/200V WTR
SG38	100V 5A	CONTROL RELAY 250V/200V WTR
SG39	100V 5A	CONTROL RELAY 250V/200V WTR
SG40	100V 5A	CONTROL RELAY 250V/200V WTR
SG41	100V 5A	CONTROL RELAY 250V/200V WTR
SG42	100V 5A	CONTROL RELAY 250V/200V WTR
SG43	100V 5A	CONTROL RELAY 250V/200V WTR
SG44	100V 5A	CONTROL RELAY 250V/200V WTR
SG45	100V 5A	CONTROL RELAY 250V/200V WTR
SG46	100V 5A	CONTROL RELAY 250V/200V WTR
SG47	100V 5A	CONTROL RELAY 250V/200V WTR
SG48	100V 5A	CONTROL RELAY 250V/200V WTR
SG49	100V 5A	CONTROL RELAY 250V/200V WTR
SG50	100V 5A	CONTROL RELAY 250V/200V WTR
SG51	100V 5A	CONTROL RELAY 250V/200V WTR
SG52	100V 5A	CONTROL RELAY 250V/200V WTR
SG53	100V 5A	CONTROL RELAY 250V/200V WTR
SG54	100V 5A	CONTROL RELAY 250V/200V WTR
SG55	100V 5A	CONTROL RELAY 250V/200V WTR
SG56	100V 5A	CONTROL RELAY 250V/200V WTR
SG57	100V 5A	CONTROL RELAY 250V/200V WTR
SG58	100V 5A	CONTROL RELAY 250V/200V WTR
SG59	100V 5A	CONTROL RELAY 250V/200V WTR
SG60	100V 5A	CONTROL RELAY 250V/200V WTR
SG61	100V 5A	CONTROL RELAY 250V/200V WTR
SG62	100V 5A	CONTROL RELAY 250V/200V WTR
SG63	100V 5A	CONTROL RELAY 250V/200V WTR
SG64	100V 5A	CONTROL RELAY 250V/200V WTR
SG65	100V 5A	CONTROL RELAY 250V/200V WTR
SG66	100V 5A	CONTROL RELAY 250V/200V WTR
SG67	100V 5A	CONTROL RELAY 250V/200V WTR
SG68	100V 5A	CONTROL RELAY 250V/200V WTR
SG69	100V 5A	CONTROL RELAY 250V/200V WTR
SG70	100V 5A	CONTROL RELAY 250V/200V WTR
SG71	100V 5A	CONTROL RELAY 250V/200V WTR
SG72	100V 5A	CONTROL RELAY 250V/200V WTR
SG73	100V 5A	CONTROL RELAY 250V/200V WTR
SG74	100V 5A	CONTROL RELAY 250V/200V WTR
SG75	100V 5A	CONTROL RELAY 250V/200V WTR
SG76	100V 5A	CONTROL RELAY 250V/200V WTR
SG77	100V 5A	CONTROL RELAY 250V/200V WTR
SG78	100V 5A	CONTROL RELAY 250V/200V WTR
SG79	100V 5A	CONTROL RELAY 250V/200V WTR
SG80	100V 5A	CONTROL RELAY 250V/200V WTR
SG81	100V 5A	CONTROL RELAY 250V/200V WTR
SG82	100V 5A	CONTROL RELAY 250V/200V WTR
SG83	100V 5A	CONTROL RELAY 250V/200V WTR
SG84	100V 5A	CONTROL RELAY 250V/200V WTR
SG85	100V 5A	CONTROL RELAY 250V/200V WTR
SG86	100V 5A	CONTROL RELAY 250V/200V WTR
SG87	100V 5A	CONTROL RELAY 250V/200V WTR
SG88	100V 5A	CONTROL RELAY 250V/200V WTR
SG89	100V 5A	CONTROL RELAY 250V/200V WTR
SG90	100V 5A	CONTROL RELAY 250V/200V WTR
SG91	100V 5A	CONTROL RELAY 250V/200V WTR
SG92	100V 5A	CONTROL RELAY 250V/200V WTR
SG93	100V 5A	CONTROL RELAY 250V/200V WTR
SG94	100V 5A	CONTROL RELAY 250V/200V WTR
SG95	100V 5A	CONTROL RELAY 250V/200V WTR
SG96	100V 5A	CONTROL RELAY 250V/200V WTR
SG97	100V 5A	CONTROL RELAY 250V/200V WTR
SG98	100V 5A	CONTROL RELAY 250V/200V WTR
SG99	100V 5A	CONTROL RELAY 250V/200V WTR
SG100	100V 5A	CONTROL RELAY 250V/200V WTR

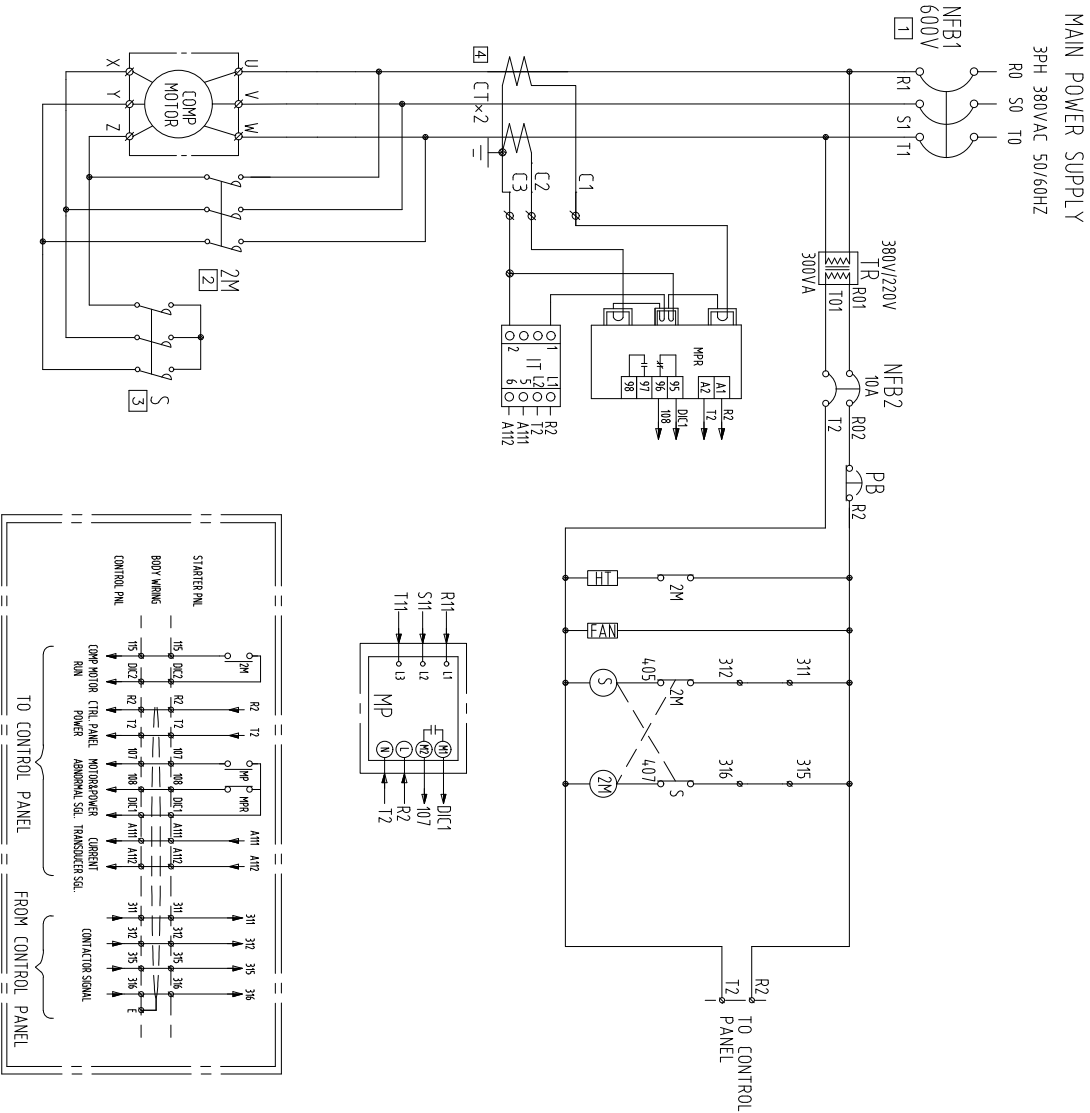

NO.	DESCRIPTION	QTY	REMARKS
1	ZMS		MAGNETIC CONTACTOR
2	NFB1		MOLDED CASED CIRCUIT BREAKER
3	NFB2		NO FUSE BREAKER
4	TR		TRANSFORMER
5	PB		EMERGENCY STOP SWITCH
6	MP		MOTOR PROTECT RELAY
7	MPR		ELECTRONIC MOTOR PROTECTOR RELAY
8	IT		AMPERE TRANSDUCER
9	CT		CURRENT TRANSFORMER
10	FAN		COOLING FAN
11	HT		OIL HEATER

COMPRESSOR MODEL	CONDENSER MODEL	EVAPORATOR MODEL	REFRIGERANT
500/5A	225A	225A	500A
	225A	225A	290RT
	225A	400A	260RT
	225A	400A	220RT
400/5A	185A	185A	350A
	185A	185A	200RT
	185A	350A	180RT
	185A	350A	150RT
300/5A	150A	150A	300A
	150A	150A	120RT
	130A	130A	225A
	130A	130A	100RT
250/5A	100A	100A	200A
	100A	100A	80RT
	85A	85A	150A
	85A	125A	70RT
150/5A	65A	65A	125A
	65A	350A	500RT
400/5A	185A	185A	350A
	185A	185A	200RT
	185A	350A	180RT
	185A	350A	160RT
300/5A	150A	150A	300A
	150A	150A	140RT
	130A	130A	225A
	130A	130A	120RT
250/5A	130A	130A	200A
	100A	100A	110RT
	100A	100A	100RT
200/5A	100A	100A	200A
	100A	100A	80RT
CT	S	Z	NFB1
			ITEM
			NUMBER

Power wiring | 2 Compressor model

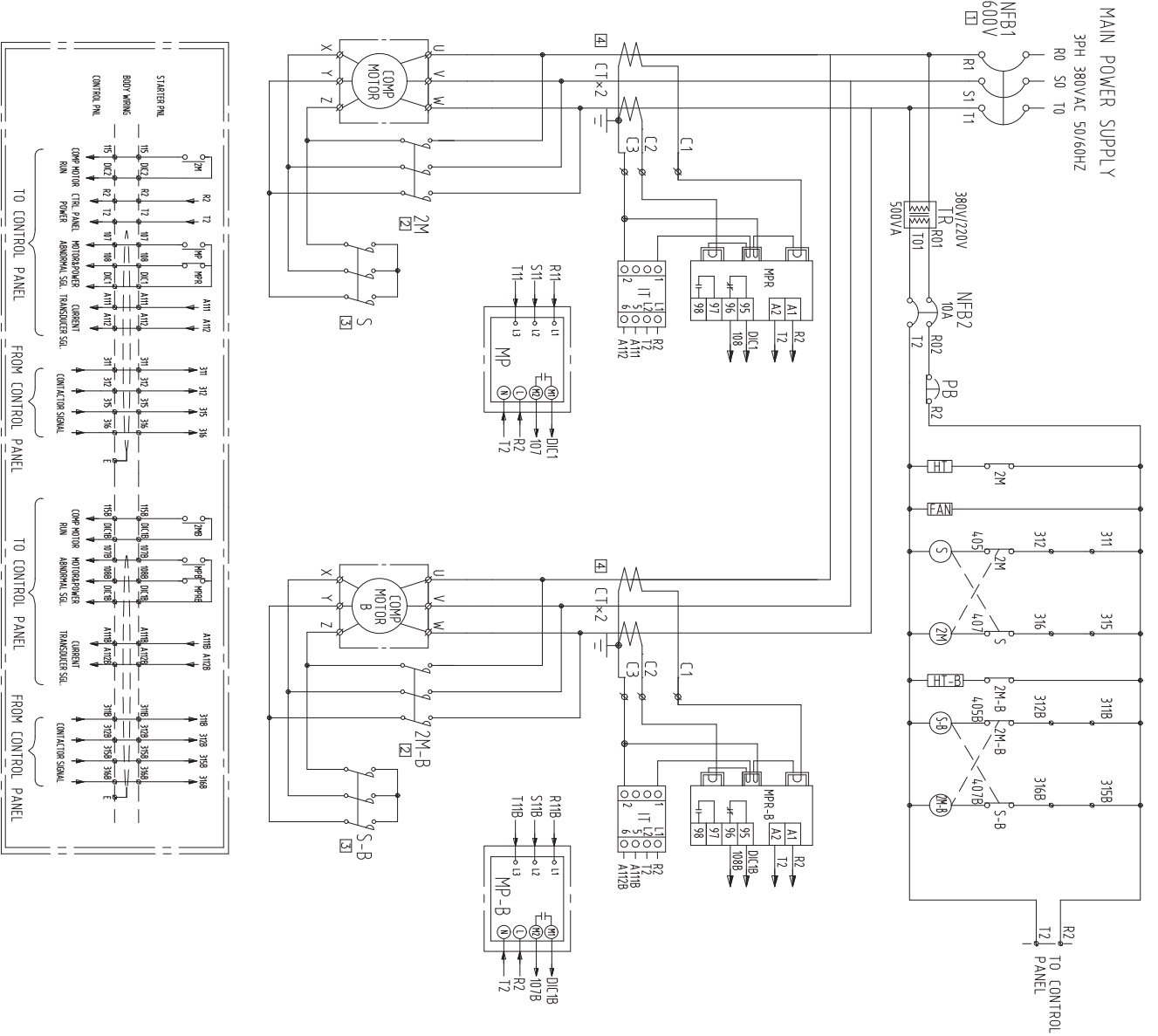

ELECTRICAL PART LIST

1	1M-2M-SS	MAGNETIC CONTACTOR	
2	1M-6-2M-B	MAGNETIC CONTACTOR	
3	S-B	MOULDED CASED CIRCUIT BREAKER	
4	NFB1	NO FUSE BREAKER	
5	NFB2	NO FUSE BREAKER	500VA
6	TR	TRANSFORMER	
7	MP	EMERGENCY STOP SWITCH	
8	MP-B	MOTOR PROTECT RELAY	
9	MPR	ELECTRONIC MOTOR PROTECTOR RELAY	ECOR-SS
10	MPR-B	ELECTRONIC MOTOR PROTECTOR RELAY	ECOR-SS
11	IT	AMPERE TRANSDUCE	
12	IT-B	AMPERE TRANSDUCE	
13	CT-B	CURRENT TRANSFORMER	
14	CT-B	CURRENT TRANSFORMER	
15	FAN	COOLING FAN	
16	KM1-3	AUXILIARY CONTACT	FROM CONTROL PNL
17	KM1B-3B	AUXILIARY CONTACT	FROM CONTROL PNL
18	HT	OIL HEATER	
19	HT-B	OIL HEATER	
20	X1-X2	AUXILIARY RELAY	

500/5A	225A	225A	1000A	520RT	
	225A	225A	800A	450RT	
400/5A	225A	225A	800A	440RT	R22
	185A	185A	700A	400RT	
	185A	185A	600A	350RT	
300/5A	150A	150A	600A	300RT	
	185A	185A	700A	390RT	
400/5A	185A	185A	600A	370RT	
	150A	150A	600A	320RT	
300/5A	150A	150A	600A	320RT	
	130A	130A	500A	280RT	
250/5A	130A	130A	400A	240RT	
	130A	130A	400A	220RT	
200/5A	100A	100A	350A	200RT	
CT	S	ZM	NFB1	ITEM	REFRIGERANT
				NUMBER	

Guide specification

Contents

Part 1 – General

- 1.01 Scope
- 1.02 System descriptions
- 1.03 Quality assurance
- 1.04 Delivery and handling

Part 2 – Products

- 2.01 General
- 2.02 Equipment description
- 2.03 Operating characteristics
- 2.04 Compressor
- 2.05 Heat exchanger
- 2.06 Expansion unit
- 2.07 Controller
- 2.08 Characteristics of the controller
- 2.09 Automatic safety device
- 2.10 Accessories and options

Part 3 - Execution

- 3.01 Installation

Part 1 – General

1.01 Scope

The requirements of the General Conditions, Supplementary Conditions and Drawings apply to all work herein.

1.02 System descriptions

Microprocessor controlled water-cooled liquid chiller utilizing screw compressor(s) and electronic expansion valves.

1.03 Quality assurance

- AHRI 550/590 - water chilling packages using the vapor compression cycle.
- ANSI/ASHRAE 34 - number designation and safety classification of refrigerants.
- ASME Section VIII - boiler and pressure vessel.
- GB/T 18430.1 - water chilling (heat pump) packages using the vapor compression cycle - part 1: water chilling (heat pump) packages for industrial & commercial and similar applications.
- GB25131 - Safety requirements for water chillers (heat pump) using the vapor compression cycle.
- GB150/151 - steel pressure vessels / Tubular heat exchangers.
- ANSI/ASHRAE Standard 15 safety code.
- Manufactured in an EN ISO 9001 accredited organization.

- The packaged chiller shall be pressure and leak test.
- Chiller manufacturer shall have factory trained and supported service organization local to the chiller installation to provide commissioning and service support throughout the manufacturer's warranty period.
- Manufacturer shall warrant all equipment and material of its supply against defects in workmanship and material for a period of eighteen (18) months from date of shipment or twelve(12) months from initial start-up, whichever occurs first.

1.04 Delivery and handling

Depending on the condition of the installation site, chiller is shipped as a single unit or as separated unit, and as charged with refrigerant or with nitrogen. If shipped as separated units, contact the authorized LG Electronics dealers or LG Electronics directly. For single unit type, the unit will be delivered to the site as preassembled. Separated unit type will be delivered as 2 or 3 separated main pieces. Confirm and record that it is the correct unit and that it is properly equipped as the submitted packing list. When refrigerant is charged, refrigerant and oil are charged together according to the specification of the chiller unit. It needs special attention to high pressure inside since the saturated refrigerant pressure is decided by the external air temperature. When nitrogen is charged, the unit is charged with 0.5kg/cm² before shipment from the factory. If the pressure is "0", please record the condition and check for any leakage, since there is leak possibility.

Unit shall be handled, transported and stored in accordance with manufacturer's instructions.

Shipping: Unit shall ship in one piece and shall require installer to provide the evaporator and condenser inlet and outlet pipe connections. If providing chiller model that ships in multiple pieces, bid shall include all the material and field labor costs for factory authorized personnel to connect the pieces as well as all interconnecting piping and wiring.

Part 2 – Products

2.01 General

The equipment shown on the drawings is based on the model RCWW and MCWW series water cooled liquid chiller as manufactured by the LG Electronics.

2.02 Equipment description

Supply and install and commission as shown on the drawings and schedules complete factory assembled, charged and operationally tested air cooled screw compressor chiller(s) as specified herein. Chiller shall include one or more independent refrigeration circuits, semi hermetic twin screw compressors(s), shell and tube liquid cooler & condenser, Refrigerant R-134a, lubrication system and oil, interconnecting piping and wiring and lockable control center housing safety, operating and capacity controls necessary for the safe automatic operation of the liquid chiller.

2.03 Operating characteristics

- Chiller will be installed in an indoor location and shall be capable of operating in room temperatures between 4.4°C and 15.6°C (40F~60F)
- Provide capacity control system capable of reducing unit capacity to min. 25% of full load.

2.04 Compressor

The semi-hermetic twin screw compressor with precision machined cast iron housing and discharge shutoff valve. Compressor motor is cooled down by refrigerants. The differential pressure type oil lubrication and a filter-integrated type should be used. A compressor integrated type oil separator is used, a check valve should be installed at the discharge side to prevent the backward flowing of the refrigerants. Design working pressure of entire compressor, suction to discharge shall be 30 bar (435 psig) 4-step or stepless control that can control the capacity from 25 % to 100 % using a capacity control slide valve. A discharge/suction shut-off valve is installed.

To separate the oil from the refrigerant in which oil is mixed together, the internal oil separator is designed to allow the oil flow into the system to the minimum.

2.05 Heat exchanger

| Falling Film Type |

Evaporator shall be of the falling film shell and tube type with removable heads and mechanically cleanable tubes of seamless copper with internally and externally enhanced surface. Distributer located on the top side of inside shell, this makes uniform flow of refrigerant. Through distributor refrigerant flows downward by gravity as a continuous film. Tubes shall be mechanically expanded into multiple grooves in tube sheets. Cooler will incorporate one, two independent refrigerant circuits with a common chilled liquid multi-pass circuit arrangement. Coolers will be factory insulated with 19mm (optional 38) closed cell insulation with all joints vapor sealed and water drain and vent taps in cooler heads.

| Condenser |

The shall is manufactured Shell & Tube and shell be constructed and tested in accordance with pressure vessel code for a refrigerant and 10bar(150 psig) water-side pressure. To increase efficiency, sub-cooler is installed for over-cooling of condenser liquid refrigerant.

2.06 Expansion unit

Expansion unit consists of butterfly valve and orifice. At 100% load situation, the pressure loss at the orifice is smaller than the refrigerant pressure loss in the condenser, thus the super-cooled refrigerant passes through the orifice. At this stage the maximum amount of refrigerant is flowing into the evaporator. As the load reduces gradually, the circulating amount of refrigerant also reduces and accordingly the refrigerant level in the condenser is getting low. When the amount of liquid refrigerant reduces, the gas amount in the orifice is getting larger, raising the resistance thus controlling the flow rate.

| Refrigerant isolation v/v: Option |

Refrigerant isolation valves shall be provided to isolate the referent into the condenser for standard water chilling application.

2.07 Controller

| Composition of the control panel |

The control panel is composed of a Micom module (a main module, an I/O module, a display and an operation key module), a power supply unit that provides stable power, and a breaker that performs other control jobs or ensures safety, magnetic contact, and a relay for control. The major functions of these modules are as follows.

| Main module |

A high-performance microprocessor is installed in the main module and performs the control function optimized to equipment. A high-precision analog/digital converter measures sensor values in real time and displays them on the

screen or applies them for the equipment control. In addition, the RS-485/232C communication port is integrated to support customers' remote monitoring. Customers can select RS-485 or RS-232C with simple operation. Therefore, It can be responded to the building automation easily.

| Display and operation key module |

The display and operation key module is composed of setting values needed for various operation data and equipment operation, a display unit that displays the malfunction information in texts, a key input unit that enables operators to input data or select menus, and a LED lamp display unit. In particular, the convenience for operators is enhanced by allowing them to use keys directly, if keys are used frequently, or select menus. Operation keys are composed of four menu handling keys, three manual control value handling keys, three manual extraction pump handling keys and two run/stop keys to run or stop the equipment operation. If the operation keys are out of order, operators can handle the control valve and the refrigerant value using the text display unit and the menu selection key. In addition, the operation status (temperature, running/stopping of the neighboring device, storage) can be displayed in English, Chinese or Korean for users' convenience.

| I/O module |

The I/O module is composed of a digital input unit which checks the operational state of various switches, and a digital output unit that controls the equipment operation. In addition, a photo coupler is installed at the I/O unit to block noises. All the I/O module data can be sent and received from the main module. Therefore, the malfunction by the EMI, which can occur when the data are transmitted using a regular cable, can be prevented and high availability can be secured.

2.08 Characteristics of the controller

| Convenient management of the operation data |

The 7.1 inch color LCD shows much operation information on a screen. The analog data (e.g., temperature data) can be saved for 300 times by intervals defined by customers. The data can be used to keep operation logs or to perform maintenance work. In addition, the temperature of the chilled water outlet is displayed on a graph so that customers can understand the trend of temperature changes conveniently.

| Safety controller algorithm |

The safety parts such as high and low pressure sensor, discharge temperature, current sensor can help product operation without shutdown. This algorithm can be minimized malfunction operations without manual reset.

| Self-diagnosis and malfunction history saving |

The microcomputer monitors the equipment state when the equipment is stopped or running, and informs the state

to operators using text messages, alarm lamps and buzzers. The advice function shows cause of malfunction and checking point and troubleshooting. It can be saved in USB memory with operation and malfunction history.

| Optimized artificial intelligent control algorithm |

- Flexible Startup

To prevent excessive shocks to the equipment due to any abrupt load at the time of startup, the input power will be supplied gradually.

| Advanced digital PID control |

A digital PID control together with its smooth start-up minimizes unnecessary chiller shut-downs by recognizing the optimal PID control point automatically when the chiller is started or the chiller operation mode is changed from manual to automatic, and applying the point to the control formula. Compared with existing analog controls, more stable and accurate temperature control is possible.

- ※ A digital transmitter to show and monitor the evaporator pressure/condenser pressure/ differential oil pressure.
- ※ A digital transmitter to show and monitor the current/voltage.
- ※ PT 100 sensor a chilled water/Cooling water/Oil temperature PT 100 Sensor installation.

| Scheduled operation function |

Customers can conveniently run the equipment using the schedule operation function that allows customers to select Run/Stop and control temperature setting values by weekday or holiday for 11 times per day.

| Customer support function |

- Communication function for building automation, remote surveillance and control The communication function (RS232C/RS485, users can select) is integrated so that the equipment can be connected to customers' monitoring system with ease. Also, no voltage I/O is provided so that customers can run/stop the equipment or remotely monitor the important operation state using a simple electric wiring. MODBUS is basic specification, BACnet and Modem is optional.

- Help function

If a malfunction occurs, the details thereabout will be logged and operators can take measures using the help function.

- Three language support

Users can select Korean, Chinese or English languages from the operation menu.

- Pump down function

If the operation stops, the pump-down operation will be started automatically and the refrigerants will be gathered at the condenser. Therefore, the equipment can be operated cost-effectively by its improved operation stability and by preventing the liquid suction during the operation.

2.09 Automatic safety device

A double protection device that prevents reverse phase, phase loss and overcurrents is installed. Therefore, the compressor can be completely protected against external electric shocks.

Chilled water and cooling water safety device

- A chilled water pump interlock contact
- A cooling water pump interlock contact
- A chilled /cooling water flow switch: chilled /cooling water level – under 50 %.
- Chilled water temperature (low): Chilled water out temperature – under 2.5°C.
- Evaporator refrigerant temperature (low) – Refrigerant temperature – under 2.5°C.
- ※ A run/stop signal and interlock contact of the chilled water and cooling water pump is a very important safety device that can prevent freezing and bursting and safety incidents. Therefore, make sure to connect the line in such a way that the chiller, the chilled water pump and the cooling water pump can be linked at the time of operation.
- ※ In addition, the automatic blocking valve should be installed to prevent the water flow on the cooling water pipe of the chiller if several cooling water pipes are connected in parallel. Then, the automatic blocking valve should be operated in line with the LG control device. To link the automatic blocking valve, the valve should be opened/closed in synchronization with the cooling water pump run/stop signal provided by the control panel.
- For more details, please contact LG service center in advance.

| Chiller protection device |

- Evaporator low pressure
- Condenser high pressure
- Differential oil pressure
- Low chilled water flow
- Evaporator low temperature
- Condenser high temperature
- Overcurrent protection
- Compressor overheat protection

| Motor/Compressor protector |

- A reverse phase/phase loss protection relay
- A three-phase wire-wound temperature monitoring S/W
- A compressor discharge temperature monitoring sensor

2.10 Accessories and options

Some accessories and options supersede standard product features. All options are factory-mounted unless otherwise noted.

| Gateway |

Provides communication for Building Automation Systems, including BACnet (MS/ TP), Modbus, (Field Commissioned by BAS Manufacturer)

| General Options |

1. Flow Switch: The water flow switch comes with SPDT output function, 1.6MPa (232 psi) working pressure, -10°C to 120°C (-14°F to 248°F) with 1" NPT connection for upright mounting in horizontal pipe (This flow switch or equivalent must be furnished with each unit). Field mounted.
2. Differential Pressure Switch: 0.2-3 bar (3-45 psig) range with 1/4" NPTE pressure connections. (Field Mounted by Contractor.)

| Vibration Isolation (All Options Field Mounted by Contractor |
1" Deflection Spring Isolators: Level adjustable, spring and cage type isolators for mounting under the unit base rails.

| Compressor acoustic enclosure |

The compressor acoustic enclosure can be provided as a option to reduce compressor sound levels.

| Single power point connection |

For models installed with 2, 3 and 4 compressors, to minimize job site installation cost and time, single point power connection can be provided as an option about the following models. If optional single point power connection is required, terminal block connections will be supplied at the point of incoming single point connection.

| Power factor correction |

Provide equipment with power factor correction capacitors as required to maintain a displacement power factor of 95% at all load conditions.

| Double thickness insulation |

As a standard, the evaporator shell is insulated with 19mm (3/4"). As a option, it can be insulated with 38mm (1-1/2").

| NFB (Non-Fused Breaker) power disconnect switch |

A non-fused disconnect is available as a factory-installed option for all units with single point power connection units. This option is that power supply is disconnected during service & repair work as well as door interlock.

| Suction service isolation valve |

Service suction isolation valve is installed with unit for each refrigerant circuit as a standard.

| Pressure vessel (options) |

The evaporator and condenser can be provided with either ASME or PED pressure vessel codes certification.

instructions. Adjust and level chiller on support structure.

- C. Components: installing contractor shall provide and install all auxiliary devices and accessories for fully operational chiller.
- D. Electrical: coordinate electrical requirements and connections for all power feeds with electrical contractor.
- E. Controls: coordinate all control requirements and connections with controls contractor.
- F. Finish: installing contractor shall paint damaged and abraded factory finish with touch-up paint matching factory finish.

Part 3 – Execution

3.01 Installation

- A. General: rig and install in full accordance with manufacturer's requirements, project drawings, and contract documents.
- B. Location: locate chiller as indicated on drawings, including cleaning and service maintenance clearance per manufacturer



LG Electronics, Home appliance & Air solution company

Two IFC, 10 Gukjegeumyung-ro, Yeongdeungpo-gu, Seoul, 150-945, Korea.

www.lg.com

www.lgeaircon.com