

LG HVAC SOLUTION
ABSORPTION
CHILLER

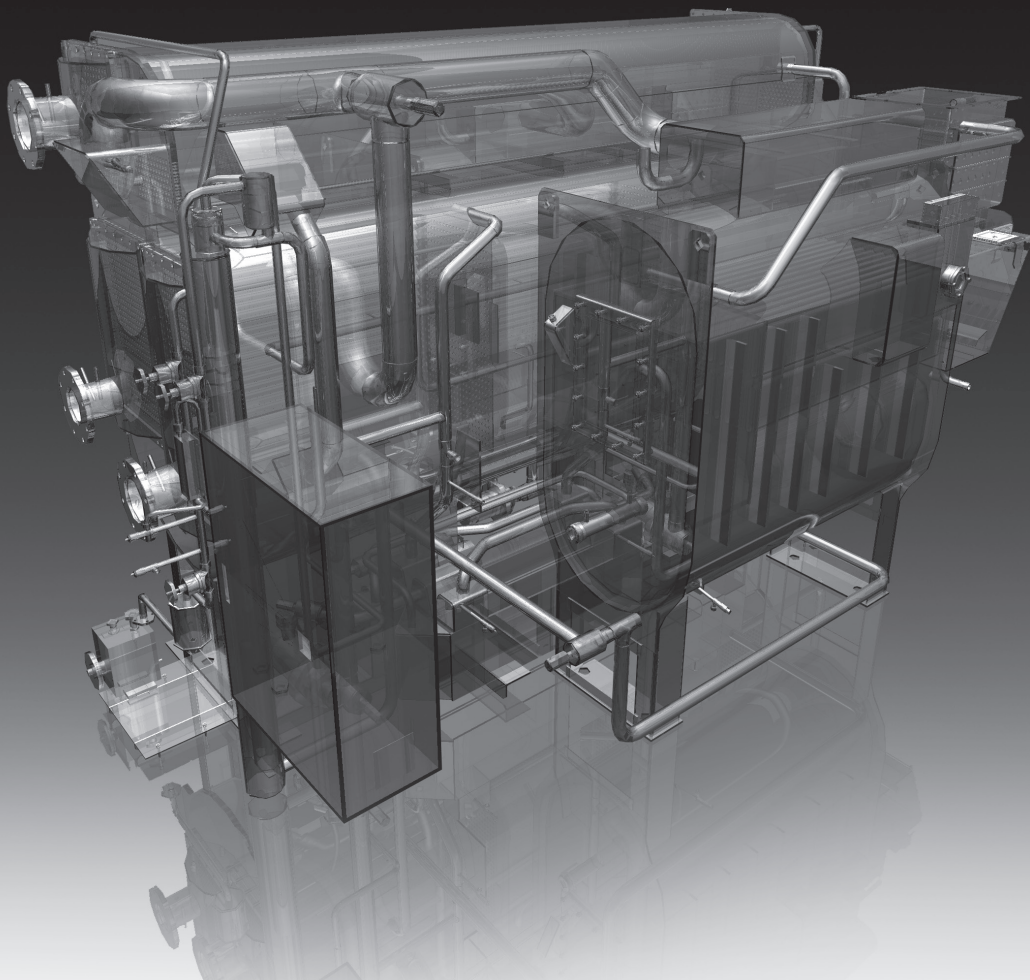

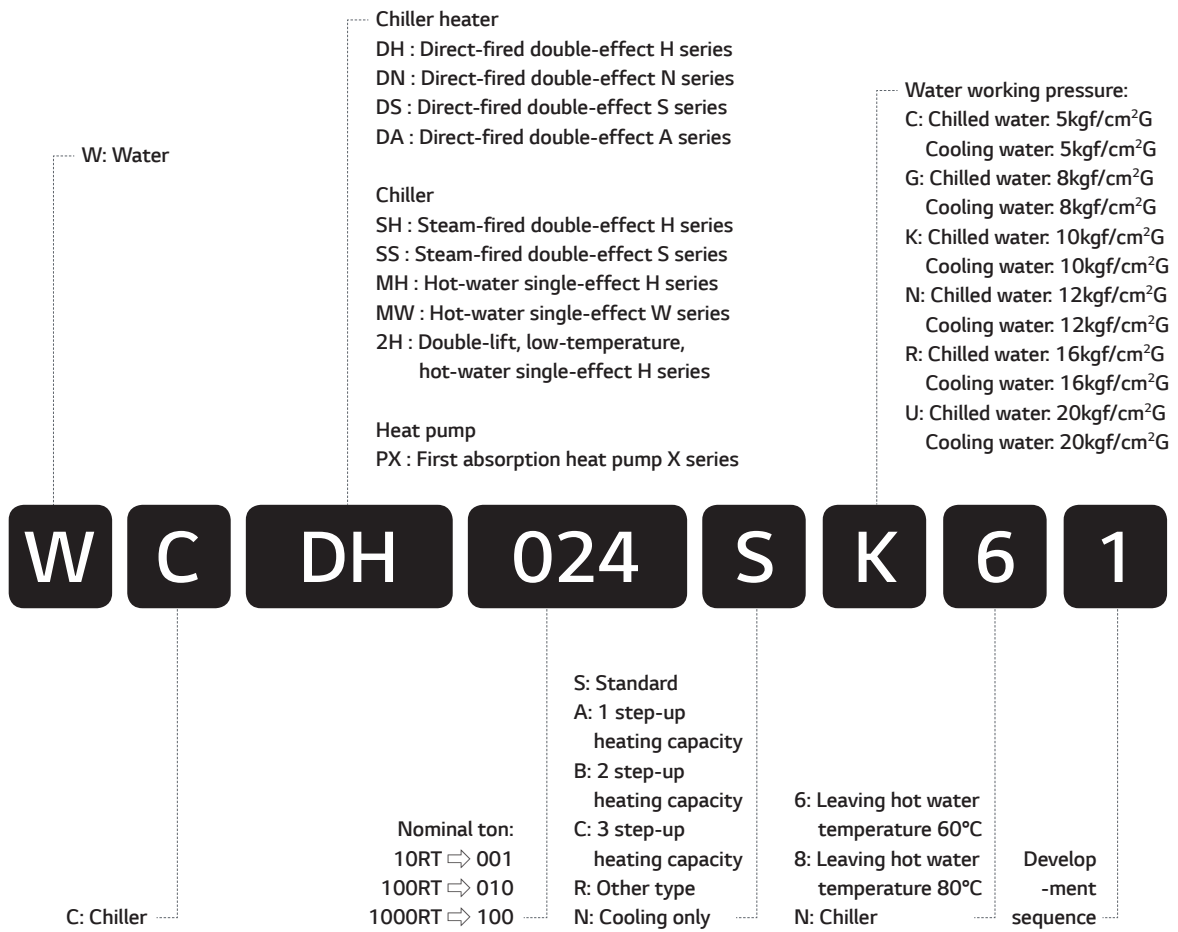



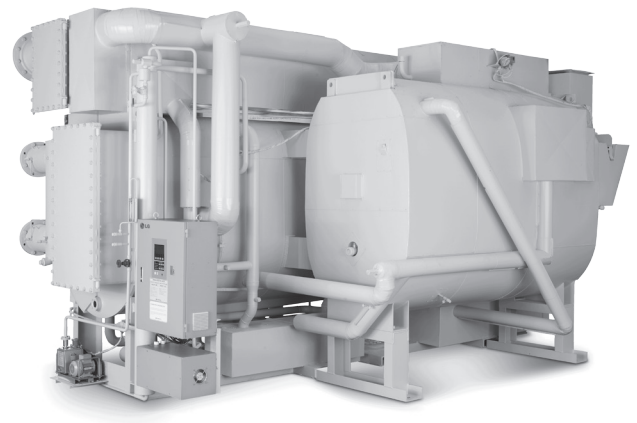

Contents

- 02 Nomenclature
- 03 Line up
- 04 Absorption chiller application
- 05 Equipment overview
- 09 Options
- 10 Specification
- 29 Absorption chiller cycle
- 30 Specification
- 38 Thermal insulation
- 40 Piping diagram
- 43 Control diagram of cooling water inlet temperature
- 44 Standard of water quality
- 45 Fuel piping
- 46 Multi-Sectional shipment
- 48 Outline & Foundation
- 73 Schematic diagram
- 78 Interface diagram







Line up

Direct fired absorption chiller & heater

Model		0	100	500	1,000	1,500	3,000
	WCDH (H Series)		100RT		1,500RT		3,000RT
	WCDN (N Series)		50RT	700RT			3,000RT
	WCDS (S Series)		100RT		1,500RT		3,000RT
	WCDA (A Series)		50-80RT				

Absorption chiller

Model		0	100	500	1,000	1,500	4,000
	WCSH Steam fired		100RT		1,500RT		4,000RT
	WCSS Steam fired		100RT		1,500RT		4,000RT
	WCMW Hot water fired		28RT		1,020RT		2,000RT
	WC2H Hot water fired		73RT		1,350RT		2,000RT
	WCMH Hot water fired		28RT		1,020RT		2,000RT

Heat pump

Model		0	300	1,000	5,000	10,000	20,000	30,000
	WCPX Heat pump		349kW					30,218kW

 * Available on request.

Absorption chiller application

	Energy	Available	Model Selection			(Example) Application
			Efficiency	Model	Remark	
Chiller	Gas or Oil	LNG LPG Bio-Gas Exhaust gas Oil	COP 1.51	WCDH	World class high efficiency	Commercial area Multipurpose building Thermoelectric power plant
			COP 1.34	WCDN	Enhanced stability & reliability	
			COP 1.12	WCDS	Steady best selling model	
	Steam	Steam pressure 4-8kg/cm ²	COP 1.50 Consumption (3.5 kg/hRT)	WCSH	World Class High Efficiency Steam Pressure : 4 ~ 8kg/cm ²	Commercial area Multipurpose building Petroleum and Chemical Factory
			COP 1.21 Consumption (4.4 kg/hRT)	WCSS	Steady Best Selling Model Steam Pressure : 4 ~ 8kg/cm ²	
			COP 0.80	WCMH	World Class High Efficiency Outlet Temp. : 85 ~ 75°C	
	Hot Water	Inlet Temperature Standard 95°C (130 ~85°C)	COP 0.72	WCMW	Steady Best Selling Model Outlet Temp. : 85 ~ 70°C	Solar system District energy system Cogeneration
			COP 0.74	WC2H	Low Temperature outlet Outlet Temp. : 70 ~ 55°C	
Heat pump	Waste heating Source	Gas Steam Hot water	COP 1.65-1.80	WCPX	World Class High Efficiency Hot water Temp. : 55 ~ 90°C	Combined Heat and Power Incinerator system

With over 50% domestic market share, LG Electronics has provided heating, ventilating and air conditioning total solution to industrial and commercial fields over 40 years. Now the company, specialized in absorption, centrifugal & GHP, now wants to share its leading technology with the global friends.

The LG Absorption Chillers have always been nation's No.1 energy saving chillers, since the company has considered R&D as frontier mover of all.

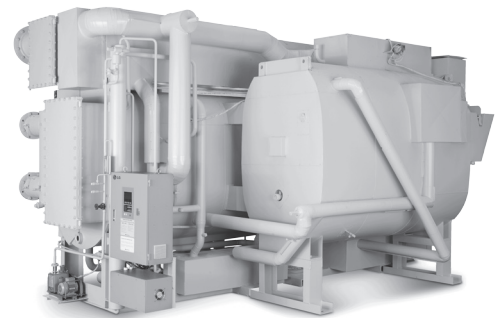

Features of LG absorption chillers

- Beneficial where cooling/heating demands are all year around by using diversified energy sources as Gas, Steam and Hot water.
- Reduces operation cost in where electrical costs are high.
- Utilizing environmental safe, non chlorine mixture based refrigerant.
- Reduces green house effect by less using hydrocarbon fuels as well as electricity.

Stainless steel tube

Corrosion resistance

In general, tubes of absorption chiller are corroded by pollutant in the cooling water.

The type of corrosion is majority pitting corrosion. So many maker recommend triennial cleaning tubes.

LG has applied to stainless steel tube and enhanced reliability, maintenance of machine.

- Main characteristic of corrosion in tube: pitting corrosion
If the pollutants is pasted at a tube surface, pollutants can be

lead to pitting corrosion.

- Enhanced heat-transfer efficiency of stainless steel tube
Generally, stainless steel tube has low heat transfer coefficient than copper.
LG has achieved same performance comparing to copper by improving low heat transfer efficiency of stainless steel with our unique knowhow
- Strength and hardness of stainless steel tube is higher than that of copper tube.

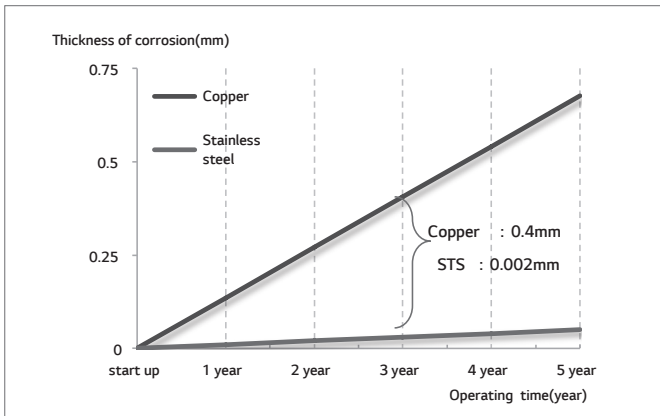

	Copper	Stainless steel
Corrosion rate (mm/year)	2400% (0.1352700)	100% (0.0056209)
Loss by weight (mg/year)	1500% (-0.0196)	100% (-0.00013)

Reinforced user interface design

Over 40 years experience with successful delivery of 10,000 units. LG Absorption chiller has been focused on user interface and reliable convenient operations that to considered as a first step of total HVAC solution.

High efficiency & high energy saving operation

Inverter controlled solution pump enabled high part-load efficiency with fast full-loaded operation

Optimized flow rate of solution is decided upon cooling demand and that to enable highly efficient energy saving operation at all operation range.

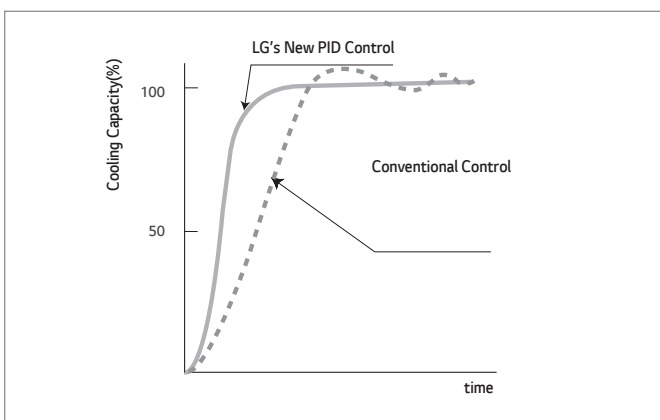

Reinforced safety operation function

LG's unique microprocessor keeps monitoring every part of chiller so to prevent any damage could happen at abnormal operation. The machine can stop automatically by reinforced

safety function when the chiller operation reached at abnormal state.

Optimized dilution operation shortened stoppage time

LG's newly designed microprocessor decides when to equalize concentration of solution in every part of chiller by self diagnostic calculations. Also this led to saving dilution operation as well as energy saving at auxiliary equipments, such as water pumps by reducing idle time from 15 min to 5 min.

High reliability & practical design

High performance of purging system

Newly designed injector typed, purging either at upper shell and lower shell, a new LG purging system, enabled less purging time and better purging performance.

Marine hatch type water box

No need to cut or disassemble for tube cleaning or maintenance purposes, marine hatch typed water box allows an operator to clean tubes in less time.

Series flow

- Easy control of absorbent circulation rate by load
- Reduce Facility installation cost by reduce cooling water flow
- Enable absorbent circulation rate control and Pump Soft Start/Stop by inverter pump
- Easy operation
- No damage by local heating

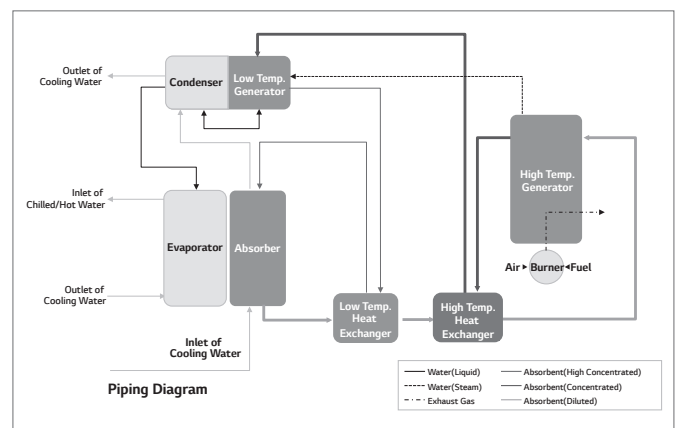

High performance controller

Delicate Designed with PID Control Logic, a new Micro Processor enables LG Chiller be always at optimum operation state

A new quick response PID control logic

A quick response, new LG designed PID algorithm enabled high sensitive combustion control rate that to meet minimized reaching time of demand temperature.

It also reduced the fluctuating temperature difference so that to enable constant temperature control logic.

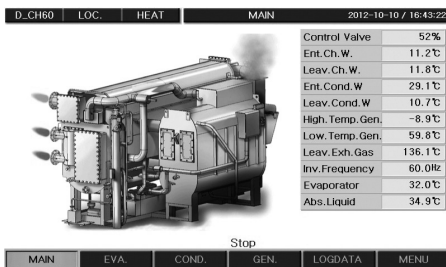
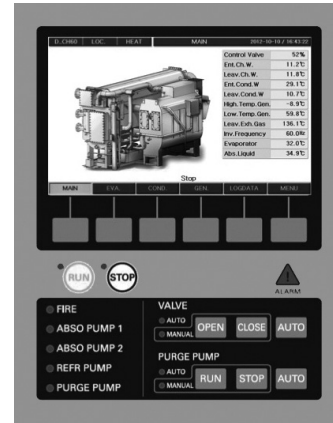

7" Color LCD with high resolution

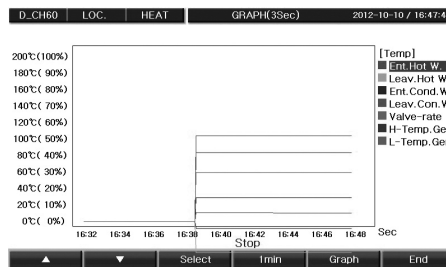

Real time operation status

SCHEDULE RUN SET	1	2	3	4	5
1 RUN 08:00 STOP 08:00					
2 RUN 08:00 STOP 08:00					
3 RUN 08:00 STOP 08:00					
4 RUN 08:00 STOP 12:00					
5 RUN 12:00 STOP 18:00					
6 RUN 18:00 STOP 18:00					
7 RUN 18:00 STOP 21:00					
8 RUN 21:00 STOP 23:00					

Time schedule



Evaporator & absorber



Low temperature generator

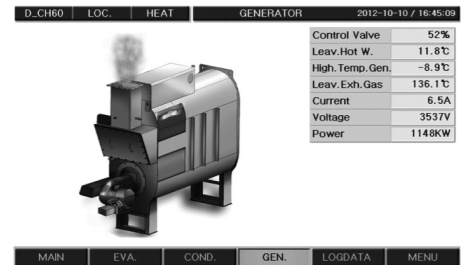

High temperature generator

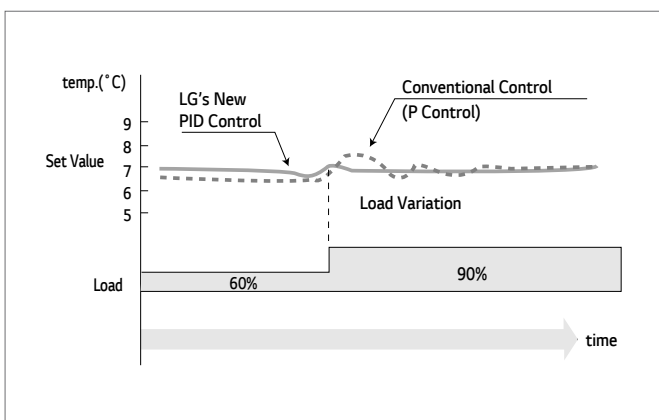

A new Quick Response PID Control Logic

Self diagnostic safety operation

1. Anti-crystallization safety operation

A solution concentration is monitored at micro processor in

all operational condition and keeps concentration level in optimum state by controlling a combustion rate.

2. A safety operation feature against cooling water temperature
For stable operation, entering cooling water can be reset based on remote temperature range of 19~34°C as well as responding its temperature at the micro processor by controlling combustion rate.

3. Operation data storage/maintenance feature

- 20 years normal operation history data record
- 300 abnormal message history data record
- 10.6 day temperature sensing data record

Based on all stored data, more accurate operational maintenance is capable.

4. Self Diagnostics / Mal function Alarm feature

If any disturbing factor predicted while normal operation, a chiller tests itself and determines whether it has to turn into

safe mode operation or to stop.

- Maintenance purpose

Chamber Cleaning: by monitoring exhaust gas temperature, operators can predict right time of cleaning a combustion channel of HTG.(Option)

- Malfunction alarm feature

Monitoring all sensors, of their conditions like temperatures and pressure state so that if any abnormal sign occurs it shows abnormal reason on the display for easy operation.

Absorbent concentration control

Controller calculates Absorbent Concentration by Condenser and Low Temp. Generator, Controls Inlet Heat for Preventing Absorbent Crystallization.

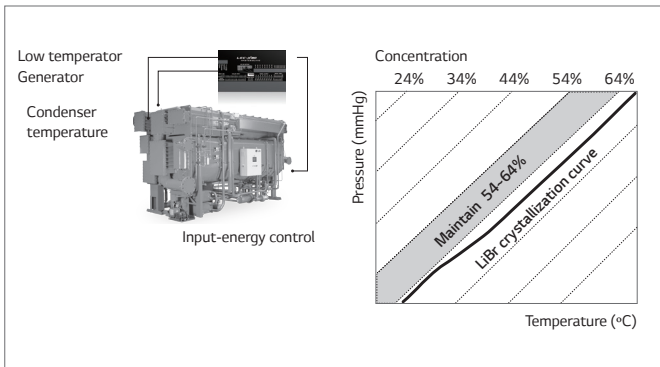

Process during Power failure

Auto Self Diagnosis and Restart by Blackout Response Function.

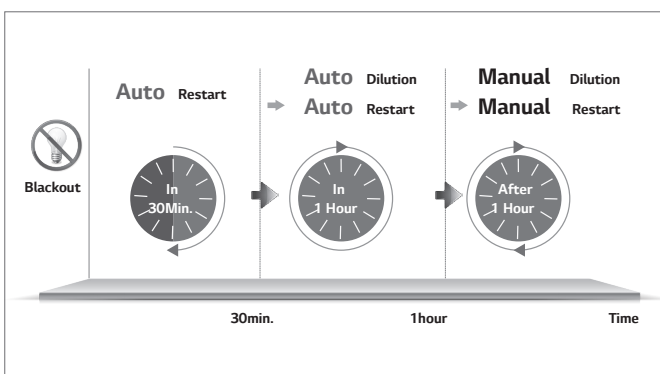

Maximize System Stability by Self Diagnosis

- Equipment Facility, Self Diagnosis

Equipment Facility from Controller when Start-up (Chilled water / Cooling water pump, Cooling tower) with Self diagnosis, Customer can prevent from Crystallization and Frozen burst.

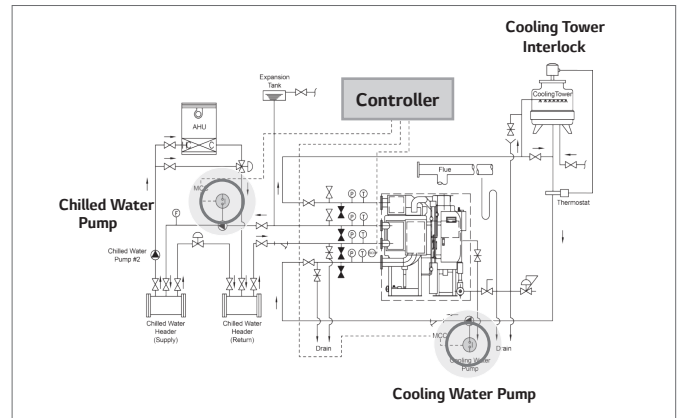

Equip. Facility Diagram

- Safety Device, Self Diagnosis

Safety device and Sensor status with Self-diagnosis from Controller when Start-up. Customer can prevent from abnormal operation and safety accident.

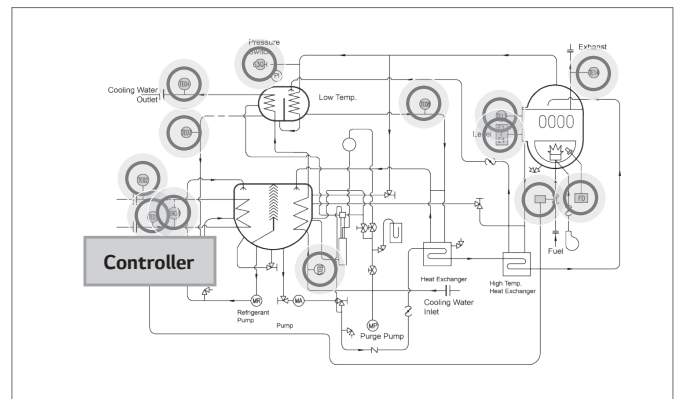

Piping Diagram

Enhanced user interface designed micro processor

- Operation State Display

Operation state is displayed either in text or as graph so to enable better understanding

- Printer(Optional)

Stored operation normal/abnormal/ alarm history data can be printed out from mounted printer

- Flow Rate Indication(Optional)

A flow rate of chilled/ cooling water flow rate can be indicated on the display. For this operation an additional transducer should be applied on chilled/cooling water pipe line.

- Annex System Control

Pumps and cooling fan are in control with micro processor for automated operation

- Schedule Operation

Schedule operation can be done in days or at the desired any time

Status Display (LED display) <ul style="list-style-type: none"> · Voltage · Run · Stop · Cooling · Heating 	Setting Value <ul style="list-style-type: none"> · CHW/HW inlet temp. · CHW/HW outlet temp. · CW temp. · P value · I value · D value 	
Reading Value (LCD display) <ul style="list-style-type: none"> · CHW/HW Inlet Temp. · CHW/HW Outlet Temp. · CW Inlet Temp. · H.gen Temp. · L.gen Temp. · Condensing Temp. · Remote Set Temp. · Control V/V Open(%) · Libr Concentration · Inverter(Hz) · PID Value 		
Operation Time (LCD display) <ul style="list-style-type: none"> · Running time · Combustion time · Ref. Pump run time · Abs pump #1 run time · Abs pump #2 run time 		Reading Value (LCD display) <ul style="list-style-type: none"> · Combustion signal · Purge chamber pressure · H. Gen level low · Run mode · Control v/v mode · Abs pump #1 th. Relay · Abs pump #2 th. Relay · Chw/hw pump interlock · Cw pump interlock · H. Gen pressure · Chw flow rate · Cw flow rate · Abs pump #1 m. Contactor · Abs pump #2 m. Contactor · Purge pump m. Contactor
No. Of Run/stop (LCD display) <ul style="list-style-type: none"> · Running time · Combustion time · Ref. Pump run time · Abs pump #1 run time · Abs pump #2 run time 		

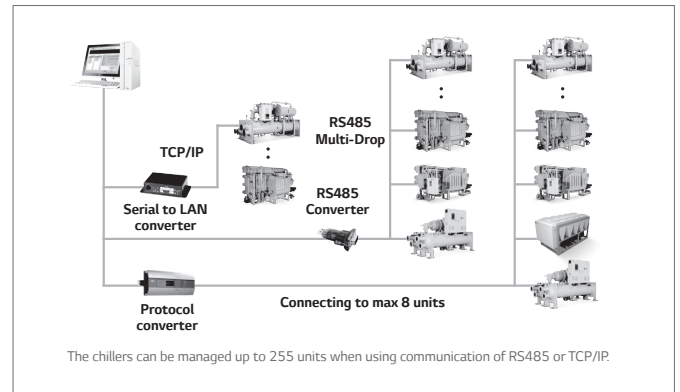

Detailed diagrams of BMS

Group unit system control

For intelligent buildings and huge factories

1. Communication protocol for Building Automation and Remote monitoring control
 - Easily accessible to user's interface
 - RS485 communication processor installed
 - MODBUS is standard, BACnet, Lonwork are available as an option.
 - Operational data acquisition
 - Graphical display of monitoring & control status
 - Data editing and Report generation with MS EXCEL
 - Real-time graphical display of trend data
 - Various graphic display for analog data
 - Password protected
2. Optimized Operation
 - Integrated System Management
 - Integrated control of Chillers and Peripheral Equipment which are connected to LG controller
 - Preventative Maintenance
 - Log data management
 - : Daily report generation of operation data, abnormal data and etc.
 - Operational Cost Saving
 - Cost saving through centralized monitoring
 - Auxiliary Function
 - Control of peripheral equipment, load control

Options

Items	Option
Refrigerant charging	√
Leaving chilled water temperature is available from 5°C	
Entering cooling water temperature is available from 22°C	
BACnet/Lonworks protocol converter module	√
Flexible Wiring	√
Dual Burner (LNG + Oil or LPG + Oil)	√
Factory completed thermal insulation	√
Factory performance test with witness	√
Sectional shipment	√
Wood Packing	√
Extended warranty	√
Solution Filter	√
Pump Inlet/Outlet shut-off valve	√
Auto purge system	√
Refrigerant temperature sensor	√
Companion flange	√
Cooling water outlet temperature sensor	√
Special construction for hazardous-area installation	√
Outdoor installation construction (non-hazardous areas)	√
Enclosure protection upgrade(IP54)	√

WCDH Series

Model name			010	012	015	018	021	024	028	032	036	040	045	050	
Cooling capacity	USRT		100	120	150	180	210	240	280	320	360	400	450	500	
	kW		352	422	527	633	738	844	985	1,125	1,266	1,407	1,582	1,758	
Heating capacity	kcal/h		253,000	253,000	303,600	379,500	455,400	531,300	607,200	708,400	809,600	910,800	1,012,000	1,138,500	
	kW		294	294	353	441	530	618	706	824	941	1,059	1,177	1,324	
Chilled water data	Temperature	°C	12 → 7.0												
	Water flow rate	m ³ /h	60.5	72.6	90.7	108.9	127	145.2	169.3	193.5	217.7	241.9	272.2	302.4	
	Pressure drop	mAq	6.2	6.3	8.0	8.3	8.0	8.1	5.4	5.5	5.6	5.8	5.1	5.2	
	Connection size	A(mm)		100	100	100	100	125	125	150	150	150	150	200	200
		B(inch)		4	4	4	4	5	5	6	6	6	6	8	8
Hot water data	Temperature	°C	56.2 → 60.0												
	Water flow rate	m ³ /h	60.5	72.6	90.7	108.9	127	145.2	169.3	193.5	217.7	241.9	272.2	302.4	
	Pressure drop	mAq	6.2	6.3	8.0	8.3	8.0	8.1	5.4	5.5	5.6	5.8	5.1	5.2	
	Connection size	A(mm)		100	100	100	100	125	125	150	150	150	150	200	200
		B(inch)		4	4	4	4	5	5	6	6	6	6	8	8
Cooling water data	Temperature	°C	32.0 → 37.0												
	Water flow rate	m ³ /h	100	120	150	180	210	240	280	320	360	400	450	500	
	Pressure drop	mAq	3.9	4.2	6.1	6.9	6.1	6.6	8.3	8.8	7.4	8.0	8.8	9.7	
	Connection size	A(mm)		125	125	125	125	150	150	200	200	200	200	250	250
		B(inch)		5	5	5	5	6	6	8	8	8	8	10	10
Fuel (Gas)	Nozzle size	A(mm)	40 (at 4,000mmAq)										50 (at 4,000mmAq)		
		B(inch)	1 1/2 (at 4,000mmAq)										2 (at 4,000mmAq)		
	Cooling	Nm ³ /h	21.4	25.7	32.1	38.5	44.9	51.3	59.9	68.4	77.0	85.5	96.2	106.9	
	Heating	Nm ³ /h	27.5	27.5	33.0	41.2	49.4	57.7	65.9	76.9	87.9	98.9	109.9	123.6	
Electrical data	Source	V	3ø 220/380/440V, 50Hz/60Hz												
	Total current	A	12.2	12.2	15.6	15.6	16.8	16.8	23.9	23.9	23.9	26.9	26.9	26.9	
	Wire size	mm ²	4	4	4	4	4	4	6	6	10	10	10	10	
	Power	kVA	8.2	9.1	10.6	11.2	12.1	12.1	15.9	17.9	19.8	19.8	17.7	17.7	
	Absorbent pump no.1	kW(A)	1.5(5.43)	1.5(5.43)	2.4(6.4)	2.4(6.4)	2.4(6.4)	2.4(6.4)	3.4(10.3)	3.4(10.3)	3.4(10.3)	3.4(10.3)	3.4(10.3)	3.4(10.3)	
	Absorbent pump no.2	kW(A)	0.4(1.6)	0.4(1.6)	1.2(4.0)	1.2(4.0)	1.2(4.0)	1.2(4.0)	1.5(5.5)	1.5(5.5)	1.5(5.5)	1.5(5.5)	2.0(5.2)	2.0(5.2)	
	Refrigerant pump	kW(A)	0.2(1.1)	0.2(1.1)	0.2(1.1)	0.2(1.1)	0.2(1.1)	0.2(1.1)	0.4(1.4)	0.4(1.4)	0.4(1.4)	0.4(1.4)	0.4(1.4)	0.4(1.4)	
	Purge pump	kW(A)	0.4(1.45)	0.4(1.45)	0.4(1.45)	0.4(1.45)	0.4(1.45)	0.4(1.45)	0.4(1.45)	0.4(1.45)	0.4(1.45)	0.4(1.45)	0.4(1.45)	0.4(1.45)	
	Burner blower (gas)	kW(A)	0.72(2.1)	0.72(2.1)	0.72(2.1)	1.5(3.3)	1.5(3.3)	1.5(3.3)	2.2(4.7)	2.2(4.7)	2.2(4.7)	3.7(7.7)	3.7(7.7)	3.7(7.7)	
Dimension	Length	mm	2,895	2,895	3,745	3,745	3,795	3,795	4,815	4,815	4,890	4,890	4,900	4,900	
	Width	mm	1,965	1,965	1,965	2,095	2,150	2,170	2,225	2,225	2,430	2,515	2,765	2,855	
	Height	mm	2,070	2,070	2,070	2,070	2,415	2,415	2,415	2,415	2,590	2,590	2,925	2,925	
Rigging	Operating	ton	4.9	5.2	6.2	6.9	8.0	8.6	10.4	10.9	12.4	13.2	15.5	17.3	
	Total shipping	ton	4.7	4.9	5.8	6.4	7.3	7.9	9.5	10.0	11.1	11.9	13.9	15.6	
	Flue Connection Size	ton	3.8	4.0	4.6	5.0	5.8	6.1	7.4	7.8	8.7	9.4	11.0	12.4	
Flue connection size	mm	340 x 320	340 x 320	340 x 320	340 x 320	340 x 320	380 x 430	380 x 430	380 x 430	380 x 430	450 x 430	450 x 430	520 x 550		
Clearance for tube removal	mm	2,400	2,400	3,400	3,400	3,400	3,400	4,500	4,500	4,500	4,500	4,500	4,500		

Note:

1. 1usRT = 3,024kcal/h, 1kW = 860kcal/h
2. Standard Tube and Water Side Pressure(Chiller & Cooling Water Circuit): 10kg/cm²G(981kPa)
3. Standard gas pressure : 4,000mmAq
4. Standard low calorific value : 9,360 kcal/N m³
5. Currents & Electricity Consumptions are based on 3ø 380V 60Hz
6. Power supply wire size is based on the due of metal conduit and 40° C of ambient temperature.
7. The specifications are subject to change without prior notice.
8. Fouling factor of water side: 0.0001 m² hr C/kcal

WCDH Series

Model name		056	063	070	080	090	100	110	120	130	140	150	
Cooling capacity	USRT	560	630	700	800	900	1,000	1,100	1,200	1,300	1,400	1,500	
	kW	1,969	2,215	2,461	2,813	3,165	3,516	3,868	4,220	4,571	4,923	5,274	
Heating capacity	kcal/h	1,265,000	1,416,800	1,593,900	1,771,000	2,024,000	2,277,000	2,530,000	2,783,000	3,036,000	3,289,000	3,542,000	
	kW	1,471	1,647	1,853	2,059	2,353	2,648	2,942	3,236	3,530	3,824	4,119	
Chilled water data	Temperature	°C 12 → 7.0											
	Water flow rate	m ³ /h	338.7	381	423.4	483.8	544.3	604.8	665.3	725.8	786.2	846.7	907.2
	Pressure drop	mAq	5.2	7.2	9.6	4.4	6.0	7.9	5.8	6.1	9.2	7.6	9.3
	Connection size	A(mm)	200	200	200	250	250	250	300	300	300	350	350
		B(inch)	8	8	8	10	10	10	12	12	12	14	14
Hot water data	Temperature	°C 56.2 → 60.0											
	Water flow rate	m ³ /h	338.7	381	423.4	483.8	544.3	604.8	665.3	725.8	786.2	846.7	907.2
	Pressure drop	mAq	5.2	7.2	9.6	4.4	6.0	7.9	5.8	6.1	9.2	7.6	9.3
	Connection size	A(mm)	200	200	200	250	250	250	300	300	300	350	350
		B(inch)	8	8	8	10	10	10	12	12	12	14	14
Cooling water data	Temperature	°C 32.0 → 37.0											
	Water flow rate	m ³ /h	560	630	700	800	900	1,000	1,100	1,200	1,300	1,400	1,500
	Pressure drop	mAq	8.9	11.9	15.3	6.9	9.3	12.3	9.2	11.7	14.6	11.4	13.9
	Connection size	A(mm)	300	300	300	350	350	350	400	400	400	400	400
		B(inch)	12	12	12	14	14	14	16	16	16	16	16
Fuel (Gas)	Nozzle size	A(mm)	50 (at 4,000mAq)					65 (at 4,000mAq)					
		B(inch)	2 (at 4,000mAq)					2 1/2 (at 4,000mAq)					
	Cooling	Nm ³ /h	119.7	134.7	149.7	171.0	192.4	213.8	235.2	256.6	277.9	299.3	320.7
	Heating	Nm ³ /h	137.4	153.8	173.1	192.3	219.8	247.2	274.7	302.2	329.6	357.1	384.6
Electrical data	Source	V	3ø 220/380/440V, 50Hz/60Hz										
	Total current	A	35.7	35.7	35.7	44.4	49.4	55.9	73.7	73.7	73.7	73.7	73.7
	Wire size	mm ²	16	16	16	16	25	35	35	35	35	35	35
	Power	kVA	23.5	23.5	23.5	29.2	32.5	36.8	48.5	48.5	48.5	48.5	48.5
	Absorbent pump no.1	kW(A)	6.6(16.2)	6.6(16.2)	6.6(16.2)	5.5(20.0)	7.5(25.0)	7.5(25.0)	7.5(25.0)	7.5(25.0)	7.5(25.0)	7.5(25.0)	7.5(25.0)
	Absorbent pump no.2	kW(A)	2.0(5.2)	2.0(5.2)	2.0(5.2)	2.2(6.7)	2.2(6.7)	2.2(6.7)	5.5(21.0)	5.5(21.0)	5.5(21.0)	5.5(21.0)	5.5(21.0)
	Refrigerant pump	kW(A)	0.4(1.4)	0.4(1.4)	0.4(1.4)	0.4(1.4)	0.4(1.4)	0.4(1.4)	1.5(3.9)	1.5(3.9)	1.5(3.9)	1.5(3.9)	1.5(3.9)
	Purge pump	kW(A)	0.4(1.45)	0.4(1.45)	0.4(1.45)	0.4(1.45)	0.4(1.45)	0.4(1.45)	0.75(2.5)	0.75(2.5)	0.75(2.5)	0.75(2.5)	0.75(2.5)
	Burner blower (gas)	kW(A)	5.5(10.6)	5.5(10.6)	5.5(10.6)	7.5(14.0)	7.5(14.0)	7.5(14.0)	11.0(20.5)	11.0(20.5)	11.0(20.5)	11.0(20.5)	11.0(20.5)
Dimension	Length	mm	5,310	5,520	6,010	5,610	6,200	6,700	6,200	6,700	7,200	6,850	7,350
	Width	mm	3,025	3,150	3,150	3,800	4,050	4,050	4,400	4,400	4,400	4,800	4,800
	Height	mm	3,295	3,295	3,295	3,550	3,600	3,600	3,800	3,800	3,800	3,900	3,900
Rigging	Operating	ton	21.2	24.4	27.2	31.6	33.9	37.1	40.4	44.1	48.1	52.1	55.9
	Total shipping	ton	18.7	21.6	24.3	27.8	29.7	32.7	36.1	39.6	43.2	46.7	50.2
	Flue Connection Size	ton	15.0	17.5	19.5	21.0	22.5	24.0	26.0	28.0	30.0	32.0	34.0
Flue connection size	mm	520 x 550	650 x 550	650 x 550	650 x 550	750 x 550	750 x 550	750 x 550	850 x 550	850 x 550	850 x 550	950 x 550	
Clearance for tube removal	mm	4,500	5,200	5,700	5,200	5,700	6,200	5,700	6,200	6,700	6,200	6,700	

- Note:
- 1 usRT = 3,024kcal/h, 1kW = 860kcal/h
 2. Standard Tube and Water Side Pressure(Chiller & Cooling Water Circuit): 10kg/cm²G(981kPa)
 3. Standard gas pressure : 4,000mAq
 4. Standard low calorific value : 9,360 kcal/Nm³
 5. Currents & Electricity Consumptions are based on 3ø 380V 60Hz
 6. Power supply wire size is based on the due of metal conduit and 40 °C of ambient temperature.
 7. The specifications are subject to change without prior notice.
 8. Fouling factor of water side: 0.0001 m² hr C/kcal

WCDN Series

Model name			005	006	007	008	010	012	015	018	021	024	
Cooling capacity	USRT		50	60	70	80	100	120	150	180	210	240	
	kW		176	211	246	281	352	422	528	633	739	844	
Heating capacity	kcal/h		133,000	160,000	186,000	212,000	267,000	319,000	400,000	479,000	559,000	639,000	
	kW		155	186	216	247	311	371	465	557	650	743	
Chilled water data	Temperature	°C	12 → 7.0										
	Water flow rate	m ³ /h	30.3	36.3	42.4	48.4	60.5	72.6	90.7	108.9	127	145.2	
	Pressure drop	mAq	4.6	4.8	4.7	4.5	9.1	9.0	12.0	12.0	12.0	12.0	
	Connection size	A(mm)	80	80	80	80	100	100	100	100	125	125	
		B(inch)	3	3	3	3	4	4	4	4	5	5	
Hot water data	Temperature	°C	54 → 60.0					55.6 → 60.0					
	Water flow rate	m ³ /h	30.3	36.3	42.4	48.4	60.5	72.6	90.7	108.9	127	145.2	
	Pressure drop	mAq	4.6	4.8	4.7	4.5	9.1	9.0	12.0	12.0	12.0	12.0	
	Connection size	A(mm)	80	80	80	80	100	100	100	100	125	125	
		B(inch)	3	3	3	3	4	4	4	4	5	5	
Cooling water data	Temperature	°C	32.0 → 37.2										
	Water flow rate	m ³ /h	50	60	70	80	100	120	150	180	210	240	
	Pressure drop	mAq	5.8	6.3	4.8	5.4	4.5	4.5	7.0	8.0	6.5	7.0	
	Connection size	A(mm)	100	100	100	100	125	125	125	125	150	150	
		B(inch)	4	4	4	4	5	5	5	5	6	6	
Fuel (Gas)	Nozzle size	A(mm)	25 (at 200mmAq)		40 (at 200mmAq)			40 (at 4,000mmAq)					
		B(inch)	25 (at 200mmAq)		1 1/2 (at 200mmAq)			1 1/2 (at 4,000mmAq)					
	Cooling	Nm ³ /h	12.0	14.4	16.8	19.2	24.0	28.8	36.0	43.3	50.5	57.7	
	Heating	Nm ³ /h	15.2	18.3	21.2	24.2	30.5	36.4	45.7	54.7	63.8	72.9	
Electrical data	Source	V	3ø 220/380/440V, 50Hz/60Hz										
	Total current	A	8.2	8.2	9.5	9.5	12.2	12.2	15.6	16.8	16.8	16.8	
	Wire size	mm ²	4	4	4	4	4	4	4	4	4	4	
	Power	kVA	5.4	5.4	6.2	6.2	8.2	8.2	10.5	11.3	11.3	11.3	
	Absorbent pump no.1	kW(A)	1.2(4.1)	1.2(4.1)	1.2(4.1)	1.2(4.1)	1.5(5.43)	1.5(5.43)	2.4(6.4)	2.4(6.4)	2.4(6.4)	2.4(6.4)	
	Absorbent pump no.2	kW(A)	N/A	N/A	N/A	N/A	0.4(1.6)	0.4(1.6)	1.2(4.0)	1.2(4.0)	1.2(4.0)	1.2(4.0)	
	Refrigerant pump	kW(A)	0.2(1.1)	0.2(1.1)	0.2(1.1)	0.2(1.1)	0.2(1.1)	0.2(1.1)	0.2(1.1)	0.2(1.1)	0.2(1.1)	0.2(1.1)	
	Purge pump	kW(A)	0.4(1.45)	0.4(1.45)	0.4(1.45)	0.4(1.45)	0.4(1.45)	0.4(1.45)	0.4(1.45)	0.4(1.45)	0.4(1.45)	0.4(1.45)	
	Burner blower (gas)	kW(A)	0.37(1.0)	0.37(1.0)	0.74(2.3)	0.74(2.3)	0.72(2.1)	0.72(2.1)	0.72(2.1)	1.5(3.3)	1.5(3.3)	1.5(3.3)	
Dimension	Length	mm	2,205	2,205	2,555	2,555	3,165	3,165	3,745	3,665	3,705	3,795	
	Width	mm	1,685	1,685	1,860	1,860	2,000	2,045	2,095	2,095	2,150	2,170	
	Height	mm	1,760	1,760	1,760	1,760	2,070	2,070	2,070	2,070	2,415	2,415	
Rigging	Operating	ton	3.2	3.4	3.8	4.0	4.9	5.2	6.2	6.8	8.0	8.5	
	Total shipping	ton	1.9	2.0	2.1	2.2	3.8	4.0	4.6	5.0	5.8	6.1	
	Flue Connection Size	ton	2.3	2.5	2.7	2.9	4.6	4.9	5.8	6.4	7.3	7.7	
Flue connection size	mm	190 x 100	190 x 100	270 x 150	270 x 150	280x210	280x210	280x210	280x210	310x310	310x310		
Clearance for tube removal	mm	1,700	1,700	2,200	2,200	2,400	2,400	3,400	3,400	3,400	3,400		

Note:

1. 1usRT = 3,024kcal/h, 1kW = 860kcal/h
2. Standard Tube and Water Side Pressure(Chiller & Cooling Water Circuit): 10kg/cm²G(981kPa) (But, WCDN005-N008 : 5kg/cm²G(490kPa))
3. Standard gas prssure : 4,000mmAq
4. Standard low calorific value : 9,360 kcal/N m³
5. Currents & Electricity Consumptions are based on 3ø 380V 60Hz
6. Power supply wire size is based on the due of metal conduit and 40°C of ambient temperatue.
7. The specifications are subject to change without prior notice.
8. Fouling factor of water side: 0.0001 m² hr C/kcal

WCDN Series

Model name		028	032	036	040	045	050	056	063	070	
Cooling capacity	USRT	280	320	360	400	450	500	560	630	700	
	kW	985	1,125	1,266	1,407	1,583	1,758	1,969	2,216	2,462	
Heating capacity	kcal/h	745,000	852,000	958,000	1,064,000	1,198,000	1,330,000	1,490,000	1,676,000	1,863,900	
	kW	866	991	1,114	1,237	1,393	1,547	1,733	1,949	2,168	
Chilled water data	Temperature	°C 12 → 7.0									
	Water flow rate	m ³ /h	169.3	193.5	217.7	241.9	272.2	302.4	338.7	381	423.4
	Pressure drop	mAq	7.5	8.0	8.0	8.5	7.5	7.5	7.5	10.5	13.5
	Connection size	A(mm)	150	150	150	150	200	200	200	200	200
		B(inch)	6	6	6	6	8	8	8	8	8
Hot water data	Temperature	°C 55.6 → 60.0									
	Water flow rate	m ³ /h	169.3	193.5	217.7	241.9	272.2	302.4	338.7	381	423.4
	Pressure drop	mAq	7.5	8.0	8.0	8.5	7.5	7.5	7.5	10.5	13.5
	Connection size	A(mm)	150	150	150	150	200	200	200	200	200
		B(inch)	6	6	6	6	8	8	8	8	8
Cooling water data	Temperature	°C 32.0 → 37.2									
	Water flow rate	m ³ /h	280	320	360	400	450	500	560	630	700
	Pressure drop	mAq	8.5	9.0	7.5	8.0	9.0	10.0	9.0	12.0	15.5
	Connection size	A(mm)	200	200	200	200	250	250	300	300	300
		B(inch)	8	8	8	8	10	10	12	12	12
Fuel (Gas)	Nozzle size	A(mm)	40 (at 4,000mmAq)			50 (at 4,000mmAq)					
		B(inch)	1 1/2 (at 4,000mmAq)			2 (at 4,000mmAq)					
	Cooling	Nm ³ /h	67.3	76.9	86.5	96.1	108.1	120.2	134.6	151.4	168.2
	Heating	Nm ³ /h	85.0	97.2	109.3	121.4	136.7	151.8	170.1	191.3	212.7
Electrical data	Source	V	3ø 220/380/440V, 50Hz/60Hz								
	Total current	A	23.9	23.9	25.6	26.9	26.9	26.9	35.7	35.7	35.7
	Wire size	mm ²	6	6	10	10	10	10	16	16	16
	Power	kVA	14.9	15.9	15.9	17.9	17.9	17.9	23.5	23.5	23.5
	Absorbent pump no.1	kW(A)	3.4(10.3)	3.4(10.3)	3.4(10.3)	3.4(10.3)	3.4(10.3)	3.4(10.3)	6.6(16.2)	6.6(16.2)	6.6(16.2)
	Absorbent pump no.2	kW(A)	1.5(5.5)	1.5(5.5)	1.5(5.5)	1.5(5.5)	2.0(5.2)	2.0(5.2)	2.0(5.2)	2.0(5.2)	2.0(5.2)
	Refrigerant pump	kW(A)	0.4(1.4)	0.4(1.4)	0.4(1.4)	0.4(1.4)	0.4(1.4)	0.4(1.4)	0.4(1.4)	0.4(1.4)	0.4(1.4)
	Purge pump	kW(A)	0.4(1.45)	0.4(1.45)	0.4(1.45)	0.4(1.45)	0.4(1.45)	0.4(1.45)	0.4(1.45)	0.4(1.45)	0.4(1.45)
Dimension	Length	mm	4,725	4,725	4,890	4,890	4,900	5,205	5,050	5,495	6,005
	Width	mm	2,320	2,260	2,425	2,545	2,840	2,840	3,350	3,150	3,255
	Height	mm	2,415	2,415	2,590	2,590	2,925	2,925	3,295	3,295	3,295
Rigging	Operating	ton	10.2	10.9	12.4	13.3	15.6	17.4	21.3	24.5	27.6
	Total shipping	ton	7.4	7.8	8.7	9.4	11.0	12.4	15.0	17.5	19.5
	Flue Connection Size	ton	9.4	9.9	11.2	12.0	14.1	15.7	18.8	21.8	24.7
Flue connection size	mm	310x310	310x310	360x310	360x310	410x310	410x310	500x350	500x350	500x350	
Clearance for tube removal	mm	4,500	4,500	4,500	4,500	4,500	4,500	4,500	5,200	5,700	

Note:

1. 1usRT = 3,024kcal/h, 1kW = 860kcal/h
2. Standard Tube and Water Side Pressure(Chiller & Cooling Water Circuit): 10kg/cm²G(981kPa)
(But, WCDN005-N008 : 5kg/cm²G(490kPa))
3. Standard gas pressure : 4,000mmAq
4. Standard low calorific value : 9,360 kcal/Nm³
5. Currents & Electricity Consumptions are based on 3ø 380V 60Hz
6. Power supply wire size is based on the due of metal conduit and 40 °C of ambient temperature.
7. The specifications are subject to change without prior notice.
8. Fouling factor of water side: 0.0001 m² hr C/kcal

WCDS Series

Model name			010	012	015	018	021	024	028	032	036	040	045	050	
Cooling capacity	USRT		100	120	150	180	210	240	280	320	360	400	450	500	
	kW		352	422	528	633	739	844	985	1,125	1,266	1,407	1,583	1,758	
Heating capacity	kcal/h		253,000	303,600	379,500	455,400	531,300	607,200	708,400	809,600	910,800	1,012,000	1,138,500	1,265,000	
	kW		294	353	441	529	617	706	823	941	1,059	1,176	1,323	1,470	
Chilled water data	Temperature	°C	12 → 7.0												
	Water flow rate	m ³ /h	60.5	72.6	90.7	108.9	127.0	145.2	169.3	193.5	217.7	241.9	272.2	302.4	
	Pressure drop	mAq	6.5	6.6	8	8.3	7.5	7.9	5.1	5.5	5.8	6.1	5.2	5.5	
	Connection size	A(mm)		100	100	100	100	125	125	150	150	150	150	200	200
		B(inch)		4	4	4	4	5	5	6	6	6	6	8	8
Hot water data	Temperature	°C	55.8 → 60.0												
	Water flow rate	m ³ /h	60.5	72.6	90.7	108.9	127.0	145.2	169.3	193.5	217.7	241.9	272.2	302.4	
	Pressure drop	mAq	6.5	6.6	8	8.3	7.5	7.9	5.1	5.5	5.8	6.1	5.2	5.5	
	Connection size	A(mm)		100	100	100	100	125	125	150	150	150	150	200	200
		B(inch)		4	4	4	4	5	5	6	6	6	6	8	8
Cooling water data	Temperature	°C	32.0 → 37.5												
	Water flow rate	m ³ /h	100	120	150	180	210	240	280	320	360	400	450	500	
	Pressure drop	mAq	3.9	4.4	6.5	7.7	5.6	6.2	10.9	12.1	8.7	9.4	10.3	11.2	
	Connection size	A(mm)		125	125	125	125	150	150	200	200	200	200	250	250
		B(inch)		5	5	5	5	6	6	8	8	8	8	10	10
Fuel (Gas)	Nozzle size	A(mm)	40 (at 4,000mmAq)										50 (at 4,000mmAq)		
		B(inch)	1 1/2 (at 4,000mmAq)										2 (at 4,000mmAq)		
	Cooling	Nm ³ /h	28.9	34.6	43.3	52.0	60.6	69.3	80.8	92.4	103.9	115.5	129.9	144.4	
	Heating	Nm ³ /h	28.9	34.6	43.3	52.0	60.6	69.3	80.8	92.4	103.9	115.5	129.9	144.4	
Electrical data	Source	V	3ø 220/380/440V, 50Hz/60Hz												
	Total current	A	10.6	10.6	11.6	12.8	12.8	12.8	24.2	24.2	24.2	27.2	28.6	28.6	
	Wire size	mm ²	4	4	4	4	4	4	4	4	4	6	6	6	
	Power	kVA	7.0	7.0	7.6	8.4	8.4	8.4	15.9	15.9	15.9	17.9	18.8	18.8	
	Absorbent pump no.1	kW(A)	1.5(5.43)	1.5(5.43)	2.4(6.4)	2.4(6.4)	2.4(6.4)	2.4(6.4)	3.4(10.3)	3.4(10.3)	3.4(10.3)	3.4(10.3)	3.7(12.0)	3.7(12.0)	
	Absorbent pump no.2	kW(A)	n/a	n/a	n/a	n/a	n/a	n/a	1.5(5.5)	1.5(5.5)	1.5(5.5)	1.5(5.5)	2.0(5.2)	2.0(5.2)	
	Refrigerant pump	kW(A)	0.2(1.1)	0.2(1.1)	0.2(1.1)	0.2(1.1)	0.2(1.1)	0.2(1.1)	0.4(1.4)	0.4(1.4)	0.4(1.4)	0.4(1.4)	0.4(1.4)	0.4(1.4)	
	Purge pump	kW(A)	0.4(1.45)	0.4(1.45)	0.4(1.45)	0.4(1.45)	0.4(1.45)	0.4(1.45)	0.4(1.45)	0.4(1.45)	0.4(1.45)	0.4(1.45)	0.4(1.45)	0.4(1.45)	
	Burner blower (gas)	kW(A)	0.72(2.1)	0.72(2.1)	0.72(2.1)	1.5(3.3)	1.5(3.3)	1.5(3.3)	2.2(4.7)	2.2(4.7)	2.2(4.7)	3.7(7.7)	3.7(7.7)	3.7(7.7)	
Dimension	Length	mm	2,700	2,700	3,720	3,720	3,740	3,740	4,780	4,780	4,890	4,890	4,870	4,870	
	Width	mm	1,990	1,990	1,990	2,010	2,190	2,210	2,170	2,170	2,310	2,350	2,570	2,570	
	Height	mm	2,030	2,030	2,030	2,030	2,300	2,300	2,300	2,300	2,540	2,540	2,765	2,765	
Rigging	Operating	ton	4.8	5.1	6.1	6.7	7.9	8.2	9.2	9.8	12.3	12.7	16.4	17.4	
	Total shipping	ton	4.0	4.2	5.1	5.6	6.4	7.6	8.1	8.7	10.8	11.1	14.5	15.0	
	Flue Connection Size	ton	3.2	3.3	3.9	4.2	4.9	6.0	6.1	6.6	8.3	8.5	10.2	10.6	
Flue connection size	mm	280x210	280x210	280x210	280x210	310 x 310	310 x 310	310 x 310	310 x 310	360 x 310	360 x 310	410 x 310	410 x 310		
Clearance for tube removal	mm	2,400	2,400	3,400	3,400	3,400	3,400	4,500	4,500	4,500	4,500	4,500	4,500		

Note:

1. 1usRT = 3,024kcal/h, 1kW = 860kcal/h
2. Standard Tube and Water Side Pressure(Chiller & Cooling Water Circuit): 8kg/cm²G(785kPa)
3. Standard gas pressure : 4,000mmAq
4. Standard low calorific value : 9,360 kcal/N m³
5. Currents & Electricity Consumptions are based on 3ø 380V 60Hz
6. Power supply wire size is based on the due of metal conduit and 40° C of ambient temperature.
7. The specifications are subject to change without prior notice.
8. Fouling factor of water side: 0.0001 m² hr C/kcal

WCDS Series

Model name		056	063	070	080	090	100S	110	120	130	140	150	
Cooling capacity	USRT	560	630	700	800	900	1,000	1,100	1,200	1,300	1,400	1,500	
	kW	1,969	2,216	2,462	2,813	3,165	3,517	3,869	4,220	4,572	4,924	5,275	
Heating capacity	kcal/h	1,416,800	1,593,900	1,771,000	2,024,000	2,277,000	2,530,000	2,783,000	3,036,000	3,289,000	3,542,000	3,795,000	
	kW	1,647	1,852	2,058	2,352	2,646	2,940	3,234	3,529	3,823	4,117	4,411	
Chilled water data	Temperature	°C	12 → 7.0										
	Water flow rate	m ³ /h	338.7	381	423.4	483.8	544.3	604.8	665.3	725.8	786.2	846.7	907.2
	Pressure drop	mAq	5.2	7.1	9.4	5.5	7.5	9.9	7.5	9.6	11.9	9.7	11.9
	Connection size	A(mm)	200	200	200	250	250	250	300	300	300	350	350
		B(inch)	8	8	8	10	10	10	12	12	12	14	14
Hot water data	Temperature	°C	55.8 → 60.0										
	Water flow rate	m ³ /h	338.7	381	423.4	483.8	544.3	604.8	665.3	725.8	786.2	846.7	907.2
	Pressure drop	mAq	5.2	7.1	9.4	4.7	6.4	8.4	6.2	7.9	9.8	8.0	9.8
	Connection size	A(mm)	200	200	200	250	250	250	300	300	300	350	350
		B(inch)	8	8	8	10	10	10	12	12	12	14	14
Cooling water data	Temperature	°C	32.0 → 37.5										
	Water flow rate	m ³ /h	560	630	700	800	900	1,000	1,100	1,200	1,300	1,400	1,500
	Pressure drop	mAq	8	10.6	13.7	8.4	11.1	14.3	8.8	10.9	13.4	12.3	14.6
	Connection size	A(mm)	300	300	300	350	350	350	400	400	400	400	400
		B(inch)	12	12	12	14	14	14	16	16	16	16	16
Fuel (Gas)	Nozzle size	A(mm)	50 (at 4,000mAq)					65 (at 4,000mAq)					
		B(inch)	2 (at 4,000mAq)					2 1/2 (at 4,000mAq)					
	Cooling	Nm ³ /h	161.7	181.9	202.1	231	259.9	288.7	317.6	346.5	375.4	404.2	433.1
	Heating	Nm ³ /h	161.7	181.9	202.1	231	259.9	288.7	317.6	346.5	375.4	404.2	433.1
Electrical data	Source	V	3ø 220/380/440V, 50Hz/60Hz										
	Total current	A	35.7	35.7	35.7	44.4	49.4	49.4	73.7	73.7	73.7	73.7	73.7
	Wire size	mm ²	16	16	16	16	25	25	35	35	35	35	35
	Power	kVA	23.5	23.5	23.5	29.2	32.5	32.5	48.5	48.5	48.5	48.5	48.5
	Absorbent pump no.1	kW(A)	6.6(16.2)	6.6(16.2)	6.6(16.2)	5.5(20.0)	7.5(25.0)	7.5(25.0)	7.5(25.0)	7.5(25.0)	7.5(25.0)	7.5(25.0)	7.5(25.0)
	Absorbent pump no.2	kW(A)	2.0(5.2)	2.0(5.2)	2.0(5.2)	2.2(6.7)	2.2(6.7)	2.2(6.7)	5.5(21.0)	5.5(21.0)	5.5(21.0)	5.5(21.0)	5.5(21.0)
	Refrigerant pump	kW(A)	0.4(1.4)	0.4(1.4)	0.4(1.4)	0.4(1.4)	0.4(1.4)	0.4(1.4)	1.5(3.9)	1.5(3.9)	1.5(3.9)	1.5(3.9)	1.5(3.9)
	Purge pump	kW(A)	0.4(1.45)	0.4(1.45)	0.4(1.45)	0.4(1.45)	0.4(1.45)	0.4(1.45)	0.75(2.5)	0.75(2.5)	0.75(2.5)	0.75(2.5)	0.75(2.5)
	Burner blower (gas)	kW(A)	5.5(10.6)	5.5(10.6)	5.5(10.6)	7.5(14.0)	7.5(14.0)	7.5(14.0)	11.0(20.5)	11.0(20.5)	11.0(20.5)	11.0(20.5)	11.0(20.5)
Dimension	Length	mm	5,060	5,600	6,100	5,740	6,240	6,760	6,170	6,690	7,190	6,850	7,350
	Width	mm	3,080	3,080	3,080	3,400	3,400	3,400	4,180	4,180	4,180	4,590	4,590
	Height	mm	3,066	3,066	3,066	3,600	3,600	3,600	3,600	3,600	3,600	3,800	3,800
Rigging	Operating	ton	21.2	22.9	24.7	33.5	36.1	38.9	44.3	47.6	50.6	55.5	58.5
	Total shipping	ton	19.1	20.6	22.1	29.4	31.8	34.3	39.8	42.8	45.5	50.0	52.6
	Flue Connection Size	ton	15.7	16.6	17.8	23.7	25.5	27.4	31.4	33.6	35.5	38.8	40.6
Flue connection size	mm	500 x 350	500 x 350	500 x 350	620 x 400	620 x 400	620 x 400	900 x 400	900 x 400	900 x 400	900 x 400	900 x 400	
Clearance for tube removal	mm	4,600	5,200	5,700	5,200	5,700	6,200	5,700	6,200	6,700	6,200	6,700	

Note:

1. 1usRT = 3,024kcal/h, 1kW = 860kcal/h
2. Standard Tube and Water Side Pressure(Chiller & Cooling Water Circuit): 8kg/cm²G(785kPa)
3. Standard gas pressure : 4,000mmAq
4. Standard low calorific value : 9,360 kcal/Nm³
5. Currents & Electricity Consumptions are based on 3ø 380V 60Hz
6. Power supply wire size is based on the due of metal conduit and 40 °C of ambient temperature.
7. The specifications are subject to change without prior notice.
8. Fouling factor of water side: 0.0001 m² hr C/kcal

WCDA Series

Model name			005	006	007	008
Cooling capacity	USRT		50	60	70	80
	kW		176	211	246	281
Heating capacity	10 ³ kcal/h		182	218	254	291
	kW		212	253	295	338
Chilled water data	Temperature	°C	12 → 7.0			
	Water flow rate	m ³ /h	30.3	36.3	42.4	48.4
	Pressure drop	mAq	3	3.3	2.4	2.5
	Connection size	A(mm)	80	80	80	80
		B(inch)	3	3	3	3
Hot water data	Temperature	°C	54.0 → 60.0			
	Water flow rate	m ³ /h	30.3	36.3	42.4	48.4
	Pressure drop	mAq	3	3.3	2.4	2.5
	Connection size	A(mm)	80	80	80	80
		B(inch)	3	3	3	3
Cooling water data	Temperature	°C	32.0 → 37.6			
	Water flow rate	m ³ /h	50	60	70	80
	Pressure drop	mAq	4.4	5.2	3.9	4.2
	Connection size	A(mm)	100	100	100	100
		B(inch)	4	4	4	4
Fuel (Gas)	Nozzle size	A(mm)	25 (at 200mmAq)		40 (at 200mmAq)	
		B(inch)	1 (at 200mmAq)		1 1/2 (at 200mmAq)	
	Cooling	Nm ³ /h	15.3	18.4	21.5	24.5
	Heating	Nm ³ /h	21.1	25.3	29.5	33.7
Electrical data	Source	V	3ø 220/380/440V, 50Hz/60Hz			
	Total current	A	8.2	8.2	9.5	9.5
	Wire size	mm ²	4	4	4	4
	Power	kVA	5.4	5.4	6.2	6.2
	Absorbent Pump	kW(A)	1.2(4.1)	1.2(4.1)	1.2(4.1)	1.2(4.1)
	Refrigerant Pump	kW(A)	0.2(1.1)	0.2(1.1)	0.2(1.1)	0.2(1.1)
	Purge pump	kW(A)	0.4(1.45)	0.4(1.45)	0.4(1.45)	0.4(1.45)
	Burner blower (gas)	kW(A)	0.37(1.0)	0.37(1.0)	0.74(2.3)	0.74(2.3)
Dimension	Length	mm	1,976	1,976	2,480	2,480
	Width	mm	1,875	1,875	1,875	1,875
	Height	mm	1,852	1,852	1,852	1,852
Rigging	Operating	ton	3.2	3.4	3.8	4.0
	Total shipping	ton	2.9	3.1	3.5	3.7
	Max Shipping	ton	2.3	2.5	2.7	2.9
Flue connection size	mm	190 x 100	190 x 100	270 x 150	270 x 150	
Clearance for tube removal	mm	1,700	1,700	2,200	2,200	

Note:

- 1 usRT = 3,024kcal/h, 1kW = 860kcal/h
2. Standard Tube and Water Side Pressure(Chiller & Cooling Water Circuit): 5kg/cm²G(490kPa)
3. Standard gas pressure : 4,000mmAq
4. Standard low calorific value : 9,360 kcal/N m³
5. Currents & Electricity Consumptions are based on 3ø 380V 60Hz
6. Power supply wire size is based on the due of metal conduit and 40 °C of ambient temperature.
7. The specifications are subject to change without prior notice.
8. Fouling factor of water side: 0.0001 m² hr C/kcal

WCSH Series

Model name		010	012	015	018	021	024	028	032	036	040	045	050	
Cooling capacity	USRT	100	120	150	180	210	240	280	320	360	400	450	500	
	kW	352	422	528	633	739	844	985	1,125	1,266	1,407	1,583	1,758	
Chilled water data	Temperature	°C 12 → 7.0												
	Water flow rate	m ³ /h	60.5	72.6	90.7	108.9	127	145.2	169.3	193.5	217.7	241.9	272.2	302.4
	Pressure drop	mAq	6.2	6.3	8.0	8.3	8.0	8.1	5.4	5.5	5.6	5.8	5.1	5.2
	Connection size	A(mm)	100	100	100	100	125	125	150	150	150	150	200	200
		B(inch)	4	4	4	4	5	5	6	6	6	6	8	8
Hot water data	Temperature	°C 32.0 → 37.0												
	Water flow rate	m ³ /h	100	120	150	180	210	240	280	320	360	400	450	500
	Pressure drop	mAq	3.9	4.2	6.1	6.9	6.1	6.6	8.3	8.8	7.4	8.0	8.8	9.7
	Connection size	A(mm)	125	125	125	125	150	150	200	200	200	200	250	250
		B(inch)	5	5	5	5	6	6	8	8	8	8	10	10
Fuel	Steam Flow rate	kg/h	350	420	525	630	735	840	980	1,120	1,260	1,400	1,575	1,750
	Steam Inlet Connection	A(mm)	50	50	50	50	50	50	65	65	80	80	80	80
		B(inch)	2	2	2	2	2	2	2.5	2.5	3	3	3	3
	Drain Outlet Connection	A(mm)	25	25	25	25	25	25	25	25	40	40	40	40
		B(inch)	1	1	1	1	1	1	1	1	1.5	1.5	1.5	1.5
	Steam Control Valve	A(mm)	25	25	40	40	40	40	40	50	50	50	50	50
B(inch)		1	1	1.5	1.5	1.5	1.5	1.5	2	2	2	2	2	
Electrical data	Source	V	3ø 220/380/440V, 50Hz/60Hz											
	Total current	A	10.1	10.1	13.5	13.5	13.5	13.5	19.2	19.2	19.2	19.2	18.9	18.9
	Wire size	mm ²	4	4	4	4	4	4	6	6	10	10	10	10
	Power	kVA	6.6	6.6	8.9	8.9	8.9	8.9	12.6	12.6	12.6	12.6	12.4	12.4
	Absorbent pump no.1	kW(A)	1.5(5.43)	1.5(5.43)	2.4(6.4)	2.4(6.4)	2.4(6.4)	2.4(6.4)	3.4(10.3)	3.4(10.3)	3.4(10.3)	3.4(10.3)	3.4(10.3)	3.4(10.3)
	Absorbent pump no.2	kW(A)	0.4(1.6)	0.4(1.6)	1.2(4.0)	1.2(4.0)	1.2(4.0)	1.2(4.0)	1.5(5.5)	1.5(5.5)	1.5(5.5)	1.5(5.5)	2.0(5.2)	2.0(5.2)
	Refrigerant pump	kW(A)	0.2(1.1)	0.2(1.1)	0.2(1.1)	0.2(1.1)	0.2(1.1)	0.2(1.1)	0.4(1.4)	0.4(1.4)	0.4(1.4)	0.4(1.4)	0.4(1.4)	0.4(1.4)
	Purge pump	kW(A)	0.4(1.45)	0.4(1.45)	0.4(1.45)	0.4(1.45)	0.4(1.45)	0.4(1.45)	0.4(1.45)	0.4(1.45)	0.4(1.45)	0.4(1.45)	0.4(1.45)	0.4(1.45)
Dimension	Length	mm	2,730	2,730	3,720	3,720	3,720	3,720	4,740	4,740	4,800	4,800	4,815	4,815
	Width	mm	1,810	1,810	1,810	1,810	2,000	2,000	2,070	2,070	2,200	2,200	2,385	2,385
	Height	mm	2,065	2,065	2,070	2,110	2,415	2,415	2,415	2,415	2,590	2,590	2,950	2,950
Rigging	Operating	ton	4.5	5.0	6.0	6.5	7.6	8.1	9.8	10.3	11.9	13.1	15.3	16.8
	Total shipping	ton	4.1	4.6	5.5	5.9	6.8	7.2	8.7	9.2	10.5	11.6	13.5	14.8
	Max Shipping	ton	3.5	3.9	4.6	4.9	5.7	5.9	7.1	7.6	8.6	9.6	11.3	12.5
Clearance for tube removal	mm	2,400	2,400	3,400	3,400	3,400	3,400	4,500	4,500	4,500	4,500	4,500	4,500	

Note:

1. 1usRT = 3,024kcal/h, 1kW = 860kcal/h
2. Standard Tube and Water Side Pressure(Chiller & Cooling Water Circuit): 10kg/cm²G(981kPa)
3. Currents & Electricity Consumptions are based on 3ø 380V 60Hz
4. Alternate cooling water temperature range available upon request.
5. Power supply wire size is based on the due of metal conduit and 40°C of ambient temperature.
6. The specifications are subject to change without prior notice.
7. Fouling factor of water side: 0.0001 m² hr C/kcal

WCSH Series

Model name		056	063	070	080	090	100S	110	120	130	140	150	
Cooling capacity	USRT	560	630	700	800	900	1000	1100	1200	1300	1400	1500	
	kW	1,969	2,216	2,462	2,813	3,165	3,517	3,869	4,220	4,572	4,924	5,275	
Chilled water data	Temperature	°C 12 → 7.0											
	Water flow rate	m ³ /h	338.7	381	423.4	483.8	544.3	604.8	665.3	725.8	786.2	846.7	907.2
	Pressure drop	mAq	5.2	7.2	9.6	4.4	6.0	7.9	5.8	6.1	9.2	7.6	9.3
	Connection size	A(mm)	200	200	200	250	250	250	300	300	300	350	350
		B(inch)	8	8	8	10	10	10	12	12	12	14	14
Hot water data	Temperature	°C 32.0 → 37.0											
	Water flow rate	m ³ /h	560	630	700	800	900	1,000	1,100	1,200	1,300	1,400	1,500
	Pressure drop	mAq	8.9	11.9	15.3	6.9	9.3	12.3	9.2	11.7	14.6	11.4	13.9
	Connection size	A(mm)	300	300	300	350	350	350	400	400	400	400	400
		B(inch)	12	12	12	14	14	14	16	16	16	16	16
Fuel (Gas)	Steam Flow rate	kg/h	1,960	2,205	2,450	2,800	3,150	3,500	3,850	4,200	4,550	4,900	5,250
	Steam Inlet Connection	A(mm)	100	100	100	125	125	125	150	150	150	150	150
		B(inch)	4	4	4	5	5	5	6	6	6	6	6
	Drain Outlet Connection	A(mm)	50	50	50	65	65	65	80	80	80	80	80
		B(inch)	2	2	2	2.5	2.5	2.5	3	3	3	3	3
	Steam Control Valve	A(mm)	65	65	65	65	80	80	80	80	80	100	100
B(inch)		2.5	2.5	2.5	2.5	3	3	3	3	3	4	4	
Electrical data	Source	V	3ø 220/380/440V, 50Hz/60Hz										
	Total current	A	25.1	25.1	25.1	26.6	35.4	35.4	53.2	53.2	53.2	53.2	53.2
	Wire size	mm ²	16	16	16	16	25	35	35	35	35	35	35
	Power	kVA	16.5	16.5	16.5	17.5	23.3	23.3	35.0	35.0	35.0	35.0	35.0
	Absorbent pump no.1	kW(A)	6.6(16.2)	6.6(16.2)	6.6(16.2)	6.6(16.2)	7.5(25.0)	7.5(25.0)	7.5(25.0)	7.5(25.0)	7.5(25.0)	7.5(25.0)	7.5(25.0)
	Absorbent pump no.2	kW(A)	2.0(5.2)	2.0(5.2)	2.0(5.2)	2.2(6.7)	2.2(6.7)	2.2(6.7)	5.5(21.0)	5.5(21.0)	5.5(21.0)	5.5(21.0)	5.5(21.0)
	Refrigerant pump	kW(A)	0.4(1.4)	0.4(1.4)	0.4(1.4)	0.4(1.4)	0.4(1.4)	0.4(1.4)	1.5(3.9)	1.5(3.9)	1.5(3.9)	1.5(3.9)	1.5(3.9)
	Purge pump	kW(A)	0.4(1.45)	0.4(1.45)	0.4(1.45)	0.4(1.45)	0.4(1.45)	0.4(1.45)	0.75(2.5)	0.75(2.5)	0.75(2.5)	0.75(2.5)	0.75(2.5)
Dimension	Length	mm	5,030	5,520	6,010	5,635	6,130	6,590	6,060	6,580	7,080	6,640	7,140
	Width	mm	2,620	2,620	2,620	3,090	3,090	3,090	3,180	3,180	3,180	3,520	3,520
	Height	mm	3,300	3,300	3,300	3,550	3,550	3,550	3,820	3,820	3,820	3,840	3,840
Rigging	Operating	ton	20.2	23.8	26.8	30.9	32.9	35.8	38.8	42.2	45.8	49.4	52.8
	Total shipping	ton	17.4	20.7	23.5	26.6	28.3	30.9	33.9	36.9	40.2	43.2	46.3
	Max Shipping	ton	14.8	17.6	19.9	21.3	22.7	24.1	26.0	27.8	29.7	31.5	33.4
Clearance for tube removal	mm	4,500	5,200	5,700	5,200	5,700	6,200	5,700	6,200	6,700	6,200	6,700	

Note:

1. 1usRT = 3,024kcal/h, 1kW = 860kcal/h
2. Standard Tube and Water Side Pressure(Chiller & Cooling Water Circuit): 10kg/cm²G(981kPa)
3. Currents & Electricity Consumptions are based on 3ø 380V 60Hz
4. Alternate cooling water temperature range available upon request.
5. Power supply wire size is based on the due of metal conduit and 40°C of ambient temperature.
6. The specifications are subject to change without prior notice.
7. Fouling factor of water side: 0.0001 m² hr C/kcal

WCSS Series

Model name		010	012	015	018	021	024	028	032	036	040	045	050	
Cooling capacity	USRT	100	120	150	180	210	240	280	320	360	400	450	500	
	kW	352	422	527	633	738	844	985	1,125	1,266	1,407	1,582	1,758	
Chilled water data	Temperature	°C 12 → 7.0												
	Water flow rate	m ³ /h	60.5	72.6	90.7	108.9	127	145.2	169.3	193.5	217.7	241.9	272.2	302.4
	Pressure drop	mAq	6.5	6.4	8.0	8.3	7.5	7.9	5.1	5.5	5.8	6.1	5.2	5.5
	Connection size	A(mm)	100	100	100	100	125	125	150	150	150	150	200	200
		B(inch)	4	4	4	4	5	5	6	6	6	6	8	8
Hot water data	Temperature	°C 32.0 → 37.5												
	Water flow rate	m ³ /h	100	120	150	180	210	240	280	320	360	400	450	500
	Pressure drop	mAq	3.9	4.4	6.5	7.7	5.6	6.2	10.9	12.1	8.7	9.4	10.3	11.2
	Connection size	A(mm)	125	125	125	125	150	150	200	200	200	200	250	250
		B(inch)	5	5	5	5	6	6	8	8	8	8	10	10
Fuel	Steam Flow rate	kg/h	440	528	660	792	924	1,060	1,230	1,410	1,580	1,760	1,980	2,200
	Steam Inlet Connection	A(mm)	50	50	50	50	65	65	65	65	80	80	80	80
		B(inch)	2	2	2	2	2 1/2	2 1/2	2 1/2	2 1/2	3	3	3	3
	Drain Outlet Connection	A(mm)	25	25	25	25	25	25	25	25	40	40	40	40
		B(inch)	1	1	1	1	1	1	1	1	1 1/2	1 1/2	1 1/2	1 1/2
	Steam Control Valve	A(mm)	25	40	40	40	40	40	50	50	50	50	65	65
B(inch)		1	1 1/2	1 1/2	1 1/2	1 1/2	1 1/2	2	2	2	2	2 1/2	2 1/2	
Electrical data	Source	V	3ø 220/380/440V, 50Hz/60Hz											
	Total current	A	8.5	8.5	9.5	9.5	9.5	9.5	19.2	19.2	19.2	19.2	20.6	20.6
	Wire size	mm ²	4	4	4	4	4	4	4	4	4	4	4	4
	Power	kVA	5.6	5.6	6.3	6.3	6.3	6.3	12.6	12.6	12.6	12.6	13.6	13.6
	Absorbent pump no.1	kW(A)	1.5(5.43)	1.5(5.43)	2.4(6.4)	2.4(6.4)	2.4(6.4)	2.4(6.4)	3.4(10.3)	3.4(10.3)	3.4(10.3)	3.4(10.3)	3.7(12.0)	3.7(12.0)
	Absorbent pump no.2	kW(A)	n/a	n/a	n/a	n/a	n/a	n/a	1.5(5.5)	1.5(5.5)	1.5(5.5)	1.5(5.5)	2.0(5.2)	2.0(5.2)
	Refrigerant pump	kW(A)	0.2(1.1)	0.2(1.1)	0.2(1.1)	0.2(1.1)	0.2(1.1)	0.2(1.1)	0.4(1.4)	0.4(1.4)	0.4(1.4)	0.4(1.4)	0.4(1.4)	0.4(1.4)
	Purge pump	kW(A)	0.4(1.45)	0.4(1.45)	0.4(1.45)	0.4(1.45)	0.4(1.45)	0.4(1.45)	0.4(1.45)	0.4(1.45)	0.4(1.45)	0.4(1.45)	0.4(1.45)	0.4(1.45)
Dimension	Length	mm	2,650	2,650	3,670	3,670	3,730	3,730	4,750	4,750	4,850	4,850	4,850	4,850
	Width	mm	1,800	1,800	1,800	1,800	2,030	2,030	2,030	2,030	2,110	2,110	2,350	2,350
	Height	mm	2,150	2,150	2,150	2,150	2,450	2,450	2,450	2,450	2,650	2,650	2,900	2,900
Rigging	Operating	ton	4.6	4.8	6.0	6.2	7.4	7.8	9.0	9.6	11.6	12.0	14.2	14.8
	Total shipping	ton	4.0	4.2	5.3	5.6	6.5	6.7	8.0	8.3	10.1	10.5	12.4	12.8
	Max Shipping	ton	3.2	3.3	4.1	4.2	5.0	5.1	6.0	6.2	7.6	7.9	9.3	9.5
Clearance for tube removal	mm	2,400	2,400	3,400	3,400	3,400	3,400	4,500	4,500	4,500	4,500	4,500	4,500	

Note:

1. 1usRT = 3,024kcal/h, 1kW = 860kcal/h
2. Standard Tube and Water Side Pressure(Chiller & Cooling Water Circuit): 10kg/cm²G(981kPa)
3. Currents & Electricity Consumptions are based on 3ø 380V 60Hz
4. Alternate cooling water temperature range available upon request.
5. Power supply wire size is based on the due of metal conduit and 40°C of ambient temperature.
6. The specifications are subject to change without prior notice.
7. Fouling factor of water side: 0.0001 m² hr C/kcal

WCSS Series

Model name		056	063	070	080	090	100S	110	120	130	140	150	
Cooling capacity	USRT	560	630	700	800	900	1,000	1,100	1,120	1,300	1,400	1,500	
	kW	1,969	2,215	2,461	2,813	3,165	3,516	3,868	3,938	4,571	4,923	5,274	
Chilled water data	Temperature	°C 12 → 7.0											
	Water flow rate	m ³ /h	338.7	381.0	423.4	483.8	544.3	604.8	665.3	725.8	786.2	846.7	907.2
	Pressure drop	mAq	5.2	7.1	9.4	4.7	6.4	8.4	6.2	7.9	9.8	8.0	9.8
	Connection size	A(mm)	200	200	200	250	250	250	300	300	300	350	350
		B(inch)	8	8	8	10	10	10	12	12	12	14	14
Hot water data	Temperature	°C 32.0 → 37.5											
	Water flow rate	m ³ /h	560	630	700	800	900	1,000	1,100	1,200	1,300	1,400	1,500
	Pressure drop	mAq	8.0	10.6	13.7	8.4	11.1	14.3	8.8	10.9	13.4	12.3	14.6
	Connection size	A(mm)	300	300	300	350	350	350	400	400	400	400	400
		B(inch)	12	12	12	14	14	14	16	16	16	16	16
Fuel (Gas)	Steam Flow rate	kg/h	2,470	2,780	3,080	3,520	3,960	4,400	4,840	5,280	5,720	6,160	6,600
	Steam Inlet Connection	A(mm)	100	100	100	125	125	125	150	150	150	150	150
		B(inch)	4	4	4	5	5	5	6	6	6	6	6
	Drain Outlet Connection	A(mm)	50	50	50	65	65	65	80	80	80	80	80
		B(inch)	2	2	2	2 1/2	2 1/2	2 1/2	3	3	3	3	3
	Steam Control Valve	A(mm)	65	65	80	80	80	80	100	100	100	100	100
B(inch)		2 1/2	2 1/2	3	3	3	3	4	4	4	4	4	
Electrical data	Source	V	3ø 220/380/440V, 50Hz/60Hz										
	Total current	A	25.1	25.1	25.1	26.6	35.4	35.4	53.2	53.2	53.2	53.2	53.2
	Wire size	mm ²	6	6	6	10	16	16	25	25	25	25	25
	Power	kVA	16.5	16.5	16.5	17.5	23.3	23.3	35.0	35.0	35.0	35.0	35.0
	Absorbent pump no.1	kW(A)	6.6(16.2)	6.6(16.2)	6.6(16.2)	6.6(16.2)	7.5(25.0)	7.5(25.0)	7.5(25.0)	7.5(25.0)	7.5(25.0)	7.5(25.0)	7.5(25.0)
	Absorbent pump no.2	kW(A)	2.0(5.2)	2.0(5.2)	2.0(5.2)	2.2(6.7)	2.2(6.7)	2.2(6.7)	5.5(21.0)	5.5(21.0)	5.5(21.0)	5.5(21.0)	5.5(21.0)
	Refrigerant pump	kW(A)	0.4(1.4)	0.4(1.4)	0.4(1.4)	0.4(1.4)	0.4(1.4)	0.4(1.4)	1.5(3.9)	1.5(3.9)	1.5(3.9)	1.5(3.9)	1.5(3.9)
	Purge pump	kW(A)	0.4(1.45)	0.4(1.45)	0.4(1.45)	0.4(1.45)	0.4(1.45)	0.4(1.45)	0.75(2.5)	0.75(2.5)	0.75(2.5)	0.75(2.5)	0.75(2.5)
Dimension	Length	mm	5,060	5,600	6,100	5,710	6,210	6,730	6,170	6,690	7,180	6,830	7,330
	Width	mm	2,500	2,500	2,500	2,850	2,850	2,850	3,000	3,000	3,000	3,500	3,500
	Height	mm	3,255	3,255	3,255	3,580	3,580	3,580	3,750	3,750	3,750	3,950	3,950
Rigging	Operating	ton	19.6	21.4	23.0	29.4	31.6	34.0	37.8	40.4	42.8	47.2	50.0
	Total shipping	ton	16.9	18.5	19.8	25.4	27.3	29.3	33.2	35.5	37.7	41.7	44.0
	Max Shipping	ton	13.3	14.3	15.3	19.7	21.0	22.4	24.8	26.3	27.7	30.5	32.1
Clearance for tube removal	mm	4,600	5,200	5,700	5,200	5,700	6,200	5,800	6,300	6,800	6,300	6,800	

Note:

- 1 usRT = 3,024kcal/h, 1kW = 860kcal/h
2. Standard Tube and Water Side Pressure(Chiller & Cooling Water Circuit): 10kg/cm²G(981kPa)
3. Currents & Electricity Consumptions are based on 3ø 380V 60Hz
4. Alternate cooling water temperature range available upon request.
5. Power supply wire size is based on the due of metal conduit and 40°C of ambient temperature.
6. The specifications are subject to change without prior notice.
7. Fouling factor of water side: 0.0001 m² hr C/kcal

WCMH Series

Model name			008	009	011	014	016	018	021
Cooling capacity	USRT		75	90	110	135	155	180	210
	kW		264	316	387	475	545	633	738
Chilled water data	Temperature	°C	13.0 → 8.0						
	Water flow rate	m ³ /h	45.4	54.4	66.5	81.6	93.7	108.9	127.0
	Pressure drop	mAq	6.8	7.0	5.8	6.0	6.2	6.5	8.6
	Connection size	A(mm)	80	80	100	100	125	125	125
		B(inch)	3	3	4	4	5	5	5
Cooling Water Data	Temperature	°C	31.0 → 36.5						
	Water flow rate	m ³ /h	92.1	110.6	135.1	165.9	190.4	221.1	258.0
	Pressure drop	mAq	5.4	5.9	5.7	6.2	4.7	5.4	7.7
	Connection size	A(mm)	125	125	150	150	150	150	200
		B(inch)	5	5	6	6	6	6	8
Fuel	Temperature	°C	95.0 → 72.0						
	Water Flow rate	ton/h	12.2	14.6	17.9	21.9	25.2	29.2	34.1
	Pressure Drop	mAq	0.9	1.0	2.3	2.4	2.4	2.6	4.8
	Connection size	A(mm)	65	65	65	65	80	80	80
		B(inch)	2 1/2	2 1/2	2 1/2	2 1/2	3	3	3
	Connection size of Control valve	A(mm)	40	40	50	50	65	65	80
B(inch)		1 1/2	1 1/2	2	2	2 1/2	2 1/2	3	
Electrical data	Source	V	3ø 220/380/440V, 50Hz/60Hz						
	Total current	A	8.3	8.3	8.3	8.3	8.3	8.3	8.6
	Wire size	mm ²	4	4	4	4	4	4	4
	Power	kVA	5.4	5.4	5.4	5.4	5.4	5.4	5.7
	Absorbent pump no.1	kW	20	20	20	20	20	20	20
		A	52	52	52	52	52	52	52
	Absorbent pump no.2	kW	N/A	N/A	N/A	N/A	N/A	N/A	1.5
		A	N/A	N/A	N/A	N/A	N/A	N/A	5.5
	Refrigerant pump	kW	0.2	0.2	0.2	0.2	0.2	0.2	0.4
		A	1.1	1.1	1.1	1.1	1.1	1.1	1.4
	Purge pump	kW	0.4	0.4	0.4	0.4	0.4	0.4	0.4
A		1.45	1.45	1.45	1.45	1.45	1.45	1.45	
Dimension	Length	mm	2,747	2,747	3,767	3,767	3,827	3,827	4,732
	Width	mm	1,355	1,355	1,355	1,355	1,526	1,526	2,265
	Height	mm	2,150	2,150	2,150	2,150	2,330	2,330	2,090
Rigging	Operating	ton	4.9	5.2	6.4	6.8	8.3	8.6	10.1
	Total shipping	ton	3.6	3.7	4.6	4.9	5.8	6.0	6.8
	Max Shipping	ton	4.2	4.4	5.5	5.9	7.1	7.3	8.5
Clearance for tube removal	mm	2,400	2,400	3,400	3,400	3,400	3,400	4,500	

Note:

1. 1usRT = 3,024kcal/h, 1kW = 860kcal/h
2. Standard Tube and Water Side Pressure(Chiller & Cooling Water Circuit): 10kg/cm²G(981kPa)
3. Currents & Electricity Consumptions are based on 3ø 380V 60Hz
4. Alternate cooling water temperature range available upon request.
5. Power supply wire size is based on the due of metal conduit and 40 °C of ambient temperature.
6. The specifications are subject to change without prior notice.
7. Fouling factor of water side: 0.0001 m² hr C/kcal

WCMH Series

Model name			024	027	030	034	038	042
Cooling capacity	USRT		240	270	300	340	375	420
	kW		844	949	1,055	1,196	1,319	1,477
Chilled water data	Temperature	°C	13.0 → 8.0					
	Water flow rate	m ³ /h	145.2	163.3	181.4	205.6	226.8	254.0
	Pressure drop	mAq	8.8	8.8	8.9	9.4	9.7	6.5
	Connection size	A(mm)	125	150	150	200	200	200
		B(inch)	5	6	6	8	8	8
Cooling Water Data	Temperature	°C	31.0 → 36.5					
	Water flow rate	m ³ /h	294.9	331.7	368.6	417.7	460.7	516.0
	Pressure drop	mAq	8.4	7.4	8.1	7.9	8.6	7.3
	Connection size	A(mm)	200	250	250	250	250	300
		B(inch)	8	10	10	10	10	12
Fuel	Temperature	°C	95.0 → 72.0					
	Water Flow rate	ton/h	39.0	43.8	48.7	55.2	60.9	68.2
	Pressure Drop	mAq	4.7	4.8	4.8	4.8	4.8	2.2
	Connection size	A(mm)	80	80	80	100	100	100
		B(inch)	3	3	3	4	4	4
	Connection size of Control valve	A(mm)	80	80	80	100	100	100
		B(inch)	3	3	3	4	4	4
Electrical data	Source	V	3ø 220/380/440V, 50Hz/60Hz					
	Total current	A	8.9	8.9	8.9	8.9	8.9	19.9
	Wire size	mm ²	4	4	4	4	4	6
	Power	kVA	5.8	5.8	5.8	5.8	5.8	13.1
	Absorbent pump no.1	kW	2.2	2.2	2.2	2.2	2.2	3.0
		A	5.5	5.5	5.5	5.5	5.5	11.0
	Absorbent pump no.2	kW	1.5	1.5	1.5	2.0	2.0	2.0
		A	5.5	5.5	5.5	5.2	5.2	5.2
	Refrigerant pump	kW	0.4	0.4	0.4	0.4	0.4	0.4
		A	1.4	1.4	1.4	1.4	1.4	1.4
	Purge pump	kW	0.4	0.4	0.4	0.4	0.4	0.4
A		1.45	1.45	1.45	1.45	1.45	1.45	
Dimension	Length	mm	4,732	4,850	4,850	4,910	4,910	4,995
	Width	mm	2,265	2,380	2,380	2,550	2,550	2,745
	Height	mm	2,090	2,340	2,340	2,615	2,615	2,940
Rigging	Operating	ton	10.7	13.0	13.6	16.1	16.8	23.2
	Total shipping	ton	7.2	8.9	9.2	10.9	11.4	16.1
	Max Shipping	ton	9.0	10.9	11.4	13.4	14.0	19.4
Clearance for tube removal	mm	4,500	4,500	4,500	4,500	4,500	4,600	

Note:

- 1 usRT = 3,024kcal/h, 1kW = 860kcal/h
2. Standard Tube and Water Side Pressure(Chiller & Cooling Water Circuit): 10kg/cm²G(981kPa)
3. Currents & Electricity Consumptions are based on 3ø 380V 60Hz
4. Alternate cooling water temperature range available upon request.
5. Power supply wire size is based on the due of metal conduit and 40°C of ambient temperature.
6. The specifications are subject to change without prior notice.
7. Fouling factor of water side: 0.0001 m² hr C/kcal

WCMH Series

Model name			047	053	060	068	075	083
Cooling capacity	USRT		470	525	600	675	750	825
	kW		1,653	1,846	2,110	2,373	2,637	2,901
Chilled water data	Temperature	°C	13.0 → 8.0					
	Water flow rate	m ³ /h	284.3	317.5	362.9	408.2	453.6	499.0
	Pressure drop	mAq	8.4	10.6	7.0	8.7	11.3	6.8
	Connection size	A(mm)	200	200	250	250	250	300
		B(inch)	8	8	10	10	10	12
Cooling Water Data	Temperature	°C	31.0 → 36.5					
	Water flow rate	m ³ /h	577.4	645.0	737.2	829.3	921.5	1013.6
	Pressure drop	mAq	9.2	10.7	6.8	9.3	12.2	7.2
	Connection size	A(mm)	300	300	350	350	350	400
		B(inch)	12	12	14	14	14	16
Fuel	Temperature	°C	95.0 → 72.0					
	Water Flow rate	ton/h	76.3	85.2	97.4	109.6	121.7	133.9
	Pressure Drop	mAq	3.0	4.0	2.8	3.7	4.9	1.4
	Connection size	A(mm)	100	100	125	125	125	150
		B(inch)	4	4	5	5	5	6
	Connection size of Control valve	A(mm)	100	125	125	125	125	150
		B(inch)	4	5	5	5	5	6
Electrical data	Source	V	3ø 220/380/440V, 50Hz/60Hz					
	Total current	A	19.9	21.4	21.4	21.4	26.4	44.2
	Wire size	mm ²	6	6	6	6	10	16
	Power	kVA	13.1	14.1	14.1	14.1	17.3	29.1
	Absorbent pump no.1	kW	3.0	3.0	3.0	3.0	4.5	4.5
		A	11.0	11.0	11.0	11.0	16.0	16.0
	Absorbent pump no.2	kW	2.0	2.2	2.2	2.2	2.2	5.5
		A	5.2	6.7	6.7	6.7	6.7	21.0
	Refrigerant pump	kW	0.4	0.4	0.4	0.4	0.4	1.5
		A	1.4	1.4	1.4	1.4	1.4	3.9
	Purge pump	kW	0.4	0.4	0.4	0.4	0.4	0.75
A		1.45	1.45	1.45	1.45	1.45	2.5	
Dimension	Length	mm	5,540	6,035	5,680	6,180	6,705	6,340
	Width	mm	2,745	2,745	3,235	3,235	3,235	3,800
	Height	mm	2,940	2,940	3,175	3,175	3,175	3,650
Rigging	Operating	ton	25.1	26.4	33.0	35.4	38.0	42.8
	Total shipping	ton	17.4	18.1	22.0	23.6	25.4	28.6
	Max Shipping	ton	21.1	22.2	27.2	29.3	31.7	36.1
Clearance for tube removal	mm	5,200	5,700	5,200	5,700	6,200	5,800	

Note:

1. 1usRT = 3,024kcal/h, 1kW = 860kcal/h
2. Standard Tube and Water Side Pressure(Chiller & Cooling Water Circuit): 10kg/cm²G(981kPa)
3. Currents & Electricity Consumptions are based on 3ø 380V 60Hz
4. Alternate cooling water temperature range available upon request.
5. Power supply wire size is based on the due of metal conduit and 40 °C of ambient temperature.
6. The specifications are subject to change without prior notice.
7. Fouling factor of water side: 0.0001 m² hr C/kcal

WCMH Series

Model name			090	098	105	113	120	135
Cooling capacity	USRT		900	975	1050	1125	1200	1350
	kW		3,165	3,428	3,692	3,956	4,220	4,747
Chilled water data	Temperature	°C	13.0 → 8.0					
	Water flow rate	m ³ /h	544.3	589.7	635.0	680.4	725.8	816.5
	Pressure drop	mAq	8.5	10.4	7.0	8.8	8.3	10.9
	Connection size	A(mm)	300	300	300	300	350	350
		B(inch)	12	12	12	12	14	14
Cooling Water Data	Temperature	°C	31.0 → 36.5					
	Water flow rate	m ³ /h	1105.7	1197.9	1290.0	1382.2	1474.3	1658.6
	Pressure drop	mAq	9.3	12.0	11.1	13.1	11.6	13.9
	Connection size	A(mm)	400	400	400	400	450	450
		B(inch)	16	16	16	16	18	18
Fuel	Temperature	°C	95.0 → 72.0					
	Water Flow rate	ton/h	146.1	158.3	170.4	182.6	194.8	219.1
	Pressure Drop	mAq	1.8	2.2	1.9	2.2	2.5	2.5
	Connection size	A(mm)	150	150	200	200	200	200
		B(inch)	6	6	8	8	8	8
	Connection size of Control valve	A(mm)	150	150	150	150	200	200
		B(inch)	6	6	6	6	8	8
Electrical data	Source	V	3ø 220/380/440V, 50Hz/60Hz					
	Total current	A	44.2	44.2	44.2	44.2	44.2	44.2
	Wire size	mm ²	16	16	16	16	16	16
	Power	kVA	29.1	29.1	29.1	29.1	29.1	29.1
	Absorbent pump no.1	kW	4.5	4.5	4.5	4.5	4.5	4.5
		A	16.0	16.0	16.0	16.0	16.0	16.0
	Absorbent pump no.2	kW	5.5	5.5	5.5	5.5	5.5	5.5
		A	21.0	21.0	21.0	21.0	21.0	21.0
	Refrigerant pump	kW	1.5	1.5	1.5	1.5	1.5	1.5
		A	3.9	3.9	3.9	3.9	3.9	3.9
	Purge pump	kW	0.75	0.75	0.75	0.75	0.75	0.75
A		2.5	2.5	2.5	2.5	2.5	2.5	
Dimension	Length	mm	6,865	7,365	7,070	7,570	7,570	8,070
	Width	mm	3,800	3,800	4,000	4,000	4,200	4,200
	Height	mm	3,650	3,650	3,750	3,750	3,850	3,850
Rigging	Operating	ton	45.8	48.6	54.0	56.9	62.9	66.5
	Total shipping	ton	30.5	32.3	35.5	37.3	37.3	37.3
	Max Shipping	ton	38.8	41.0	45.4	47.8	47.8	47.8
Clearance for tube removal	mm	6,300	6,800	6,300	6,800	6,800	7,400	

Note:

- 1 usRT = 3,024kcal/h, 1kW = 860kcal/h
2. Standard Tube and Water Side Pressure(Chiller & Cooling Water Circuit): 10kg/cm²G(981kPa)
3. Currents & Electricity Consumptions are based on 3ø 380V 60Hz
4. Alternate cooling water temperature range available upon request.
5. Power supply wire size is based on the due of metal conduit and 40°C of ambient temperature.
6. The specifications are subject to change without prior notice.
7. Fouling factor of water side: 0.0001 m² hr C/kcal

WCMW Series

Model name			003		004		005		007		008		010		012		
Cooling capacity		USRT	28	30	38	40	47	50	61	65	75	80	94	100	113	120	
		kW	98	105	134	141	165	176	214	229	264	281	331	352	397	422	
Chilled water data	Temperature	°C	12-7	13-8	12-7	13-8	12-7	13-8	12-7	13-8	12-7	13-8	12-7	13-8	12-7	13-8	
	Water flow rate	m ³ /h	17.1	18.1	22.8	24.2	28.5	30.2	37.0	39.3	45.6	48.4	57.0	60.5	68.3	72.6	
	Pressure drop	mAq	2.6	3.0	3.5	4.0	6.4	7.2	7.8	8.8	8.0	9.1	7.0	7.8	7.0	7.8	
	Connection size	A(mm)	65	65	65	65	65	65	65	80	80	80	80	100	100	100	100
		B(inch)	2 1/2	2 1/2	2 1/2	2 1/2	2 1/2	2 1/2	2 1/2	3	3	3	3	4	4	4	4
Cooling Water Data	Temperature	°C	31.0 → 36.5														
	Water flow rate	m ³ /h	37.4	39.4	49.8	52.5	62.3	65.7	81.0	85.4	99.7	105.1	124.6	131.3	149.5	157.6	
	Pressure drop	mAq	2.5	2.8	3.6	4.0	6.3	7.0	2.3	2.6	2.8	3.1	4.3	4.8	5.1	5.7	
	Connection size	A(mm)	80	80	80	80	80	80	125	125	125	125	125	125	125	125	125
		B(inch)	3	3	3	3	3	3	3	5	5	5	5	5	5	5	5
Fuel	Temperature	°C	95.0 → 80.0														
	Water Flow rate	ton/h	8.0	8.4	10.7	11.2	13.4	14.0	17.4	18.2	21.4	22.4	26.7	28.0	32.0	33.6	
	Pressure Drop	mAq	1.1	1.2	1.2	1.3	2.6	2.9	0.8	0.9	0.9	1.0	2.1	2.3	2.2	2.4	
	Connection size	A(mm)	40	40	40	40	65	65	65	65	65	65	80	80	80	80	
		B(inch)	1 1/2	1 1/2	1 1/2	1 1/2	2 1/2	2 1/2	2 1/2	2 1/2	2 1/2	2 1/2	3	3	3	3	
	Connection size of Control valve	A(mm)	40	40	40	40	40	40	50	50	65	65	65	65	80	80	
		B(inch)	1 1/2	1 1/2	1 1/2	1 1/2	1 1/2	1 1/2	2	2	2 1/2	2 1/2	2 1/2	2 1/2	3	3	
Electrical data	Source	V	3ø 220/380/440V, 50Hz/60Hz														
	Total current	A	7.2	7.2	7.2	7.2	7.2	7.2	8.3	8.3	8.3	8.3	8.3	8.3	8.3	8.3	
	Wire size	mm ²	4	4	4	4	4	4	4	4	4	4	4	4	4	4	
	Power	kVA	4.7	4.7	4.7	4.7	4.7	4.7	5.4	5.4	5.4	5.4	5.4	5.4	5.4	5.4	
	Absorbent pump no.1	kW(A)	1.2(4.1)	1.2(4.1)	1.2(4.1)	1.2(4.1)	1.2(4.1)	1.2(4.1)	2.0(5.2)	2.0(5.2)	2.0(5.2)	2.0(5.2)	2.0(5.2)	2.0(5.2)	2.0(5.2)	2.0(5.2)	
	Absorbent pump no.2	kW(A)	n/a	n/a	n/a	n/a	n/a	n/a	n/a	n/a	n/a	n/a	n/a	n/a	n/a	n/a	
	Refrigerant pump	kW(A)	0.2(1.1)	0.2(1.1)	0.2(1.1)	0.2(1.1)	0.2(1.1)	0.2(1.1)	0.2(1.1)	0.2(1.1)	0.2(1.1)	0.2(1.1)	0.2(1.1)	0.2(1.1)	0.2(1.1)	0.2(1.1)	
	Purge pump	kW(A)	0.4(1.45)	0.4(1.45)	0.4(1.45)	0.4(1.45)	0.4(1.45)	0.4(1.45)	0.4(1.45)	0.4(1.45)	0.4(1.45)	0.4(1.45)	0.4(1.45)	0.4(1.45)	0.4(1.45)	0.4(1.45)	
Dimension	Length	mm	2,020	2,020	2,020	2,020	2,520	2,520	2,547	2,547	2,547	2,547	3,567	3,567	3,567	3,567	
	Width	mm	1,394	1,394	1,396	1,396	1,396	1,396	1,355	1,355	1,355	1,355	1,355	1,355	1,355	1,355	
	Height	mm	1,952	1,952	1,965	1,965	1,965	1,965	2,150	2,150	2,150	2,150	2,150	2,150	2,150	2,150	
Rigging	Operating	ton	2.1	2.1	2.3	2.3	2.7	2.7	4.1	4.1	4.3	4.3	5.3	5.3	5.7	5.7	
	Total shipping	ton	1.7	1.7	1.8	1.8	2.2	2.2	3.5	3.5	3.7	3.7	4.6	4.6	4.9	4.9	
	Max Shipping	ton	1.3	1.3	1.4	1.4	1.6	1.6	3.0	3.0	3.1	3.1	3.8	3.8	4.1	4.1	
Clearance for tube removal		mm	2,000	2,000	2,000	2,000	2,400	2,400	2,400	2,400	2,400	2,400	3,400	3,400	3,400	3,400	

Note:

1. 1usRT = 3,024kcal/h, 1kW = 860kcal/h
2. Standard Tube and Water Side Pressure(Chiller & Cooling Water Circuit)
WCMW003-WCMW005 : 5kg/cm²G(490kPa)
WCMW003-WCMW005 : 8kg/cm²G(785kPa)
3. Currents & Electricity Consumptions are based on 3ø 380V 60Hz
4. Alternate cooling water temperature range available upon request.
5. Power supply wire size is based on the due of metal conduit and 40 °C of ambient temperature.
6. The specifications are subject to change without prior notice.
7. Fouling factor of water side: 0.0001 m² hr C/kcal

WCMW Series

Model name		014	016	019	021	024	027							
Cooling capacity	USRT	132	140	151	160	179	190	198	210	226	240	254	270	
	kW	464	492	531	563	629	668	696	738	795	844	893	949	
Chilled water data	Temperature	°C	12-7	13-8	12-7	13-8	12-7	13-8	12-7	13-8	12-7	13-8	12-7	13-8
	Water flow rate	m ³ /h	79.7	84.7	91.1	96.8	108.2	114.9	119.6	127.0	136.7	145.2	153.8	163.3
	Pressure drop	mAq	7.2	8.2	7.7	8.6	7.1	7.9	7.0	7.8	7.1	8.0	6.8	7.7
	Connection size	A(mm)	100	100	100	100	125	125	125	125	150	150	150	150
		B(inch)	4	4	4	4	5	5	5	5	6	6	6	6
Cooling Water Data	Temperature	°C	31.0 → 36.5											
	Water flow rate	m ³ /h	174.4	183.9	199.4	210.2	236.8	249.6	261.7	275.8	299.1	315.2	336.4	354.6
	Pressure drop	mAq	3.6	4.0	4.1	4.6	7.3	8.1	7.8	8.7	5.7	6.3	6.3	7.0
	Connection size	A(mm)	150	150	150	150	200	200	200	200	200	200	200	200
		B(inch)	6	6	6	6	8	8	8	8	8	8	8	8
Fuel	Temperature	°C	95.0 → 80.0											
	Water Flow rate	ton/h	37.4	39.2	42.7	44.8	50.7	53.2	56.1	58.8	64.1	67.2	72.1	75.6
	Pressure Drop	mAq	2.2	2.4	2.4	2.6	4.4	4.8	4.3	4.7	4.4	4.8	4.4	4.8
	Connection size	A(mm)	80	80	80	80	100	100	100	100	100	100	100	100
		B(inch)	3	3	3	3	4	4	4	4	4	4	4	4
	Connection size of Control valve	A(mm)	80	80	80	80	100	100	100	100	100	100	100	100
B(inch)		3	3	3	3	4	4	4	4	4	4	4	4	
Electrical data	Source	V	3ø 220/380/440V, 50Hz/60Hz											
	Total current	A	8.3	8.3	8.3	8.3	8.6	8.6	8.9	8.9	8.9	8.9	8.9	8.9
	Wire size	mm ²	4	4	4	4	4	4	4	4	4	4	4	4
	Power	kVA	5.4	5.4	5.4	5.4	5.7	5.7	5.8	5.8	5.8	5.8	5.8	5.8
	Absorbent pump no.1	kW(A)	2.0(5.2)	2.0(5.2)	2.0(5.2)	2.0(5.2)	2.0(5.2)	2.0(5.2)	2.2(5.5)	2.2(5.5)	2.2(5.5)	2.2(5.5)	2.2(5.5)	2.2(5.5)
	Absorbent pump no.2	kW(A)	n/a	n/a	n/a	n/a	n/a	n/a	n/a	n/a	n/a	n/a	n/a	n/a
	Refrigerant pump	kW(A)	0.2(1.1)	0.2(1.1)	0.2(1.1)	0.2(1.1)	0.4(1.4)	0.4(1.4)	0.4(1.4)	0.4(1.4)	0.4(1.4)	0.4(1.4)	0.4(1.4)	0.4(1.4)
	Purge pump	kW(A)	0.4(1.45)	0.4(1.45)	0.4(1.45)	0.4(1.45)	0.4(1.45)	0.4(1.45)	0.4(1.45)	0.4(1.45)	0.4(1.45)	0.4(1.45)	0.4(1.45)	0.4(1.45)
Dimension	Length	mm	3,627	3,627	3,627	3,627	4,630	4,630	4,630	4,630	4,784	4,784	4,784	4,784
	Width	mm	1,526	1,526	1,526	1,526	1,526	1,526	1,526	1,526	1,575	1,575	1,575	1,575
	Height	mm	2,330	2,330	2,330	2,330	2,330	2,330	2,330	2,330	2,630	2,630	2,630	2,630
Rigging	Operating	ton	6.9	6.9	7.2	7.2	8.4	8.4	8.9	8.9	10.8	10.8	11.3	11.3
	Total shipping	ton	5.8	5.8	6.1	6.1	7.1	7.1	7.5	7.5	9.1	9.1	9.5	9.5
	Max Shipping	ton	4.8	4.8	5.0	5.0	5.7	5.7	6.0	6.0	7.4	7.4	7.7	7.7
Clearance for tube removal	mm	3,400	3,400	3,400	3,400	4,500	4,500	4,500	4,500	4,500	4,500	4,500	4,500	

Note:

- 1 usRT = 3,024kcal/h, 1kW = 860kcal/h
2. Standard Tube and Water Side Pressure(Chiller & Cooling Water Circuit)
WCMW003-WCMW005 : 5kg/cm²G(490kPa)
WCMW003-WCMW005 : 8kg/cm²G(785kPa)
3. Currents & Electricity Consumptions are based on 3ø 380V 60Hz
4. Alternate cooling water temperature range available upon request.
5. Power supply wire size is based on the due of metal conduit and 40 °C of ambient temperature.
6. The specifications are subject to change without prior notice.
7. Fouling factor of water side: 0.0001 m² hr C/kcal

WCMW Series

Model name			031		034		038		043		048		054		060		
Cooling capacity	USRT		292	310	320	340	358	380	405	430	452	480	509	540	565	600	
	kW		1,027	1,090	1,125	1,196	1,259	1,336	1,424	1,512	1,589	1,688	1,790	1,899	1,987	2,110	
Chilled water data	Temperature	°C	12-7	13-8	12-7	13-8	12-7	13-8	12-7	13-8	12-7	13-8	12-7	13-8	12-7	13-8	
	Water flow rate	m ³ /h	176.6	187.5	193.7	205.6	216.4	229.8	244.9	260.1	273.4	290.3	307.6	326.6	341.7	362.9	
	Pressure drop	mAq	7.9	8.9	7.7	8.6	7.0	7.8	9.7	10.9	13.0	14.6	7.2	8.2	9.6	10.8	
	Connection size	A(mm)		150	150	150	150	200	200	200	200	200	200	200	200	200	200
		B(inch)		6	6	6	6	8	8	8	8	8	8	8	8	8	8
Cooling Water Data	Temperature	°C	31.0 → 36.5														
	Water flow rate	m ³ /h	386.3	407.2	423.7	446.6	473.5	499.1	535.8	564.8	598.1	630.5	672.9	709.3	747.6	788.1	
	Pressure drop	mAq	7.2	8.0	7.7	8.6	5.8	6.4	7.8	8.7	10.2	11.3	5.9	6.6	7.7	8.5	
	Connection size	A(mm)		250	250	250	250	300	300	300	300	300	300	350	350	350	350
		B(inch)		10	10	10	10	12	12	12	12	12	12	14	14	14	14
Fuel	Temperature	°C	95.0 → 80.0														
	Water Flow rate	ton/h	82.8	86.8	90.8	95.2	101.5	106.4	114.8	120.4	128.2	134.4	144.2	151.2	160.2	168.0	
	Pressure Drop	mAq	4.4	4.8	4.4	4.8	2.0	2.2	2.7	3.0	3.6	4.0	2.5	2.8	3.4	3.7	
	Connection size	A(mm)		125	125	125	125	150	150	150	150	150	150	200	200	200	200
		B(inch)		5	5	5	5	6	6	6	6	6	6	8	8	8	8
	Connection size of Control valve	A(mm)		125	125	125	125	125	125	125	125	150	150	150	150	150	150
		B(inch)		5	5	5	5	5	5	5	5	6	6	6	6	6	6
Electrical data	Source	V	3ø 220/380/440V, 50Hz/60Hz														
	Total current	A	8.9	8.9	8.9	8.9	19.9	19.9	19.9	19.9	21.4	21.4	21.4	21.4	21.4	21.4	
	Wire size	mm ²	4	4	4	4	6	6	6	6	6	6	6	6	6	6	
	Power	kVA	5.8	5.8	5.8	5.8	13.1	13.1	13.1	13.1	14.1	14.1	14.1	14.1	14.1	14.1	
	Absorbent pump no.1	kW(A)	2.2(5.5)	2.2(5.5)	2.2(5.5)	2.2(5.5)	3.0(11.0)	3.0(11.0)	3.0(11.0)	3.0(11.0)	3.0(11.0)	3.0(11.0)	3.0(11.0)	3.0(11.0)	3.0(11.0)	3.0(11.0)	
	Absorbent pump no.2	kW(A)	n/a	n/a	n/a	n/a	2.0(5.2)	2.0(5.2)	2.0(5.2)	2.0(5.2)	2.2(6.7)	2.2(6.7)	2.2(6.7)	2.2(6.7)	2.2(6.7)	2.2(6.7)	
	Refrigerant pump	kW(A)	0.4(1.4)	0.4(1.4)	0.4(1.4)	0.4(1.4)	0.4(1.4)	0.4(1.4)	0.4(1.4)	0.4(1.4)	0.4(1.4)	0.4(1.4)	0.4(1.4)	0.4(1.4)	0.4(1.4)	0.4(1.4)	
	Purge pump	kW(A)	0.4(1.45)	0.4(1.45)	0.4(1.45)	0.4(1.45)	0.4(1.45)	0.4(1.45)	0.4(1.45)	0.4(1.45)	0.4(1.45)	0.4(1.45)	0.4(1.45)	0.4(1.45)	0.4(1.45)	0.4(1.45)	
Dimension	Length	mm	4,789	4,789	4,789	4,789	4,931	4,931	5,473	5,473	5,971	5,971	5,616	5,616	6,114	6,114	
	Width	mm	1,702	1,702	1,702	1,702	2,015	2,015	2,015	2,015	2,015	2,015	2,195	2,195	2,195	2,195	
	Height	mm	2,886	2,886	2,886	2,886	3,260	3,260	3,260	3,260	3,260	3,260	3,680	3,680	3,680	3,680	
Rigging	Operating	ton	13.4	13.4	14	14	19.3	19.3	20.9	20.9	22.0	22.0	27.5	27.5	29.5	29.5	
	Total shipping	ton	11.2	11.2	11.7	11.7	16.2	16.2	17.6	17.6	18.5	18.5	22.7	22.7	24.4	24.4	
	Max Shipping	ton	9.1	9.1	9.5	9.5	13.4	13.4	14.5	14.5	15.1	15.1	18.3	18.3	19.7	19.7	
Clearance for tube removal	mm	4,500	4,500	4,500	4,500	4,600	4,600	5,200	5,200	5,700	5,700	5,200	5,200	5,700	5,700		

Note:

1. 1usRT = 3,024kcal/h, 1kW = 860kcal/h
2. Standard Tube and Water Side Pressure(Chiller & Cooling Water Circuit)
WCMW003-WCMW005 : 5kg/cm²G(490kPa)
WCMW003-WCMW005 : 8kg/cm²G(785kPa)
3. Currents & Electricity Consumptions are based on 3ø 380V 60Hz
4. Alternate cooling water temperature range available upon request.
5. Power supply wire size is based on the due of metal conduit and 40 °C of ambient temperature.
6. The specifications are subject to change without prior notice.
7. Fouling factor of water side: 0.0001 m² hr C/kcal

WCMW Series

Model name		067	074	081	088	095	102							
Cooling capacity	USRT	631	670	697	740	763	810	829	880	895	950	961	1020	
	kW	2,219	2,356	2,451	2,602	2,683	2,848	2,915	3,094	3,147	3,340	3,379	3,587	
Chilled water data	Temperature	°C	12-7	13-8	12-7	13-8	12-7	13-8	12-7	13-8	12-7	13-8	12-7	13-8
	Water flow rate	m ³ /h	381.6	405.2	421.5	447.6	461.4	489.9	501.2	532.2	541.1	574.6	581.0	616.9
	Pressure drop	mAq	12.7	14.3	9.5	10.7	12.1	13.7	15.0	16.9	12.2	13.8	15.2	17.2
	Connection size	A(mm)	200	200	250	250	250	250	250	250	300	300	300	300
		B(inch)	8	8	10	10	10	10	10	10	12	12	12	12
Cooling Water Data	Temperature	°C	31.0 → 36.5											
	Water flow rate	m ³ /h	834.9	880.0	922.1	972.0	1009.0	1064.0	1097.0	1156.0	1184.0	1248.0	1271.0	1340.0
	Pressure drop	mAq	10.0	11.1	6.2	6.9	7.7	8.6	9.5	10.6	8.8	9.8	10.4	11.6
	Connection size	A(mm)	350	350	400	400	400	400	400	400	400	400	400	400
		B(inch)	14	14	16	16	16	16	16	16	16	16	16	16
Fuel	Temperature	°C	95.0 → 80.0											
	Water Flow rate	ton/h	178.9	187.6	197.6	207.2	216.3	226.8	235.0	246.4	253.7	266.0	272.4	285.6
	Pressure Drop	mAq	4.5	4.9	1.3	1.4	1.6	1.8	2.0	2.2	1.7	1.9	2.0	2.2
	Connection size	A(mm)	200	200	200	200	200	200	200	200	200	200	200	200
		B(inch)	8	8	8	8	8	8	8	8	8	8	8	8
	Connection size of Control valve	A(mm)	150	150	200	200	200	200	200	200	200	200	200	200
B(inch)		6	6	8	8	8	8	8	8	8	8	8	8	
Electrical data	Source	V	3ø 220/380/440V, 50Hz/60Hz											
	Total current	A	26.4	26.4	44.2	44.2	44.2	44.2	44.2	44.2	44.2	44.2	44.2	44.2
	Wire size	mm ²	10	10	16	16	16	16	16	16	16	16	16	16
	Power	kVA	17.3	17.3	29.1	29.1	29.1	29.1	29.1	29.1	29.1	29.1	29.1	29.1
	Absorbent pump no.1	kW(A)	4.5(16.0)	4.5(16.0)	4.5(16.0)	4.5(16.0)	4.5(16.0)	4.5(16.0)	4.5(16.0)	4.5(16.0)	4.5(16.0)	4.5(16.0)	4.5(16.0)	4.5(16.0)
	Absorbent pump no.2	kW(A)	2.2(6.7)	2.2(6.7)	5.5(21.0)	5.5(21.0)	5.5(21.0)	5.5(21.0)	5.5(21.0)	5.5(21.0)	5.5(21.0)	5.5(21.0)	5.5(21.0)	5.5(21.0)
	Refrigerant pump	kW(A)	0.4(1.4)	0.4(1.4)	1.5(3.9)	1.5(3.9)	1.5(3.9)	1.5(3.9)	1.5(3.9)	1.5(3.9)	1.5(3.9)	1.5(3.9)	1.5(3.9)	1.5(3.9)
	Purge pump	kW(A)	0.4(1.45)	0.4(1.45)	0.75(2.5)	0.75(2.5)	0.75(2.5)	0.75(2.5)	0.75(2.5)	0.75(2.5)	0.75(2.5)	0.75(2.5)	0.75(2.5)	0.75(2.5)
Dimension	Length	mm	6,639	6,639	6,346	6,346	6,871	6,871	7,371	7,371	7,070	7,070	7,570	7,570
	Width	mm	2,195	2,195	2,680	2,680	2,680	2,680	2,680	2,680	2,910	2,910	2,910	2,910
	Height	mm	3,680	3,680	3,920	3,920	3,920	3,920	3,920	3,920	4,040	4,040	4,040	4,040
Rigging	Operating	ton	31.7	31.7	35.7	35.7	38.2	38.2	40.5	40.5	45	45	47.4	47.4
	Total shipping	ton	26.4	26.4	30.1	30.1	32.3	32.3	34.2	34.2	37.8	37.8	39.8	39.8
	Max Shipping	ton	21.2	21.2	23.8	23.8	25.4	25.4	26.9	26.9	29.6	29.6	31.1	31.1
Clearance for tube removal	mm	6,200	6,200	5,800	5,800	6,300	6,300	6,800	6,800	6,300	6,300	6,800	6,800	

Note:

- 1 usRT = 3,024kcal/h, 1kW = 860kcal/h
2. Standard Tube and Water Side Pressure(Chiller & Cooling Water Circuit)
WCMW003-WCMW005 : 5kg/cm²G(490kPa)
WCMW003-WCMW005 : 8kg/cm²G(785kPa)
3. Currents & Electricity Consumptions are based on 3ø 380V 60Hz
4. Alternate cooling water temperature range available upon request.
5. Power supply wire size is based on the due of metal conduit and 40 °C of ambient temperature.
6. The specifications are subject to change without prior notice.
7. Fouling factor of water side: 0.0001 m² hr C/kcal

Absorption chiller cycle | WC2H

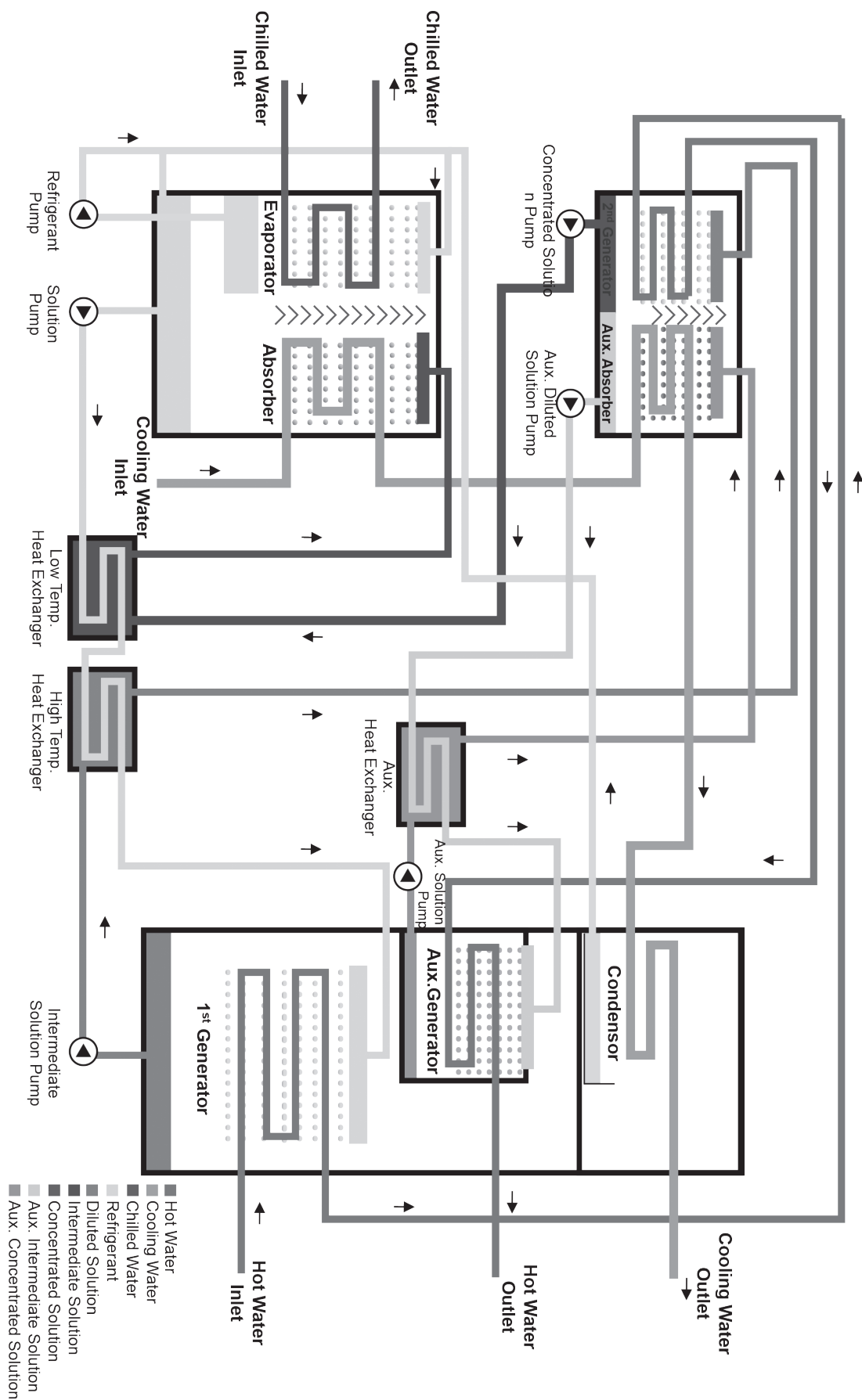

WC2H Series

Model name		008	009	011	014	016	018	021								
Cooling capacity	USRT	73	75	88	90	107	110	132	135	151	155	176	180	205	210	
	kW	258	264	309	316	378	387	464	474	532	545	618	633	721	738	
Chilled water data	Temperature	°C	12-7	13-8	12-7	13-8	12-7	13-8	12-7	13-8	12-7	13-8	12-7	13-8	12-7	13-8
	Water flow rate	m ³ /h	44.3	45.4	53.2	54.4	65.0	66.5	79.8	81.6	91.6	93.7	106.4	108.9	124.1	127.0
	Pressure drop	mAq	6.5	6.8	6.7	7.0	5.5	5.8	5.7	6.0	5.9	6.2	6.2	6.5	8.2	8.6
	Connection size	A(mm)	80	80	80	80	100	100	100	100	125	125	125	125	125	125
		B(inch)	3	3	3	3	4	4	4	4	5	5	5	5	5	5
Cooling Water Data	Temperature	°C	31.0 → 36.5													
	Water flow rate	m ³ /h	95	97	114	116	139	142	171	175	196	200	227	233	265	271
	Pressure drop	mAq	5.7	6.0	6.2	6.5	6.0	6.3	6.6	6.9	5.0	5.2	5.7	6.0	8.1	8.5
	Connection size	A(mm)	125	125	125	125	150	150	150	150	150	150	150	150	200	200
		B(inch)	5	5	5	5	6	6	6	6	6	6	6	6	8	8
Fuel	Temperature	°C	95.0 → 55.0													
	Water Flow rate	ton/h	7.5	7.7	9.0	9.2	11.0	11.2	13.5	13.8	15.5	15.8	18.0	18.4	21.0	21.5
	Pressure Drop	mAq	4.4	4.6	4.7	4.9	4.1	4.3	4.8	5.0	4.8	5.0	5.2	5.5	5.5	5.8
	Pressure Drop(Valve)	mAq	1.0	1.0	1.3	1.4	2.0	2.1	2.9	3.0	2.8	2.9	3.4	3.6	1.9	2.0
	Connection size	A(mm)	65	65	65	65	65	65	65	65	80	80	80	80	80	80
		B(inch)	2 1/2	2 1/2	2 1/2	2 1/2	2 1/2	2 1/2	2 1/2	2 1/2	3	3	3	3	3	3
	Connection size of Control valve	A(mm)	40	40	40	40	40	40	40	40	50	50	50	50	65	65
B(inch)		1 1/2	1 1/2	1 1/2	1 1/2	1 1/2	1 1/2	1 1/2	1 1/2	2	2	2	2	2 1/2	2 1/2	
Electrical data	Source	V	3ø 220/380/440V, 50Hz/60Hz													
	Total current	A	11.8	11.8	11.8	11.8	15.5	15.5	15.5	15.5	15.5	15.5	15.5	15.5	24.0	24.0
	Wire size	mm ²	3.5	3.5	3.5	3.5	3.5	3.5	3.5	3.5	3.5	3.5	3.5	3.5	5.5	5.5
	Power	kVA	7.7	7.7	7.7	7.7	10.2	10.2	10.2	10.2	10.2	10.2	10.2	10.2	15.8	15.8
	Absorbent pump no.1	kW(A)	2.8(6.3)	2.8(6.3)	2.8(6.3)	2.8(6.3)	3.7(9.6)	3.7(9.6)	3.7(9.6)	3.7(9.6)	3.7(9.6)	3.7(9.6)	3.7(9.6)	3.7(9.6)	5.4(17.4)	5.4(17.4)
	Absorbent pump no.2	kW(A)	0.6(2.4)	0.6(2.4)	0.6(2.4)	0.6(2.4)	0.8(2.8)	0.8(2.8)	0.8(2.8)	0.8(2.8)	0.8(2.8)	0.8(2.8)	0.8(2.8)	0.8(2.8)	0.8(3.2)	0.8(3.2)
	Refrigerant pump	kW(A)	0.2(1.1)	0.2(1.1)	0.2(1.1)	0.2(1.1)	0.2(1.1)	0.2(1.1)	0.2(1.1)	0.2(1.1)	0.2(1.1)	0.2(1.1)	0.2(1.1)	0.2(1.1)	0.2(1.1)	0.2(1.1)
	Purge pump	kW(A)	0.4(1.45)													
Dimension	Length	mm	2,630	2,630	2,630	2,630	3,650	3,650	3,650	3,650	3,712	3,712	3,712	3,712	4,732	4,732
	Width	mm	1,750	1,750	1,750	1,750	1,750	1,750	1,750	1,750	1,865	1,865	1,865	1,865	1,865	1,865
	Height	mm	2,400	2,400	2,400	2,400	2,400	2,400	2,690	2,690	2,690	2,690	2,690	2,690	2,690	2,690
Rigging	Operating	ton	5.2	5.2	5.5	5.5	6.9	6.9	7.4	7.4	8.9	8.9	9.5	9.5	11.1	11.1
	Total shipping	ton	4.4	4.4	4.6	4.6	5.9	5.9	6.2	6.2	7.4	7.4	7.8	7.8	9.3	9.3
Clearance for tube removal		mm	2,400	2,400	2,400	2,400	3,400	3,400	3,400	3,400	3,400	3,400	3,400	3,400	4,500	4,500

Note:

- 1usRT = 3,024kcal/h, 1kW = 860kcal/h
2. Standard Tube and Water Side Pressure(Chiller & Cooling Water Circuit): 10kg/cm²G(981kPa)
3. Currents & Electricity Consumptions are based on 3ø 380V 60Hz
4. Alternate cooling water temperature range available upon request.
5. Power supply wire size is based on the due of metal conduit and 40°C of ambient temperature.
6. The specifications are subject to change without prior notice.
7. Fouling factor of water side: 0.0001 m² hr C/kcal

WC2H Series

Model name			024	027	030	034	038	042							
Cooling capacity	USRT		234	240	264	270	293	300	332	340	366	375	410	420	
	kW		824	843	927	949	1,030	1,054	1,167	1,195	1,288	1,318	1,442	1,476	
Chilled water data	Temperature	°C	12-7	13-8	12-7	13-8	12-7	13-8	12-7	13-8	12-7	13-8	12-7	13-8	
	Water flow rate	m ³ /h	141.8	145.2	159.5	163.3	177.3	181.4	200.9	205.6	221.6	226.8	248.2	254.0	
	Pressure drop	mAq	8.4	8.8	8.4	8.8	8.5	8.9	9.0	9.4	9.3	9.7	6.2	6.5	
	Connection size	A(mm)		125	125	150	150	150	150	200	200	200	200	200	200
		B(inch)		5	5	6	6	6	6	8	8	8	8	8	8
Cooling Water Data	Temperature	°C	31.0 → 36.5												
	Water flow rate	m ³ /h	303	310	341	349	379	388	429	440	474	485	530	543	
	Pressure drop	mAq	8.9	9.3	7.8	8.2	8.6	9.0	8.4	8.8	9.2	9.6	7.7	8.1	
	Connection size	A(mm)		200	200	250	250	250	250	250	250	250	250	300	300
		B(inch)		8	8	10	10	10	10	10	10	10	10	10	10
Fuel	Temperature	°C	95.0 → 55.0												
	Water Flow rate	ton/h	24.0	24.5	26.9	27.6	29.9	30.6	33.9	34.7	37.4	38.3	41.9	42.9	
	Pressure Drop	mAq	6.0	6.3	5.5	5.8	5.7	6.0	5.4	5.7	5.7	6.0	5.3	5.6	
	Pressure Drop(Valve)	mAq	2.5	2.6	3.1	3.2	1.5	1.6	1.9	2.0	2.4	2.5	2.9	3.0	
	Connection size	A(mm)		80	80	100	100	100	100	100	100	100	100	100	100
		B(inch)		3	3	4	4	4	4	4	4	4	4	4	4
	Connection size of Control valve	A(mm)		65	65	80	80	80	80	80	80	80	80	80	80
B(inch)			2 1/2	2 1/2	3	3	3	3	3	3	3	3	3	3	
Electrical data	Source	V	3ø 220/380/440V, 50Hz/60Hz												
	Total current	A	24.0	24.0	24.0	24.0	24.0	24.0	27.2	27.2	27.2	27.2	28.2	28.2	
	Wire size	mm ²	5.5	5.5	5.5	5.5	5.5	5.5	8.0	8.0	8.0	8.0	8.0	8.0	
	Power	kVA	15.8	15.8	15.8	15.8	15.8	15.8	17.9	17.9	17.9	17.9	18.5	18.5	
	Absorbent pump no.1	kW(A)	5.4(17.4)	5.4(17.4)	5.4(17.4)	5.4(17.4)	5.4(17.4)	5.4(17.4)	6.4(19.0)	6.4(19.0)	6.4(19.0)	6.4(19.0)	6.7(20.0)	6.7(20.0)	
	Absorbent pump no.2	kW(A)	0.8(3.2)	0.8(3.2)	0.8(3.2)	0.8(3.2)	0.8(3.2)	0.8(3.2)	1.2(4.8)	1.2(4.8)	1.2(4.8)	1.2(4.8)	1.2(4.8)	1.2(4.8)	
	Refrigerant pump	kW(A)	0.4(1.4)	0.4(1.4)	0.4(1.4)	0.4(1.4)	0.4(1.4)	0.4(1.4)	0.4(1.4)	0.4(1.4)	0.4(1.4)	0.4(1.4)	0.4(1.4)	0.4(1.4)	
	Purge pump	kW(A)	0.4(1.45)												
Dimension	Length	mm	4,732	4,732	4,850	4,850	4,850	4,850	4,910	4,910	4,910	4,910	4,995	4,995	
	Width	mm	1,865	1,865	2,180	2,180	2,180	2,180	2,450	2,450	2,450	2,450	2,745	2,745	
	Height	mm	2,690	2,690	2,740	2,740	2,740	2,740	2,920	2,920	2,920	2,920	3,140	3,140	
Rigging	Operating	ton	11.8	11.8	14.9	14.9	16.0	16.0	18.8	18.8	19.8	19.8	26.3	26.3	
	Total shipping	ton	9.8	9.8	12.4	12.4	13.3	13.3	15.7	15.7	16.5	16.5	21.9	21.9	
Clearance for tube removal	mm	4,500	4,500	4,500	4,500	4,500	4,500	4,500	4,500	4,500	4,500	4,500	4,500	4,500	

- Note:
1. 1usRT = 3,024kcal/h, 1kW = 860kcal/h
 2. Standard Tube and Water Side Pressure(Chiller & Cooling Water Circuit): 10kg/cm²G(981kPa)
 3. Currents & Electricity Consumptions are based on 3ø 380V 60Hz
 4. Alternate cooling water temperature range available upon request.
 5. Power supply wire size is based on the due of metal conduit and 40 °C of ambient temperature.
 6. The specifications are subject to change without prior notice.
 7. Fouling factor of water side: 0.0001 m² hr C/kcal

WC2H Series

Model name			047		053		060		068		075		083		
Cooling capacity	USRT		459	470	513	525	586	600	659	675	732	750	806	825	
	kW		1,614	1,652	1,803	1,845	2,060	2,109	2,318	2,372	2,573	2,636	2,833	2,900	
Chilled water data	Temperature	°C	12-7	13-8	12-7	13-8	12-7	13-8	12-7	13-8	12-7	13-8	12-7	13-8	
	Water flow rate	m ³ /h	277.7	284.3	310.2	317.5	354.5	362.9	398.9	408.2	442.7	453.6	487.5	499.0	
	Pressure drop	mAq	8.0	8.4	10.1	10.6	6.7	7.0	8.3	8.7	10.8	11.3	6.5	6.8	
	Connection size	A(mm)		200	200	200	200	250	250	250	250	250	250	300	300
		B(inch)		8	8	8	8	10	10	10	10	10	10	12	12
Cooling Water Data	Temperature	°C	31.0 → 36.5												
	Water flow rate	m ³ /h	594	608	663	679	758	776	853	873	946	970	1,042	1,067	
	Pressure drop	mAq	9.7	10.2	11.4	11.9	7.3	7.6	9.8	10.3	12.9	13.5	7.6	8.0	
	Connection size	A(mm)		300	300	300	300	350	350	350	350	350	350	400	400
		B(inch)		12	12	12	12	14	14	14	14	14	14	16	16
Fuel	Temperature	°C	95.0 → 55.0												
	Water Flow rate	ton/h	46.9	48.0	52.4	53.6	59.9	61.3	67.4	69.0	74.8	76.6	82.3	84.3	
	Pressure Drop	mAq	3.4	3.6	4.6	4.8	3.1	3.2	4.0	4.2	5.1	5.4	4.1	4.3	
	Pressure Drop(Valve)	mAq	1.4	1.5	1.9	2.0	2.4	2.5	3.1	3.2	3.7	3.9	1.7	1.8	
	Connection size	A(mm)		100	100	100	100	125	125	125	125	125	125	125	125
		B(inch)		4	4	4	4	5	5	5	5	5	5	5	5
	Connection size of Control valve	A(mm)		100	100	100	100	100	100	100	100	100	100	125	125
B(inch)			4	4	4	4	4	4	4	4	4	4	5	5	
Electrical data	Source	V	3ø 220/380/440V, 50Hz/60Hz												
	Total current	A	28.2	28.2	40.4	40.4	40.4	40.4	46.9	46.9	46.9	46.9	56.1	56.1	
	Wire size	mm ²	8.0	8.0	14.0	14.0	14.0	14.0	22.0	22.0	22.0	22.0	22.0	22.0	
	Power	kVA	18.5	18.5	26.6	26.6	26.6	26.6	30.8	30.8	30.8	30.8	36.9	36.9	
	Absorbent pump no.1	kW(A)	6.7(20.0)	6.7(20.0)	8.7(27.0)	8.7(27.0)	8.7(27.0)	8.7(27.0)	10.5(33.5)	10.5(33.5)	10.5(33.5)	10.5(33.5)	11.5(37.5)	11.5(37.5)	
	Absorbent pump no.2	kW(A)	1.2(4.8)	1.2(4.8)	3.0(10.0)	3.0(10.0)	3.0(10.0)	3.0(10.0)	3.0(10.0)	3.0(10.0)	3.0(10.0)	3.0(10.0)	4.0(12.0)	4.0(12.0)	
	Refrigerant pump	kW(A)	0.4(1.4)	0.4(1.4)	0.4(1.4)	0.4(1.4)	0.4(1.4)	0.4(1.4)	0.4(1.4)	0.4(1.4)	0.4(1.4)	0.4(1.4)	4.0(12.0)	4.0(12.0)	
	Purge pump	kW(A)	0.4(1.45)												
Dimension	Length	mm	5,540	5,540	6,035	6,035	5,680	5,680	6,180	6,180	6,705	6,705	6,340	6,340	
	Width	mm	2,745	2,745	2,745	2,745	3,480	3,480	3,480	3,480	3,480	3,480	3,800	3,800	
	Height	mm	3,140	3,140	3,140	3,140	3,600	3,600	3,600	3,600	3,600	3,600	3,900	3,900	
Rigging	Operating	ton	28.4	28.4	30.2	30.2	37.5	37.5	39.7	39.7	42.6	42.6	47.5	47.5	
	Total shipping	ton	23.7	23.7	25.2	25.2	31.7	31.7	33.8	33.8	36.6	36.6	39.5	39.5	
Clearance for tube removal	mm	5,200	5,200	5,700	5,700	5,200	5,200	5,700	5,700	6,200	6,200	5,800	5,800		

Note:

1. 1usRT = 3,024kcal/h, 1kW = 860kcal/h
2. Standard Tube and Water Side Pressure(Chiller & Cooling Water Circuit): 10kg/cm²G(981kPa)
3. Currents & Electricity Consumptions are based on 3ø 380V 60Hz
4. Alternate cooling water temperature range available upon request.
5. Power supply wire size is based on the due of metal conduit and 40°C of ambient temperature.
6. The specifications are subject to change without prior notice.
7. Fouling factor of water side: 0.0001 m² hr C/kcal

WC2H Series

Model name			090	098	105	113	120	135							
Cooling capacity	USRT		879	900	952	975	1,026	1,050	1,099	1,125	1,172	1,200	1,319	1,350	
	kW		3,090	3,163	3,344	3,427	3,605	3,690	3,863	3,954	4,120	4,217	4,636	4,745	
Chilled water data	Temperature	°C	12-7	13-8	12-7	13-8	12-7	13-8	12-7	13-8	12-7	13-8	12-7	13-8	
	Water flow rate	m ³ /h	531.8	544.3	575.5	589.7	620.4	635.0	664.8	680.4	709.1	725.8	797.7	816.5	
	Pressure drop	mAq	8.1	8.5	9.9	10.4	6.7	7.0	8.4	8.8	7.9	8.3	10.4	10.9	
	Connection size	A(mm)		300	300	300	300	300	300	300	300	350	350	350	350
		B(inch)		12	12	12	12	12	12	12	12	14	14	14	14
Cooling Water Data	Temperature	°C	31.0 → 36.5												
	Water flow rate	m ³ /h	1,137	1,164	1,230	1,260	1,326	1,357	1,421	1,454	1,516	1,551	1,705	1,745	
	Pressure drop	mAq	9.8	10.3	12.7	13.3	11.7	12.3	13.9	14.6	12.3	12.9	14.7	15.4	
	Connection size	A(mm)		400	400	400	400	400	400	400	400	450	450	450	450
		B(inch)		16	16	16	16	16	16	16	16	18	18	18	18
Fuel	Temperature	°C	95.0 → 55.0												
	Water Flow rate	ton/h	89.8	91.9	97.2	99.6	104.8	107.3	112.3	114.9	119.8	122.6	134.7	137.9	
	Pressure Drop	mAq	5.1	5.3	6.0	6.3	4.4	4.6	5.3	5.6	4.6	4.8	5.7	6.0	
	Pressure Drop(Valve)	mAq	2.1	2.2	2.4	2.5	2.8	2.9	3.2	3.4	1.6	1.7	2.1	2.2	
	Connection size	A(mm)		125	125	125	125	150	150	150	150	150	150	150	150
		B(inch)		5	5	5	5	6	6	6	6	6	6	6	6
	Connection size of Control valve	A(mm)		125	125	125	125	125	125	125	125	150	150	150	150
B(inch)			5	5	5	5	5	5	5	5	6	6	6	6	
Electrical data	Source	V	3ø 220/380/440V, 50Hz/60Hz												
	Total current	A	56.1	56.1	56.1	56.1	75.1	75.1	75.1	75.1	75.1	75.1	75.1	75.1	
	Wire size	mm ²	22.0	22.0	22.0	22.0	38.0	38.0	38.0	38.0	38.0	38.0	38.0	38.0	
	Power	kVA	36.9	36.9	36.9	36.9	49.4	49.4	49.4	49.4	49.4	49.4	49.4	49.4	
	Absorbent pump no.1	kW(A)	11.5(37.5)	11.5(37.5)	11.5(37.5)	11.5(37.5)	17.5(52.5)	17.5(52.5)	17.5(52.5)	17.5(52.5)	17.5(52.5)	17.5(52.5)	17.5(52.5)	17.5(52.5)	
	Absorbent pump no.2	kW(A)	4.0(12.0)	4.0(12.0)	4.0(12.0)	4.0(12.0)	6.0(16.0)	6.0(16.0)	6.0(16.0)	6.0(16.0)	6.0(16.0)	6.0(16.0)	6.0(16.0)	6.0(16.0)	
	Refrigerant pump	kW(A)	1.5(3.9)												
	Purge pump	kW(A)	0.75(2.2)												
Dimension	Length	mm	6,865	6,865	7,365	7,365	6,890	6,890	7,390	7,390	7,490	7,490	8,490	8,490	
	Width	mm	3,800	3,800	3,800	3,800	4,530	4,530	4,530	4,530	4,780	4,780	4,780	4,780	
	Height	mm	3,900	3,900	3,900	3,900	4,150	4,150	4,150	4,150	4,300	4,300	4,300	4,300	
Rigging	Operating	ton	49.4	49.4	52.5	52.5	58.4	58.4	62.6	62.6	64.8	64.8	71.3	71.3	
	Total shipping	ton	41.0	41.0	43.6	43.6	47.8	47.8	51.4	51.4	52.6	52.6	58.2	58.2	
Clearance for tube removal	mm	6,300	6,300	6,800	6,800	6,300	6,300	6,800	6,800	6,400	6,400	7,400	7,400		

Note:

1. 1usRT = 3,024kcal/h, 1kW = 860kcal/h
2. Standard Tube and Water Side Pressure(Chiller & Cooling Water Circuit): 10kg/cm²G(981kPa)
3. Currents & Electricity Consumptions are based on 3ø 380V 60Hz
4. Alternate cooling water temperature range available upon request.
5. Power supply wire size is based on the due of metal conduit and 40°C of ambient temperature.
6. Fouling factor of water side: 0.0001 m² hr C/kcal

WCPX absorption heat pump

Model name		003	007	010	015	020	026	033	040	052	066	
Waste heat source capacity	10 ⁴ kcal/h	13	31	44	67	89	116	147	178	231	293	
	kW	349	814	1,162	1,743	2,324	3,022	3,835	4,649	6,044	7,671	
Hot water Capacity	10 ⁴ kcal/h	30	70	100	150	200	260	330	400	520	660	
	Temperature	°C 55.0 → 59.0										
Hot Water Data	Water flow rate	m ³ /h	8.7	20.3	29.0	43.5	58.0	75.4	95.7	116.0	150.8	191.4
	Pressure drop	mAq	5.8	10.0	7.4	10.1	8.5	12.8	11.0	9.8	10.0	7.5
	Connection size	A(mm)	40	65	65	65	80	100	100	125	125	150
	Temperature	°C 46.0 → 40.0										
Waste heat source system	Water flow rate	m ³ /h	22.5	52.5	74.9	112.4	149.9	194.9	247.3	299.8	389.7	494.6
	Pressure drop	mAq	5.0	4.4	4.4	4.5	4.4	8.6	8.8	8.4	11.3	6.0
	Connection size	A(mm)	65	100	100	100	125	150	150	200	200	250
	Steam Flow rate	kg/h	316	738	1,055	1,582	2,110	2,742	3,481	4,219	5,485	6,962
Steam Data	Steam Inlet Connection	A(mm)	40	50	65	65	80	100	100	125	150	200
	Drain outlet Connection	A(mm)	25	25	25	32	40	50	65	65	80	80
	Steam Control Valve	A(mm)	40	40	40	50	65	65	80	80	100	150
Electrical data	Source	V	3ø 220/380/440V, 50Hz/60Hz									
	Total current	A	7.6	8.9	8.9	9.9	9.9	14.3	14.3	16.0	20.2	20.1
	Wire size	mm ²	3.5	3.5	3.5	3.5	3.5	3.5	3.5	3.5	5.5	5.5
	Power	kVA	5.0	5.9	5.9	6.5	6.5	9.4	9.4	10.5	13.3	13.2
	Absorbent pump no.1	kW(A)	1.2(4.1)	1.5(5.4)	1.5(5.4)	2.4(6.4)	2.4(6.4)	3.4(10.3)	3.4(10.3)	3.7(12.0)	6.6(16.2)	6.6(16.2)
	Refrigerant pump	kW(A)	0.2(1.1)	0.2(1.1)	0.2(1.1)	0.2(1.1)	0.2(1.1)	0.4(1.4)	0.4(1.4)	0.4(1.4)	0.4(1.4)	0.4(1.4)
	Purge pump	kW(A)	0.4(1.6)	0.4(1.6)	0.4(1.6)	0.4(1.6)	0.4(1.6)	0.4(1.6)	0.4(1.6)	0.4(1.6)	0.4(1.6)	0.4(1.6)
Dimension	Length	mm	2,180	2,680	2,680	3,700	3,760	4,780	4,880	4,880	5,630	5,740
	Width	mm	1,400	1,460	1,460	1,460	1,630	1,630	1,680	1,810	2,120	2,300
	Height	mm	2,090	2,210	2,210	2,350	2,600	2,600	2,960	3,270	3,800	4,000
Rigging	Operating	ton	3.0	4.6	4.9	6.5	8.4	10.4	13.1	16.0	23.8	30.6
	Total shipping	ton	2.4	3.6	3.7	4.7	6.1	7.4	9.4	11.5	17.3	22.0
	Max Shipping	ton	2.8	4.2	4.4	5.8	7.5	9.2	11.6	14.1	20.9	26.5

- Note:
- 1kW = 860kcal/h
 - Standard Tube and Water Side Pressure(Waste heat source & Hot Water Circuit): 10kg/cm²G(981kPa)
 - Max. steam pressure : 785kPa = 8kg/cm²G
 - Currents & Electricity Consumptions are based on 3ø 380V 60Hz
 - Power supply wire size is based on the due of metal conduit and 40° C of ambient temperature.
 - The specifications are subject to change without prior notice.
 - Fouling factor of water side: 0.0001 m² hr C/kcal

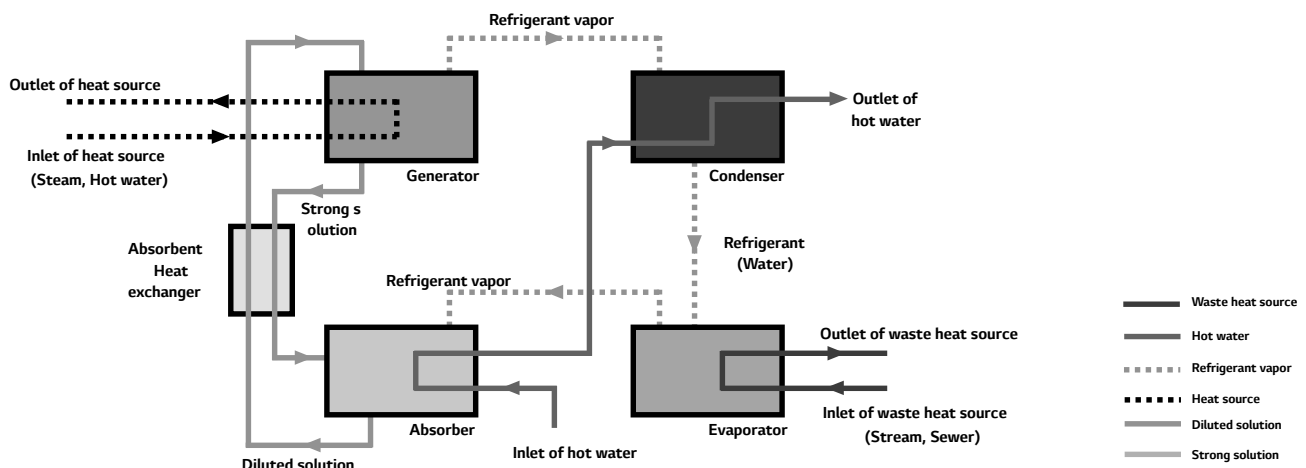

WCPX absorption heat pump

Model name		082	098	115	130	147	163	196	230	260	
Waste heat source capacity	10 ⁴ kcal/h	364	436	511	578	653	724	871	1,022	1,156	
Hot water Capacity	kW	9,530	11,390	13,366	15,109	17,085	18,944	22,780	26,731	30,218	
	10 ⁴ kcal/h	820	980	1,150	1,300	1,470	1,630	1,960	2,300	2,600	
Hot Water Data	Temperature	°C 55.0 → 59.0									
	Water flow rate	m ³ /h	237.8	284.2	333.5	377.0	426.3	472.7	568.4	667.0	754.0
	Pressure drop	mAq	12.4	16.5	19.5	12.6	16.7	21.3	19.8	23.4	15.1
	Connection size	A(mm)	150	200	200	250	250	250	300	350	350
Waste heat source system	Temperature	°C 46.0 → 40.0									
	Water flow rate	m ³ /h	614.5	734.4	861.9	974.3	1101.7	1221.6	1468.9	1723.7	1948.5
	Pressure drop	mAq	10.7	10.3	10.5	2.3	3.1	4.1	12.4	12.6	3.2
	Connection size	A(mm)	250	300	350	400	400	400	400	450	500
Steam Data	Steam Flow rate	kg/h	8,649	10,337	12,130	13,712	15,505	17,193	20,674	24,260	27,424
	Steam Inlet Connection	A(mm)	200	200	250	250	250	250	200 x 2	250 x 2	250 x 2
	Drain outlet Connection	A(mm)	80	100	100	125	125	125	100 x 2	100 x 2	125 x 2
	Steam Control Valve	A(mm)	150	150	200	200	200	200	150 x 2	200 x 2	200 x 2
Electrical data	Source	V	3ø 220/380/440V, 50Hz/60Hz								
	Total current	A	30.0	32.6	32.6	45.6	45.6	45.6	64.1	64.1	91.2
	Wire size	mm ²	8	8	8	14	14	14	30	30	50
	Power	kVA	19.7	21.5	21.5	30	30	30.0	42.2	42.2	60
	Absorbent pump no.1	kW(A)	7.5(25.0)	7.5(25.0)	7.5(25.0)	15(36.0)	15(36.0)	15(36.0)	7.5(25.0) x 2	7.5(25.0) x 2	15(36.0) x 2
	Refrigerant pump	kW(A)	0.4(1.4)	1.5(4.0)	1.5(4.0)	3(5.8)	3(5.8)	3(5.8)	1.5(4.0) x 2	1.5(4.0) x 2	3(5.8) x 2
	Purge pump	kW(A)	0.75(2.5)	0.75(2.5)	0.75(2.5)	0.75(2.5)	0.75(2.5)	0.75(2.5)	0.75(2.5) x 2	0.75(2.5) x 2	0.75(2.5) x 2
Dimension	Length	mm	6,760	6,720	6,860	7,370	8,170	8,970	6,720	6,860	7,370
	Width	mm	2,300	2,780	3,010	3,240	3,240	3,240	5,460	5,920	6,380
	Height	mm	4,000	4,200	4,300	4,400	4,400	4,400	4,300	4,400	4,400
Rigging	Operating	ton	35.1	41.3	48.2	55.8	59.3	62.9	82.6	96.5	112
	Total shipping	ton	25.1	29.4	34.2	40.2	42.0	43.7	29.4	34.2	40.2
	Max Shipping	ton	30.5	36.5	42.7	49.5	52.3	55.0	73.0	85.4	99.0

- Note:
- 1kW = 860kcal/h
 - Standard Tube and Water Side Pressure(Waste heat source & Hot Water Circuit): 10kg/cm²G(981kPa)
 - Max. steam pressure : 785kPa = 8kg/cm²G
 - Currents & Electricity Consumptions are based on 3ø 380V 60Hz
 - Power supply wire size is based on the due of metal conduit and 40 °C of ambient temperature.
 - The specifications are subject to change without prior notice.
 - Fouling factor of water side: 0.0001 m² hr C/kcal

WCPX absorption heat pump (Direct fired)

Model name			003	007	010	015	020	026
Waste heat source capacity		10 ⁴ kcal/h	13	31	44	67	89	116
Hot water Capacity		kW	349	814	1,162	1,743	2,324	3,022
		10 ⁴ kcal/h	30	70	100	150	200	260
Hot Water Data	Temperature	°C	55.0 → 59.0					
	Water flow rate	m ³ /h	8.7	20.3	29.0	43.5	58.0	75.4
	Pressure drop	mAq	5.8	10.0	7.4	10.1	8.5	12.8
	Connection size	A(mm)	40	65	65	65	80	100
Waste heat source system	Temperature	°C	46.0 → 40.0					
	Water flow rate	m ³ /h	22.5	52.5	74.9	112.4	149.9	194.9
	Pressure drop	mAq	5.0	4.4	4.4	4.5	4.4	8.6
	Connection size	A(mm)	65	100	100	100	125	150
Fuel consumption		Nm ³ /h	16.0	37.4	53.4	80.1	106.8	138.9
Electrical data	Source	V	3ø 220/380/440V, 50Hz/60Hz					
	Total current	A	9.8	11.1	13.5	14.8	21.7	26.1
	Wire size	mm ²	3.5	3.5	3.5	3.5	5.5	8.0
	Power	kVA	6.5	7.3	8.9	9.7	14.3	17.2
	Absorbent pump no.1	kW(A)	1.2(4.1)	1.5(5.4)	1.5(5.4)	2.4(6.4)	2.4(6.4)	3.4(10.3)
	Refrigerant pump	kW(A)	0.2(1.1)	0.2(1.1)	0.2(1.1)	0.2(1.1)	0.2(1.1)	0.4(1.4)
	Burner	kW(A)	0.4(1.6)	0.4(1.6)	0.4(1.6)	0.4(1.6)	0.4(1.6)	0.4(1.6)
	Purge pump	kW(A)	0.72(2.2)	0.75(2.2)	1.5(4.6)	2.2(4.9)	5.5(11.8)	5.5(11.8)
Dimension	Length	mm	2,620	3,120	3,120	3,990	4,020	4,820
	Width	mm	2,140	2,190	2,190	2,190	2,540	2,560
	Height	mm	2,030	2,060	2,060	2,120	2,390	2,610
Rigging	Operating	ton	4.5	5.6	6.0	7.9	10.1	12.8
	Total shipping	ton	3.6	4.3	4.4	5.7	7.3	9.3
	Max Shipping	ton	4.3	5.2	5.5	7.2	9.1	11.6

Note:

- 1kW = 860kcal/h
- Standard Tube and Water Side Pressure(Waste heat source & Hot Water Circuit): 10kg/cm²G(981kPa)
- Standard gas pressure : 4,000mmAq
- Standard low calorific power : 9,360 kcal/Nm³
- Currents & Electricity Consumptions are based on 3ø 380V 60Hz
- Power supply wire size is based on the due of metal conduit and 40°C of ambient temperature.
- The specifications are subject to change without prior notice.
- Fouling factor of water side: 0.0001 m² hr C/kcal

WCPX absorption heat pump (Direct fired)





Model name			033	040	052	066	082
Waste heat source capacity		10 ⁴ kcal/h	147	178	231	293	364
Hot water Capacity		kW	3,835	4,649	6,044	7,671	9,530
		10 ⁴ kcal/h	330	400	520	660	820
Hot Water Data	Temperature	°C	55.0 → 59.0				
	Water flow rate	m ³ /h	95.7	116.0	150.8	191.4	237.8
	Pressure drop	mAq	11.0	9.8	10.0	7.5	12.4
	Connection size	A(mm)	100	125	125	150	150
Waste heat source system	Temperature	°C	46.0 → 40.0				
	Water flow rate	m ³ /h	247.3	299.8	389.7	494.6	614.5
	Pressure drop	mAq	8.8	8.4	11.3	6.0	10.7
	Connection size	A(mm)	150	200	200	250	250
Fuel consumption		Nm ³ /h	176.3	213.7	277.8	352.6	438.0
Electrical data	Source	V	3ø 220/380/440V, 50Hz/60Hz				
	Total current	A	30.3	32.0	36.2	42.9	59.3
	Wire size	mm ²	8.0	8.0	14.0	14.0	22.0
	Power	kVA	19.9	21.1	23.8	28.2	39.0
	Absorbent pump no.1	kW(A)	3.4(10.3)	3.7(12.0)	6.6(16.2)	6.6(16.2)	7.5(25.0)
	Refrigerant pump	kW(A)	0.4(1.4)	0.4(1.4)	0.4(1.4)	0.4(1.4)	0.4(1.4)
	Burner	kW(A)	0.4(1.6)	0.4(1.6)	0.4(1.6)	0.4(1.6)	0.75(2.5)
	Purge pump	kW(A)	7.5(16.0)	7.5(16.0)	7.5(16.0)	11.0(22.7)	15.0(29.3)
Dimension	Length	mm	4,940	5,080	6,080	6,710	7,810
	Width	mm	2,830	3,010	3,500	4,020	4,070
	Height	mm	3,030	3,030	3,650	3,650	3,680
Rigging	Operating	ton	16.3	19.9	29.8	39.3	55.9
	Total shipping	ton	11.9	14.5	21.9	28.7	42.8
	Max Shipping	ton	14.8	18.0	26.9	35.3	51.4

Note:

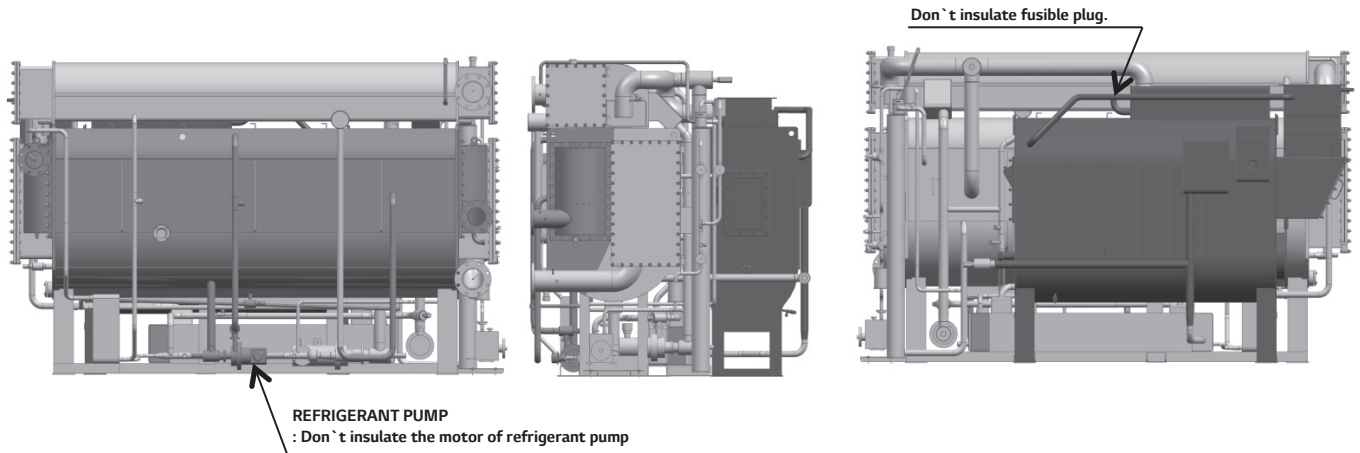
1. 1kW = 860kcal/h
2. Standard Tube and Water Side Pressure(Waste heat source & Hot Water Circuit): 10kg/cm²G(981kPa)
3. Standard gas pressure : 4,000mmAq
4. Standard low calorific power : 9,360 kcal/Nm³
5. Currents & Electricity Consumptions are based on 3ø 380V 60Hz
6. Power supply wire size is based on the due of metal conduit and 40 °C of ambient temperature.
7. The specifications are subject to change without prior notice.
8. Fouling factor of water side: 0.0001 m² hr C/kcal

Direct Fired (WCD Series, H,N,S-TYPE)



-  75mm FOR WARM SURFACE
-  25mm FOR WARM SURFACE
-  19mm FOR COLD SURFACE
-  REMOVAL PART

NOTE.





• Material : Glass Wool, Galvanized Steel Plate, Nitrile-Butadiene Rubber(NBR)

1. Use noncombustible insulation material.
2. Do not insulate motor of refrigerant pump.
3. Insulation area includes piping.
4. The Chiller is coated with an anticorrosive paint at the factory. Finish painting is typically performed in the field after insulating is complete.

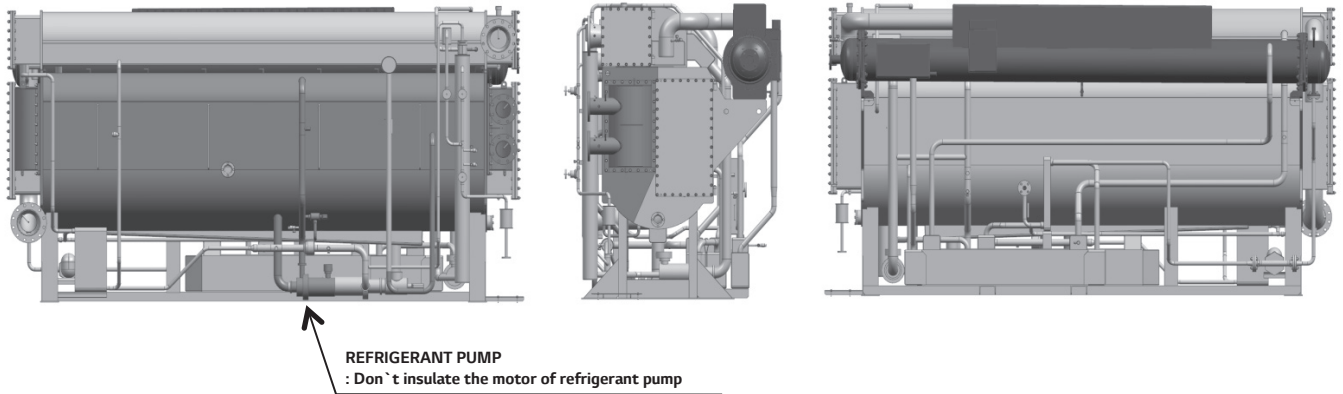
Capacity(RT)	Hot Surface (m ²)		Cold(m ²)
	75mm	25mm	19mm
100	6.3	5.0	4.4
120	6.9	5.3	4.4
150	8.1	6.1	5.9
180	8.7	6.5	5.9
210	10.1	7.1	6.8
240	10.9	7.2	6.8
280	11.9	8.8	8.4
320	12.6	9.0	8.4
360	14.5	9.9	9.9
400	15.3	10.0	9.9
450	17.5	10.5	11.2
500	18.4	10.7	11.2
560	20.0	11.8	13.9
630	21.3	12.6	15
700	22.4	13.3	16.1
800	27.2	14.7	17.3
900	29.0	15.5	19.5
1,000	30.8	16.3	19.9
1,100	36.7	18.4	12.7
1,200	38.7	19.1	13.3
1,300	40.7	19.8	13.8
1,400	45.5	20.7	14.6
1,500	47.0	21.5	15.1

Steam Fired (WCS Series H,S-TYPE)



-  75mm FOR WARM SURFACE
-  25mm FOR WARM SURFACE
-  19mm FOR COLD SURFACE
-  REMOVAL PART

NOTE.

• Material : Glass Wool, Galvanized Steel Plate, Nitrile-Butadiene Rubber(NBR)

1. Use noncombustible insulation material.
2. Do not insulate motor of refrigerant pump.
3. Insulation area includes piping.
4. The Chiller is coated with an anticorrosive paint at the factory. Finish painting is typically performed in the field after insulating is complete.

Capacity(RT)	Hot Surface (m ²)		Cold(m ²)
	75mm	25mm	19mm
100	5.3	3.0	4.4
120	5.3	3.4	4.4
150	7.5	3.7	5.9
180	7.5	4.2	5.9
210	8.4	4.7	6.8
240	8.4	4.8	6.8
280	11.2	5.8	8.4
320	11.2	6.0	8.4
360	12.7	6.5	9.9
400	12.7	6.7	9.9
450	13.4	6.9	11.2
500	13.4	7.2	11.2
560	16.1	8.8	13.9
630	18.1	9.3	15
700	19.9	9.7	16.1
800	21.2	10.7	17.3
900	23.3	11.2	19.5
1,000	25.4	11.7	19.9
1,100	27.2	13.5	12.7
1,200	29.6	13.9	13.3
1,300	31.9	14.3	13.8
1,400	31.3	15.2	14.6
1,500	33.8	15.5	15.1

Keep running a chilled water pump no.1, no.2 and an air conditioner continuously in order to protect freezing trouble during the dilution operation. (about 15min.)

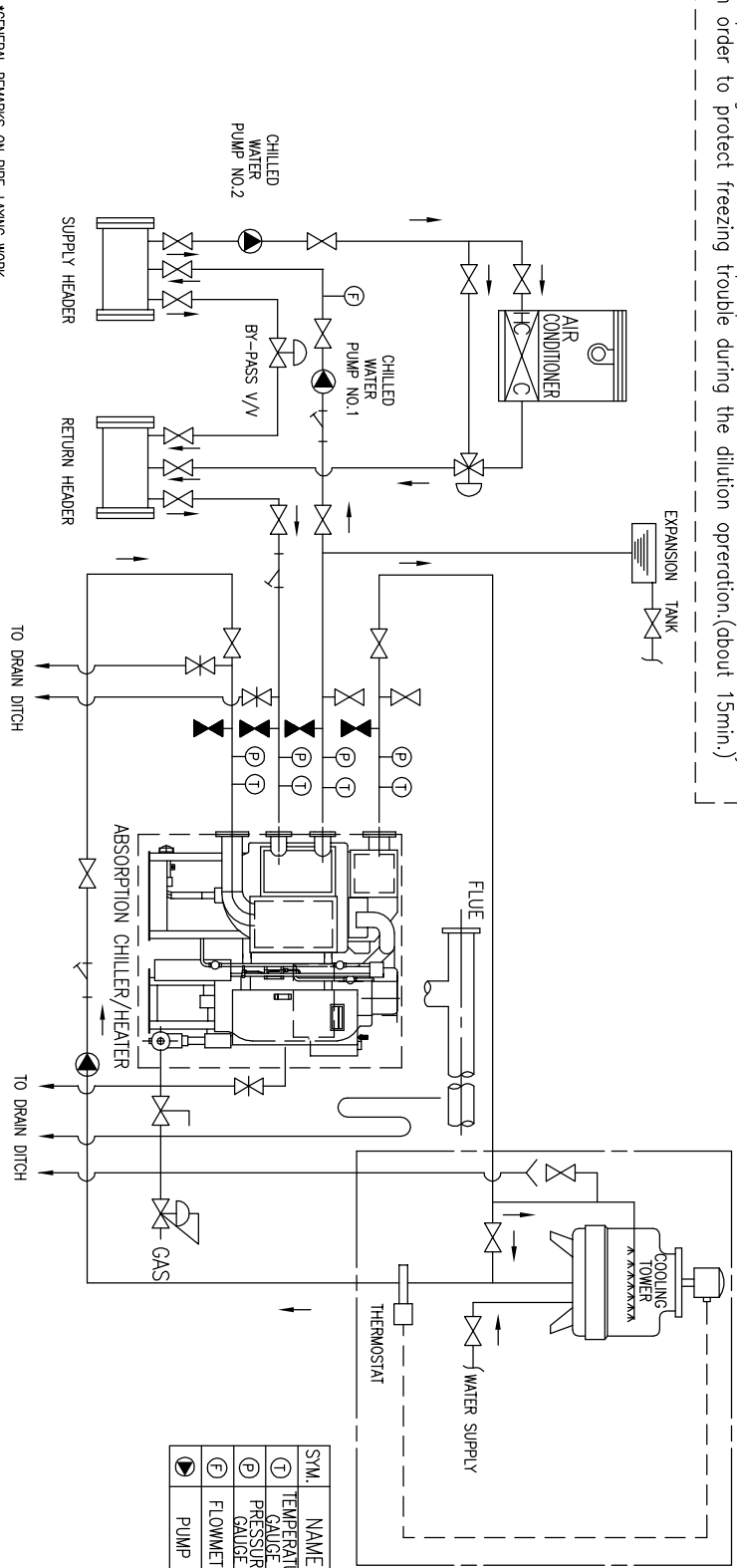

SYM.	NAME	SYM.	NAME
Ⓣ	TEMPERATURE GAUGE	Ⓢ	STRAINER
Ⓟ	PRESSURE GAUGE	Ⓢ	DRAIN V/V
ⓕ	FLOWMETER	Ⓢ	CHEMICAL V/V
Ⓜ	PUMP	Ⓢ	VALVE

***GENERAL REMARKS ON PIPE-LAYING WORK**

1. LGE supply boundary line. ([-----])
2. See [OUTLINE] drawing for dimension, size of connections.
3. [H-N-TYPE : 10kg/cm² G, S-TYPE : 8kg/cm²] is the maximum operation pressure of Chilled/Cooling water pipe line.
4. See [CONTROL OF COOLING WATER TEMPERATURE] drawing for information of controller. ([-----])
5. Provide separate Chilled/Cooling water pumps for each absorption machine.
Flow rate of Chilled/Cooling water should meet the specification individually the specifications.
6. Place a bleeder at the Cooling water line for control of Cooling water quality.
7. Install a more or less 10-meshed strainer.
8. Flue and stack connection.
 - 1) Flue and stack should be heat insulated with a condensate drain equipped.
 - 2) Do not connect the flue to incinerator stack.
 - 3) One individual stack for each chiller is recommendable. Common stack can be used if it is due to space limitation. However, each unit should be installed with a damper to prevent exhaust flowing backward when unit not in operation. Also, operator should always check if damper is opened before starting.
 - 4) Draft regulator can be used, if static pressure inside the stack is unstable.
9. Chilled/Cooling water pipe maintenance.
 - 1) To ease maintenance, a stop valve should be placed around the Inlet/Outlet of Chilled/Cooling water supplying pipe line.
 - 2) Place both temperature sensor and pressure gauge around the Inlet/Outlet of Chilled/Cooling water supplying pipe line.
 - 3) Vent valve must be located higher than water levels of the Chilled/Cooling water headers.
 - 4) A drain valve should be placed at lower part of between unit and stop valve of Chilled/Cooling water supplying pipe line.
 - 5) For chemical cleaning purposes, a valve should be placed at between unit and Inlet/Outlet stop valve.
10. For safety reasons, place both manual and automatic stop valve at supplying pipe line.
 - 1) When supplying gas for the first time, check if gas is supplied to unite properly.
 - 2) Exhaust possible termoin N₂/CO₂ gas that could cause unstable combustion and failure ignition.
 - 3) when chiller is not in operation for a long period, check 1)2) in before operation.

Piping diagram

Steam absorption chiller (H,S Type)

Keep running a chilled water pump no.1,no.2 and an air conditioner continuously in order to protect freezing trouble during the dilution operation.(about 15min.)

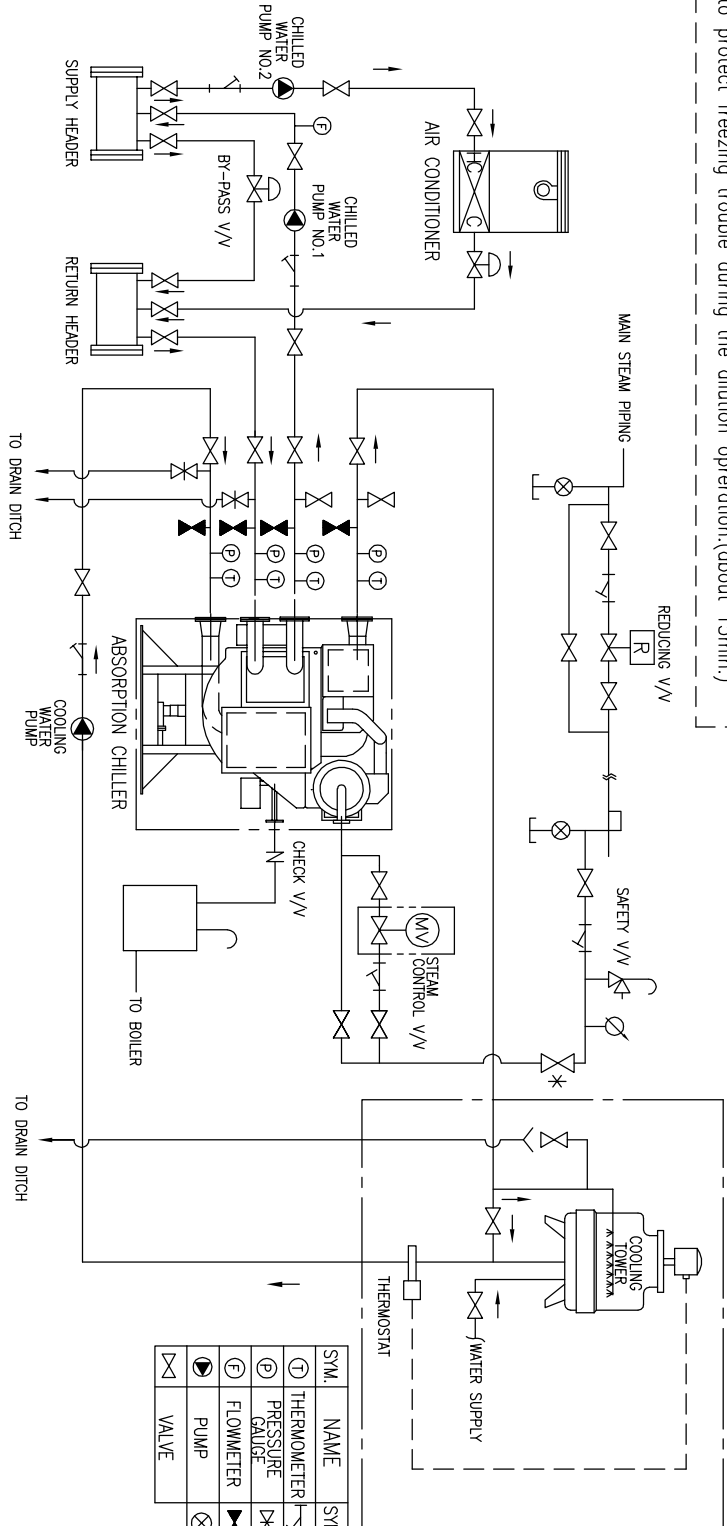

GENERAL REMARKS ON PIPE-LAYING WORK

- The range of equipment to be supplied by LGE is enclosed by the two-dot chain line. ()
- For pipe diameter, pipe connections, etc., refer to the mechanical layout diagram. [OUTLINE]
- The maximum operating pressure in the chilled and cooling water is H-Type: 10Kg/cm²G, S-Type: 8Kg/cm²G.
- Concerning temperature control of cooling water, refer to another diagram. [CONTROL OF COOLING WATER TEMPERATURE] ()
- Provide separate chilled and cooling water pumps for each absorption machine. Flow rate of chilled and cooling water should confirm to the specifications.
- Provide a bleeder in the cooling water line for control of cooling water quality.
- Install a strainer having a mesh of 10 or so.
- Install a steam stop v/v(*) to shut off a steam line to a chiller when the chiller is not operate.
- Provide the inlet and outlet piping for chilled and cooling water with the stop valve so that the piping can be cleaned easily.
 - Install thermometers and pressure gauges at locations convenient for servicing in the inlet and outlet water lines.
 - Install air vent valves for water lines at a position above the absorption machine.
 - Install drain valves for water lines at a position bottom the absorption machine, and then extend them up to the ditch.
 - For chemical cleaning, install the stop valves for cleaning between the unit and each stop valve at the inlet or outlet.

Keep running a chilled water pump no.1,no.2 and an air conditioner continuously in order to protect freezing trouble during the dilution operation.(about 15min.)

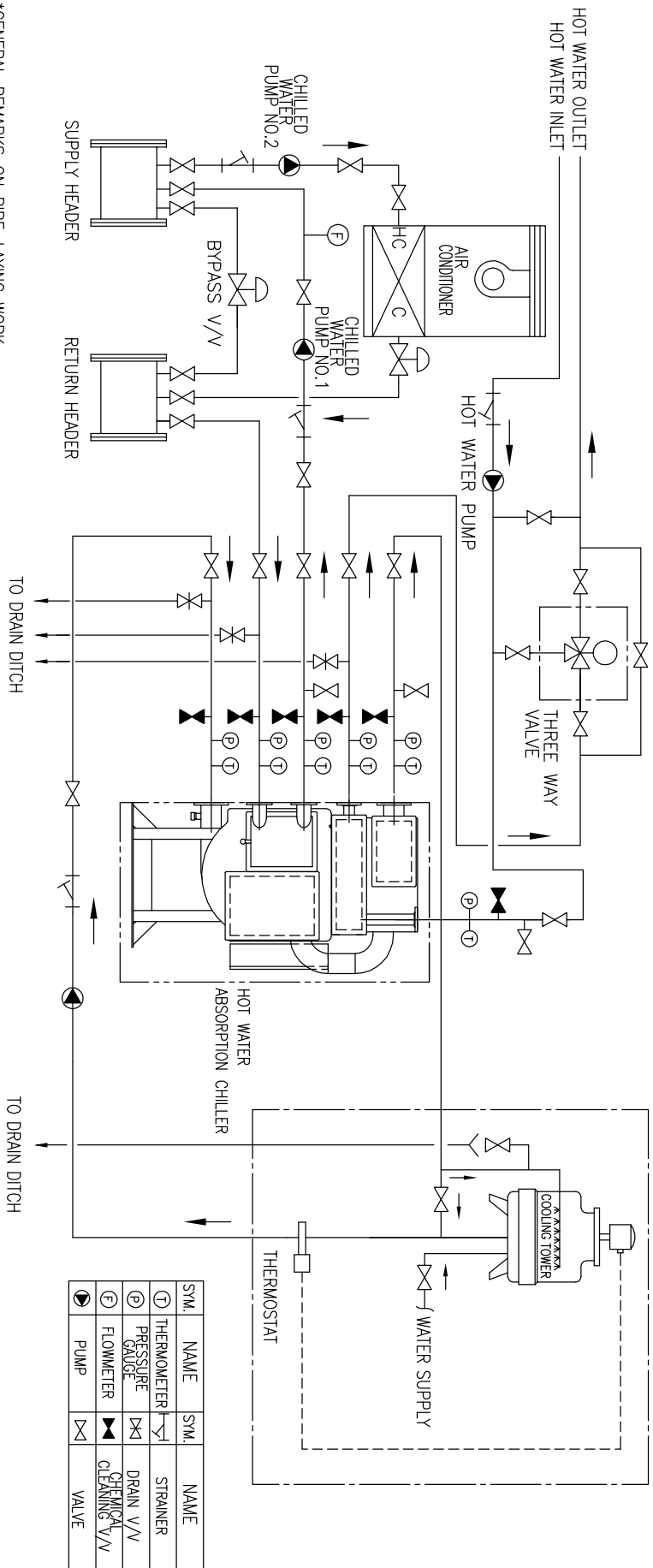

***GENERAL REMARKS ON PIPE-LAYING WORK**

1. The range of equipment to be supplied by LGE is enclosed by the two-dot chain line.()
2. For pipe diameter, pipe connections, etc., refer to the mechanical layout diagram.
3. The maximum operating pressure in the chilled, cooling and hot water is 8Kg/cm²G. (For WCMW003~W005 5Kg/cm²G is standard.)
4. Concerning temperature control of cooling water, refer to another diagram.
5. [CONTROL OF COOLING WATER TEMPERATURE]()
6. Provide separate chilled, cooling and hot water pumps for each absorption machine.
7. Flow rate of chilled, cooling and hot water should confirm to the specifications.
8. Provide a bleeder in the cooling water line for control of cooling water quality.
9. Install a strainer having a mesh of 10 or so.
10. Provide the inlet and outlet piping for chilled, cooling and hot water with the stop valve so that the piping can be cleaned easily.
 - 1) Install thermometers and pressure gauges at locations convenient for servicing in the inlet and outlet water lines.
 - 2) Install air vent valves for water lines at a position above the absorption machine.
 - 3) Install drain valves for water lines at a position above the bottom of the absorption machine, and then extend them up to the ditch.
 - 4) For chemical cleaning, install the stop valves for cleaning between the unit and each stop valve at the inlet or outlet.

Control diagram of cooling water inlet temperature

Direct/Steam/Hot water fired absorption chiller

Ensure that the cooling water temperature does not fall more than 10°C below the design temperature. For example, if the cooling water inlet temperature is 32°C, ensure that the

cooling water temperature does not fall below 22°C. During starting, however, a lower temperature is permissible until the machine reaches the rated capacity.

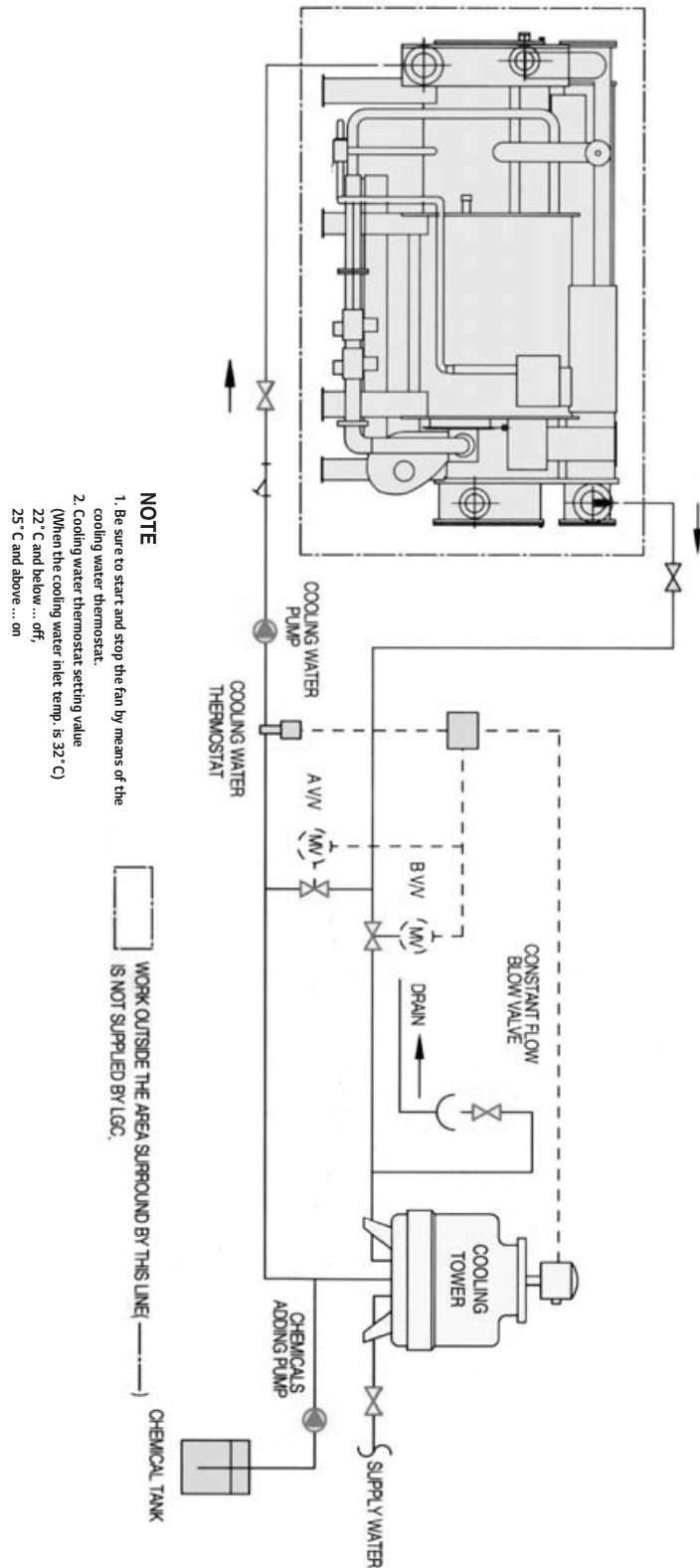

Standard of water quality

The cooling water of an open-type recycling cooling tower lowers temperature of the cooling water using vaporized latent-heat and is reused. In this case, the water is evaporated and dissolved salts, Hardness materials, sulfate ion, etc. in the water will increase. Namely, condensation phenomena of such materials occurs in the water, and water quality will gradually

be degraded. As the water and air always come in contact with each other in the cooling tower, sulfurous acidgas, dust, sand, etc. in the atmosphere will mix into the water, further degrading the water quality. in the cooling water system, problems with water are caused by these factors.

Typical problems are corrosion, scales and slimes.

Model	Cooling Water		Chilled Water		Tendency	
	One-pass or Circulating	Make-up water	Circulating water	Make-up	Corrosion	Scale
pH(25°C)	6.5~8.0	6.5~8.0	6.5~8.0	6.5~8.0	0	0
Electrical conductivity (25°C μs/cm)	Max.800	Max.200	Max.500	Max.200	0	0
Alkalinity (ppm)	Max.100	Max.50	Max.100	Max.50		0
Total hardness (ppm)	Max.200	Max.50	Max.100	Max.50	0	
Chlorine ion (ppm)	Max.200	Max.50	Max.100	Max.50	0	
Sulfuric acid ion (ppm)	Max.200	Max.50	Max.100	Max.50	0	
Total ion (ppm)	Max.1.0	Max.0.3	Max.1.0	Max.0.3	0	
Sulfur ion (ppm)	No trace	No trace	No trace	No trace	0	
Ammonium ion (ppm)	Max.1.0	Max.1.0	Max.0.5	Max.0.2	0	
Silica (ppm)	Max.50	Max.30	Max.50	Max.30		0
Free carbonic acid (ppm)	*****	*****	Max.1.0	Max.1.0	0	

Combustion Sequence Diagram

■ GAS

GAS PRESSURE : 200mmAq

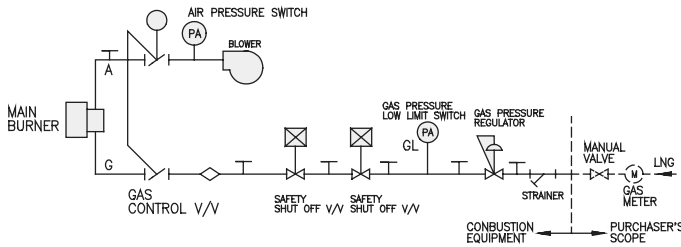

GAS PRESSURE : 900~4,000mmAq

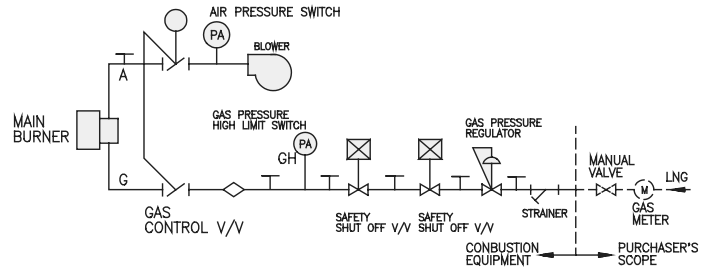

■ OIL

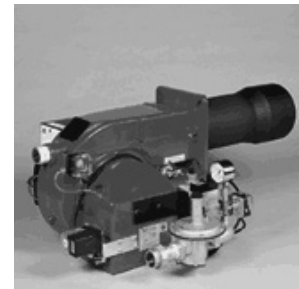
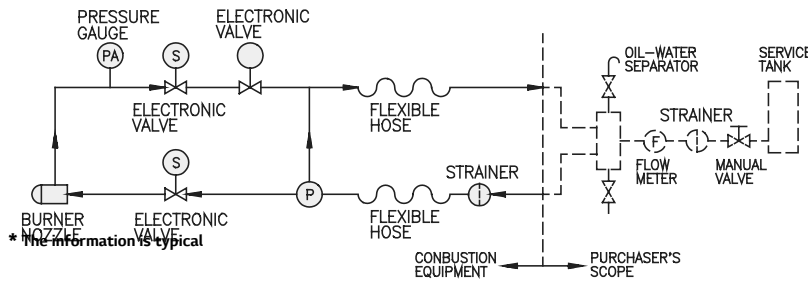

Flue and Stack Connection

1. Local regulations regarding exhaust of direct-fired burners must be adhered to. These instructions shown are typical and are not meant to supersede local codes in any way.
2. The steel stack should be lined on the interior surface to protect the stack from corrosion due to moisture in the exhaust gas.
3. The flue and stack must be heat insulated and provided with a condensate drain.
4. Do not connect the flue to an incinerator stack.
5. Place the top of the stack within a sufficient distance from the cooling towers to prevent contamination.
6. Provide a barometric draft regulator or damper if fluctuations or downdraft in static pressure are expected inside the flue. Some means of controlling the flue draft may be necessary to insure that proper combustion efficiency is maintained at all times.
7. If a common stack is to be used, exhaust must be prevented from floeing into the unit(s) that are not in operation.
8. The draft pressure at the flue flange should be designed for a maximum negative pressure of -5mmH₂O.

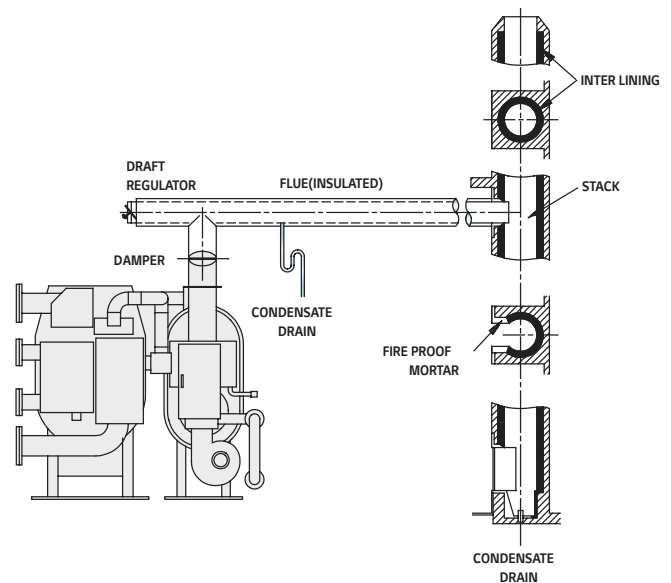

Multi-Sectional shipment

WCDH Series

Model	Entrance dimension of total unit				Entrance dimension of 3-sectional shipment											
					Upper shell				Lower Shell				High temperature generator			
	Length	Width	Height	Weight	Length	Width	Height	Weight	Length	Width	Height	Weight	Length	Width	Height	Weight
	mm	mm	mm	ton	mm	mm	mm	ton	mm	mm	mm	ton	mm	mm	mm	ton
WCDH010S	3,095	2,035	2,110	3.8	2,965	1,180	530	0.7	2,965	1,520	2,010	1.9	1,590	760	1,930	1.2
WCDH012S	3,095	2,035	2,110	4.0	2,965	1,180	530	0.8	2,965	1,520	2,010	2.1	1,590	760	1,930	1.2
WCDH015S	3,945	2,035	2,110	4.6	3,945	1,180	530	1.0	3,945	1,520	2,010	2.4	1,800	760	1,930	1.2
WCDH018S	3,945	2,165	2,110	5.0	3,945	1,180	530	1.0	3,945	1,520	2,010	2.6	1,950	880	1,930	1.4
WCDH021S	3,995	2,220	2,455	5.8	3,995	1,250	600	1.2	3,995	1,520	2,155	3.0	2,100	880	1,930	1.6
WCDH024S	3,995	2,240	2,455	6.1	3,995	1,250	600	1.2	3,995	1,520	2,155	3.1	2,270	900	2,110	1.7
WCDH028S	5,015	2,295	2,455	7.4	5,015	1,250	600	1.5	5,015	1,520	2,155	3.8	2,450	900	2,110	1.9
WCDH032S	5,015	2,295	2,455	7.8	5,015	1,250	600	1.6	5,015	1,520	2,155	4.0	2,750	910	2,130	2.0
WCDH036S	5,090	2,500	2,630	8.7	5,090	1,385	670	1.8	5,090	1,730	2,550	4.6	3,250	910	2,130	2.2
WCDH040S	5,090	2,585	2,630	9.4	5,090	1,385	670	2.0	5,090	1,730	2,550	5.0	3,000	1,000	2,370	2.4
WCDH045S	5,100	2,835	2,965	11.0	5,100	1,520	710	2.3	5,100	1,910	2,625	5.9	3,000	1,040	2,380	2.8
WCDH050S	5,100	2,925	2,965	12.4	5,100	1,520	710	2.4	5,100	1,910	2,625	6.1	3,190	1,130	2,600	3.4
WCDH056S	5,510	3,095	3,335	15.0	5,200	1,600	870	2.9	5,200	2,140	2,980	7.3	3,350	1,130	2,600	4.0
WCDH063S	5,720	3,220	3,335	17.5	5,720	1,600	870	3.3	5,720	2,140	2,980	8.6	3,230	1,370	3,080	4.5
WCDH070S	6,210	3,220	3,335	19.5	6,210	1,600	870	3.7	6,210	2,140	2,980	9.5	3,500	1,350	3,080	5.0
WCDH080S	5,810	3,870	3,590	21.0	5,835	1,770	1,090	4.0	5,835	2,570	2,840	10.3	3,650	1,400	3,600	6.0
WCDH090S	6,400	4,120	3,640	22.5	6,330	1,770	1,090	4.3	6,330	2,570	2,840	11.0	3,700	1,500	3,600	7.0
WCDH100S	6,900	4,120	3,640	24.0	6,790	1,770	1,090	4.6	6,790	2,570	2,840	11.8	3,900	1,500	3,600	8.0
WCDH110S	6,400	4,470	3,840	26.0	6,260	2,200	1,140	5.0	6,260	2,890	3,000	12.7	4,320	1,620	3,600	9.0
WCDH120S	6,900	4,470	3,840	28.0	6,780	2,200	1,140	5.3	6,780	2,890	3,000	13.7	4,620	1,620	3,600	10.0
WCDH130S	7,400	4,470	3,840	30.0	7,280	2,200	1,140	5.7	7,280	2,890	3,000	14.7	4,920	1,620	3,600	11.0
WCDH140S	7,050	4,870	3,940	32.0	6,840	2,300	1,170	6.1	6,840	3,500	3,000	15.7	4,940	1,870	3,800	12.0
WCDH150S	7,550	4,870	3,940	34.0	7,340	2,300	1,170	6.5	7,340	3,500	3,000	16.6	5,140	1,870	3,800	13.0

Multi-Sectional shipment

WCSH Series

Model	Entrance dimension of total unit				Entrance dimension of 3-sectional shipment											
					Upper shell				Lower Shell				High temperature generator			
	Length	Width	Height	Weight	Length	Width	Height	Weight	Length	Width	Height	Weight	Length	Width	Height	Weight
	mm	mm	mm	ton	mm	mm	mm	ton	mm	mm	mm	ton	mm	mm	mm	ton
WCSH010	2,930	1,880	2,105	3.5	2,930	1,520	2,105	0.7	2,930	1,700	1,970	1.9	2,600	500	700	0.9
WCSH012	2,930	1,880	2,105	3.9	2,930	1,520	2,105	0.8	2,930	1,700	1,970	2.1	2,600	500	700	1.0
WCSH015	3,920	1,880	2,110	4.6	3,920	1,520	2,105	1.0	3,920	1,700	1,970	2.4	3,620	500	700	1.2
WCSH018	3,920	1,880	2,150	4.9	3,920	1,520	2,105	1.0	3,920	1,700	1,970	2.6	3,620	500	700	1.3
WCSH021	3,920	2,070	2,455	5.7	3,920	1,513	2,455	1.2	3,920	1,900	2,300	3.0	3,650	530	790	1.5
WCSH024	3,920	2,070	2,455	5.9	3,920	1,513	2,455	1.2	3,920	1,900	2,300	3.1	3,650	530	790	1.6
WCSH028	4,940	2,140	2,455	7.1	4,940	1,513	2,455	1.5	4,940	1,900	2,300	3.8	4,680	530	790	1.9
WCSH032	4,940	2,140	2,455	7.6	4,940	1,513	2,455	1.6	4,940	1,900	2,300	4.0	4,680	530	790	2.0
WCSH036	5,000	2,270	2,630	8.6	5,000	1,730	2,630	1.8	5,000	2,000	2,510	4.6	4,730	630	850	2.3
WCSH040	5,000	2,270	2,630	9.6	5,000	1,730	2,630	2.0	5,000	2,000	2,510	5.1	4,730	630	850	2.6
WCSH045	5,015	2,455	2,990	11.3	5,015	1,910	2,965	2.1	5,015	2,100	2,590	5.4	4,860	720	920	3.8
WCSH050	5,015	2,455	2,990	12.5	5,015	1,910	2,965	2.4	5,015	2,100	2,590	6.1	4,860	720	920	4.1
WCSH056	5,230	2,690	3,340	14.8	5,230	2,140	3,335	2.9	5,230	2,290	2,940	7.3	4,900	770	1,070	4.6
WCSH063	5,720	2,690	3,340	17.6	5,720	2,140	3,335	3.3	5,720	2,290	2,940	8.6	5,450	770	1,070	5.7
WCSH070	6,210	2,690	3,340	19.9	6,210	2,140	3,335	3.7	6,210	2,290	2,940	9.5	5,940	770	1,070	6.7
WCSH080	5,835	3,160	3,590	21.3	5,835	2,570	3,590	4.0	5,835	3,090	2,810	10.3	5,600	1,000	1,230	7.1
WCSH090	6,330	3,160	3,590	22.7	6,330	2,570	3,590	4.3	6,330	3,090	2,810	11.0	6,000	1,000	1,230	7.4
WCSH100	6,790	3,160	3,590	24.1	6,790	2,570	3,590	4.6	6,790	3,090	2,810	11.8	6,530	1,000	1,230	7.8
WCSH110	6,260	3,250	3,860	26.0	6,260	3,370	3,820	5.0	6,260	2,870	2,850	12.7	6,000	930	1,230	8.3
WCSH120	6,780	3,250	3,860	27.8	6,780	3,370	3,820	5.3	6,780	2,870	2,850	13.7	6,990	930	1,230	8.8
WCSH130	7,280	3,250	3,860	29.7	7,280	3,370	3,820	5.7	7,280	2,870	2,850	14.7	6,000	930	1,230	9.3
WCSH140	6,840	3,590	3,880	31.5	6,840	3,500	3,880	6.1	6,840	3,000	2,950	15.7	6,540	950	1,310	9.8
WCSH150	7,340	3,590	3,880	33.4	7,340	3,500	3,880	6.5	7,340	3,000	2,950	16.6	7,040	950	1,310	10.3

WCDH

1. All external water piping are to be provided with welded ANSI 150PSIG RF flanges by the customer.
2. Installation and service clearance as follows :
 Logitudinal distance - 1,000mm
 Top - 200mm
 Control panel side - 1,200mm
3. Please refer to the LG Electronics drawings for the piping direction

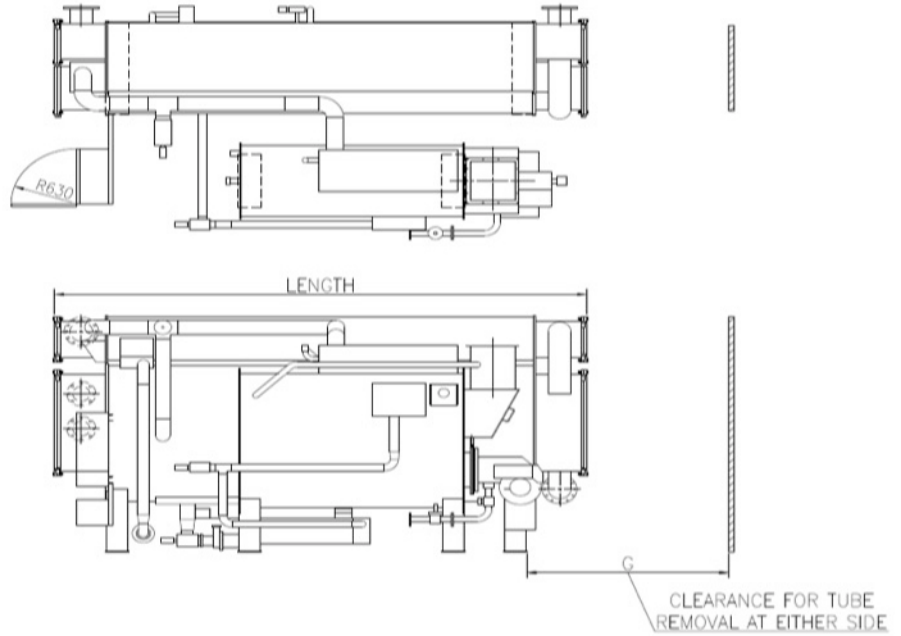

Model	Dimension(mm)			Nozzle connection (B)				Clearance (mm)
	Length	Width	Height	A	B	C	D	G
WCDH010S	2,895	1,965	2,070	5	4	4	5	2,400
WCDH012S	2,895	1,965	2,070	5	4	4	5	2,400
WCDH015S	3,745	1,965	2,070	5	4	4	5	3,400
WCDH018S	3,745	2,095	2,070	5	4	4	5	3,400
WCDH021S	3,795	2,150	2,415	6	5	5	6	3,400
WCDH024S	3,795	2,170	2,415	6	5	5	6	3,400
WCDH028S	4,815	2,225	2,415	8	6	6	8	4,500
WCDH032S	4,815	2,225	2,415	8	6	6	8	4,500
WCDH036S	4,890	2,430	2,590	8	6	6	8	4,500
WCDH040S	4,890	2,515	2,590	8	6	6	8	4,500
WCDH045S	4,900	2,765	2,925	10	8	8	10	4,500
WCDH050S	4,900	2,855	2,925	10	8	8	10	4,500
WCDH056S	5,310	3,025	3,295	12	8	8	12	4,500
WCDH063S	5,520	3,150	3,295	12	8	8	12	5,200
WCDH070S	6,010	3,150	3,295	12	8	8	12	5,700

WCDH

1. All external water piping are to be provided with welded ANSI 150PSIG RF flanges by the customer.
2. Installation and service clearance as follows :
 Logitudinal distance - 1,000mm
 Top - 200mm
 Control panel side - 1,200mm
3. Please refer to the LG Electronics drawings for the piping direction

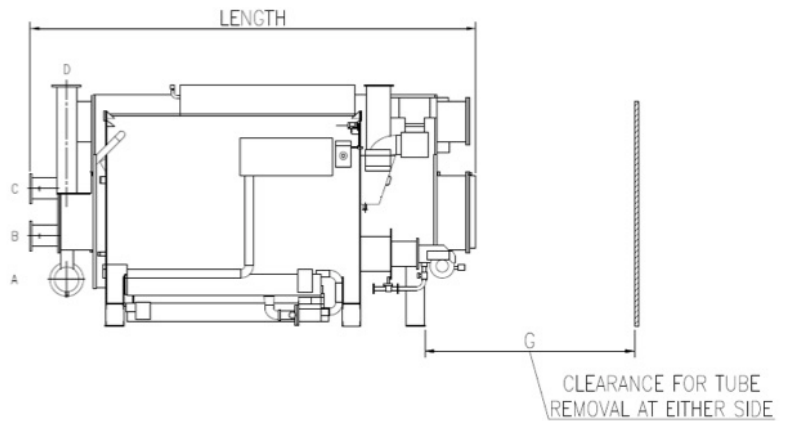
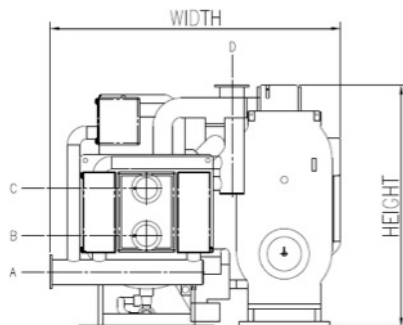
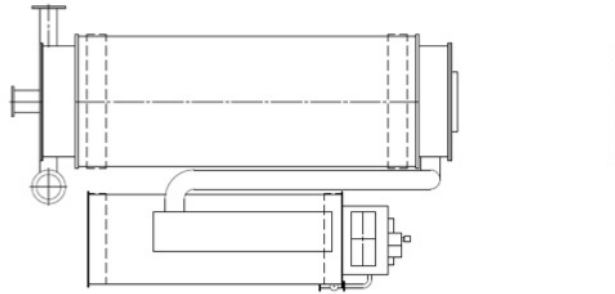

Model	Dimension(mm)			Nozzle connection (B)				Clearance (mm)
	Length	Width	Height	A	B	C	D	G
WCDH080S	5,635	3,800	3,550	14	10	10	14	5,200
WCDH090S	6,130	3,920	3,600	14	10	10	14	5,700
WCDH100S	6,590	3,920	3,600	14	10	10	14	6,200
WCDH110S	6,060	4,200	3,780	16	12	12	16	5,700
WCDH120S	6,580	4,300	3,780	16	12	12	16	6,200
WCDH130S	7,080	4,300	3,780	16	12	12	16	6,700
WCDH140S	6,640	4,700	3,840	16	14	14	16	6,200
WCDH150S	7,140	4,850	3,840	16	14	14	16	6,700

WCDH

1. The foundation and the floor must be sufficiently strong to support the unit weight.
2. Provide a floor drain near chiller foundation.
3. Only if foundation anchoring is required, anchor bolts, nuts and washers, shall be supplied together with chiller. Anchor bolts must be fixed on the foundation prior to chiller installation.
4. Unit must be leveled before startup.
(Horizontal level must be below than 2mm/1,000mm)

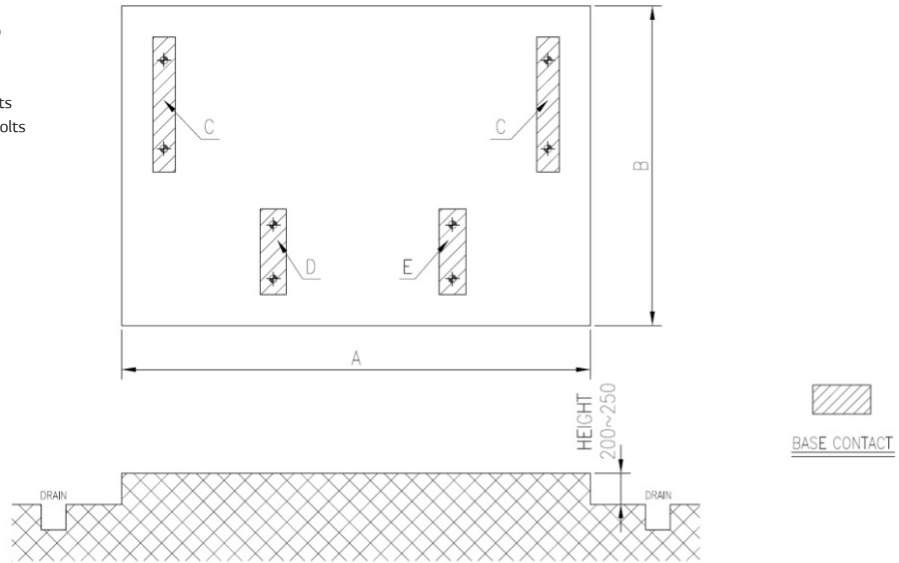

Model	Dimension(mm)		Nozzle connection (B)			
	A	B	C	D	E	Total
WCDH010S	2,500	2,000	1.7	0.7	0.9	5.0
WCDH012S	2,500	2,000	1.8	0.7	0.9	5.2
WCDH015S	3,500	2,000	2.3	0.7	0.9	6.2
WCDH018S	3,500	2,100	2.5	0.9	1.1	7.0
WCDH021S	3,500	2,150	3.0	1.0	1.2	8.2
WCDH024S	3,500	2,150	3.1	1.1	1.3	8.6
WCDH028S	4,500	2,250	4.0	1.2	1.4	10.6
WCDH032S	4,500	2,250	4.1	1.3	1.5	11.0
WCDH036S	4,500	2,500	4.7	1.4	1.6	12.4
WCDH040S	4,500	2,550	5.0	1.4	1.7	13.1
WCDH045S	4,500	2,900	5.9	1.7	2.0	15.5
WCDH050S	4,500	2,900	6.4	2.1	2.4	17.3
WCDH056S	4,500	3,100	8.0	2.4	2.8	21.2
WCDH063S	5,050	3,300	9.3	2.7	3.1	24.4
WCDH070S	5,550	3,300	10.4	3.0	3.4	27.2
WCDH080S	5,050	3,750	11.6	4.0	4.4	31.6
WCDH090S	5,550	4,000	12.0	4.7	5.2	33.9
WCDH100S	6,100	4,000	12.7	5.6	6.1	37.1
WCDH110S	5,150	4,150	13.5	6.4	7.0	40.4
WCDH120S	5,700	4,150	14.4	7.4	7.9	44.1
WCDH130S	6,200	4,150	15.5	8.3	8.8	48.1
WCDH140S	5,700	4,600	16.6	9.2	9.7	52.1
WCDH150S	6,200	4,600	17.5	10.1	10.8	55.9

WCDN

- All external water piping are to be provided with welded ANSI 150PSIG RF flanges by the customer.
- Installation and service clearance as follows :
 Logitudinal distance - 1,000mm
 Top - 200mm
 Control panel side - 1,200mm
- Please refer to the LG Electronics drawings for the piping direction

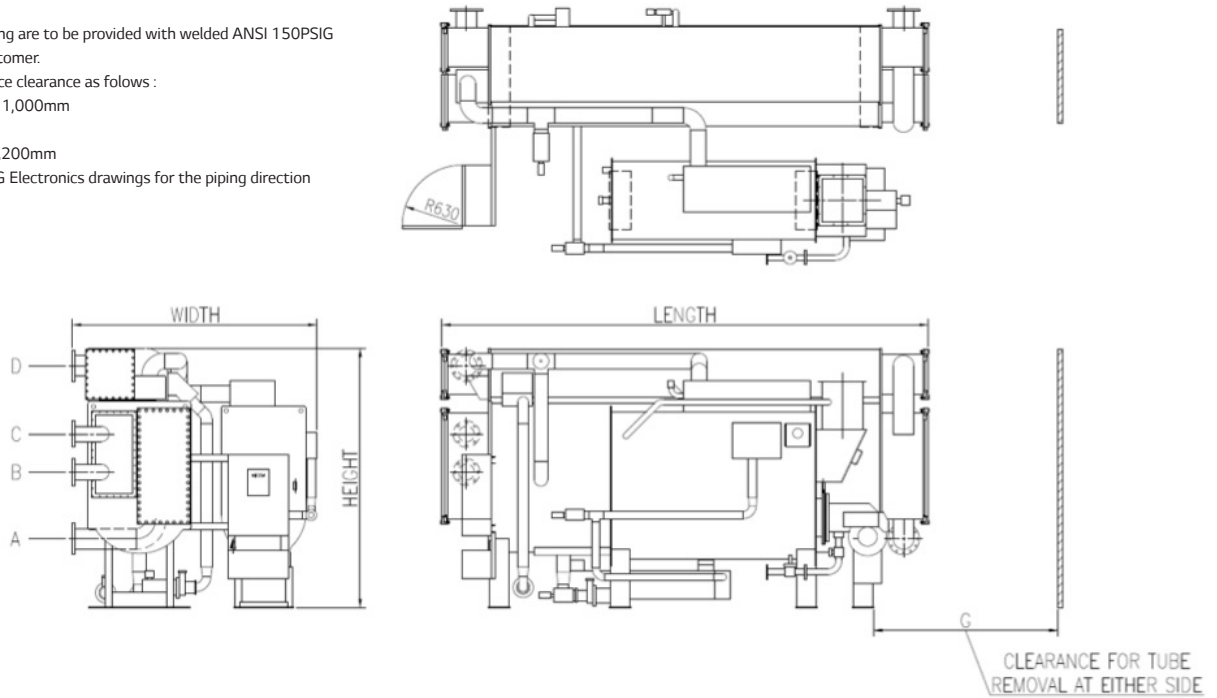

Model	Dimension(mm)			Nozzle connection (B)				Clearance (mm)
	Length	Width	Height	A	B	C	D	G
WCDN005	2,205	1,685	1,760	4	3	3	4	1,700
WCDN006	2,205	1,685	1,760	4	3	3	4	1,700
WCDN007	2,555	1,860	1,760	4	3	3	4	2,200
WCDN008	2,555	1,860	1,760	4	3	3	4	2,200
WCDN010	3,165	2,000	2,070	5	4	4	5	2,400
WCDN012	3,165	2,045	2,070	5	4	4	5	2,400
WCDN015	3,745	2,095	2,070	5	4	4	5	3,400
WCDN018	3,665	2,095	2,070	5	4	4	5	3,400
WCDN021	3,705	2,150	2,415	6	5	5	6	3,400
WCDN024	3,795	2,170	2,415	6	5	5	6	3,400
WCDN028	4,725	2,320	2,415	8	6	6	8	4,500
WCDN032	4,725	2,260	2,415	8	6	6	8	4,500
WCDN036	4,890	2,425	2,590	8	6	6	8	4,500
WCDN040	4,890	2,545	2,590	8	6	6	8	4,500
WCDN045	4,900	2,840	2,925	10	8	8	10	4,500
WCDN050	5,205	2,840	2,925	10	8	8	10	4,500
WCDN056	5,050	3,350	3,295	12	8	8	12	4,500
WCDN063	5,495	3,150	3,295	12	8	8	12	5,200
WCDN070	6,005	3,255	3,295	12	8	8	12	5,700

WCDN

1. The foundation and the floor must be sufficiently strong to support the unit weight.
2. Provide a floor drain near chiller foundation.
3. Only if foundation anchoring is required, anchor bolts, nuts and washers, shall be supplied together with chiller. Anchor bolts must be fixed on the foundation prior to chiller installation.
4. Unit must be leveled before startup.
(Horizontal level must be below than 2mm/1,000mm)

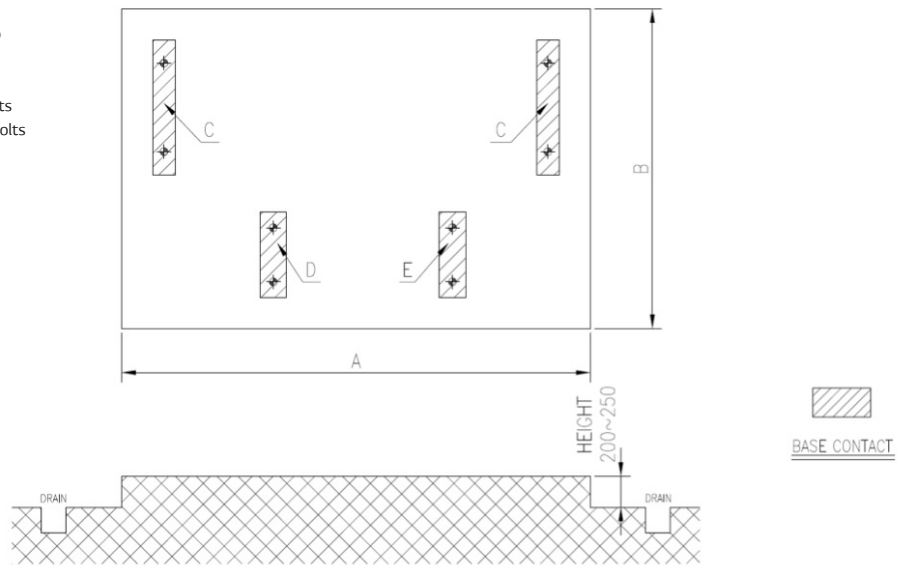

Model	Dimension(mm)		Weight (ton)			
	A	B	C	D	E	Total
WCDN005	1,868	1,333	1.2	0.5	0.3	3.2
WCDN006	1,868	1,333	1.3	0.5	0.3	3.4
WCDN007	2,318	1,480	1.5	0.5	0.3	3.8
WCDN008	2,318	1,480	1.5	0.6	0.4	4.0
WCDN010	2,300	2,000	1.6	0.8	1.0	4.9
WCDN012	2,300	2,100	1.8	0.8	1.0	5.2
WCDN015	3,300	2,100	2.1	0.9	1.1	6.2
WCDN018	3,300	2,100	2.4	1.0	1.2	6.8
WCDN021	3,300	2,150	2.7	1.2	1.4	8.0
WCDN024	3,300	2,150	2.9	1.2	1.4	8.5
WCDN028	4,500	2,250	3.8	1.2	1.4	10.2
WCDN032	4,500	2,250	4.0	1.3	1.5	10.9
WCDN036	4,500	2,650	4.4	1.6	2.0	12.4
WCDN040	4,500	2,650	4.8	1.7	2.1	13.3
WCDN045	4,500	3,000	5.6	2.0	2.4	15.6
WCDN050	4,500	3,000	6.4	2.1	2.5	17.4
WCDN056	4,500	3,300	7.7	2.7	3.1	21.3
WCDN063	5,500	3,300	9.1	3.0	3.4	24.5
WCDN070	5,500	3,300	10.3	3.3	3.7	27.6

WCDS

- All external water piping are to be provided with welded ANSI 150PSIG RF flanges by the customer.
- Installation and service clearance as follows :
 Logitudinal distance - 1,000mm
 Top - 200mm
 Control panel side - 1,200mm
- Please refer to the LG Electronics drawings for the piping direction

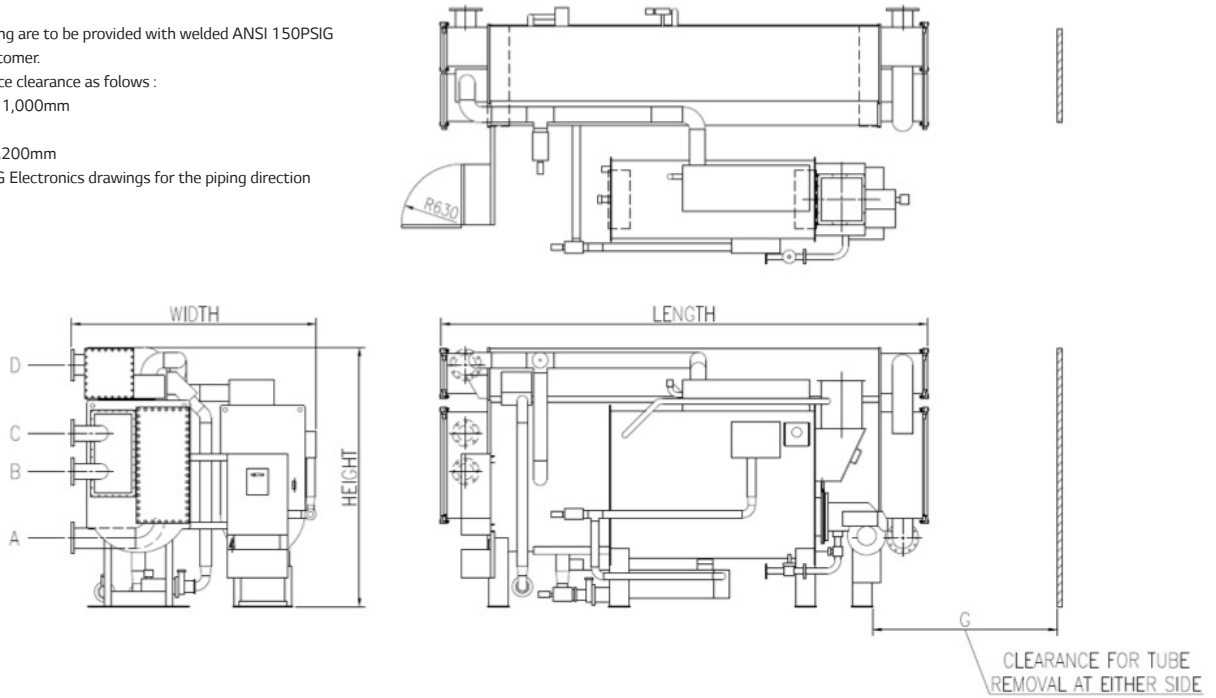

Model	Dimension(mm)			Nozzle connection (B)				Clearance (mm)
	Length	Width	Height	A	B	C	D	
WCDS010S	2,700	1,990	2,030	5	4	4	5	2,400
WCDS012S	2,700	1,990	2,030	5	4	4	5	2,400
WCDS015S	3,720	1,990	2,030	5	4	4	5	3,400
WCDS018S	3,720	2,010	2,030	5	4	4	5	3,400
WCDS021S	3,740	2,190	2,300	6	5	5	6	3,400
WCDS024S	3,740	2,210	2,300	6	5	5	6	3,400
WCDS028S	4,780	2,170	2,300	8	6	6	8	4,500
WCDS032S	4,780	2,170	2,300	8	6	6	8	4,500
WCDS036S	4,890	2,310	2,540	8	6	6	8	4,500
WCDS040S	4,890	2,350	2,540	8	6	6	8	4,500
WCDS045S	4,870	2,570	2,765	10	8	8	10	4,500
WCDS050S	4,870	2,570	2,765	10	8	8	10	4,500
WCDS056S	5,060	3,080	3,255	12	8	8	12	4,600
WCDS063S	5,600	3,080	3,255	12	8	8	12	5,200
WCDS070S	6,100	3,080	3,255	12	8	8	12	5,700
WCDS080S	5,740	3,400	3,600	14	10	10	14	5,200
WCDS090S	6,240	3,400	3,600	14	10	10	14	5,700
WCDS100S	6,760	3,400	3,600	14	10	10	14	6,200

WCDS

1. All external water piping are to be provided with welded ANSI 150PSIG RF flanges by the customer.
2. Installation and service clearance as follows :
 Logitudinal distance - 1,000mm
 Top - 200mm
 Control panel side - 1,200mm
3. Please refer to the LG Electronics drawings for the piping direction

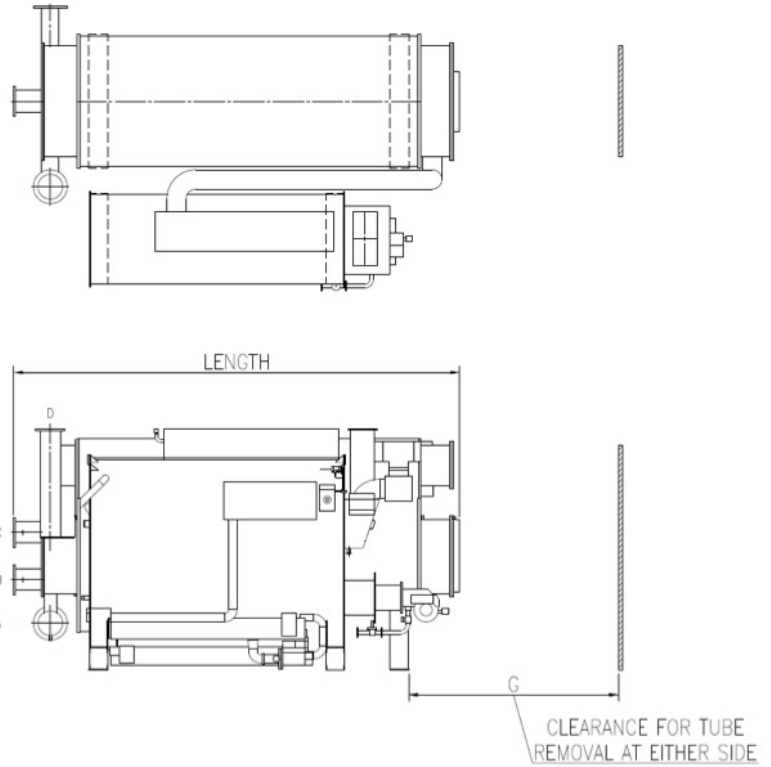

Model	Dimension(mm)			Nozzle connection (B)				Clearance (mm)
	Length	Width	Height	A	B	C	D	G
WCDS110S	6,170	4,180	3,600	16	12	12	16	5,700
WCDS120S	6,690	4,180	3,600	16	12	12	16	6,200
WCDS130S	7,190	4,180	3,600	16	12	12	16	6,700
WCDS140S	6,850	4,590	3,800	16	14	14	16	6,200
WCDS150S	7,350	4,590	3,800	16	14	14	16	6,200

WCDS

1. The foundation and the floor must be sufficiently strong to support the unit weight.
2. Provide a floor drain near chiller foundation.
3. Only if foundation anchoring is required, anchor bolts, nuts and washers, shall be supplied together with chiller. Anchor bolts must be fixed on the foundation prior to chiller installation.
4. Unit must be leveled before startup.
(Horizontal level must be below than 2mm/1,000mm)

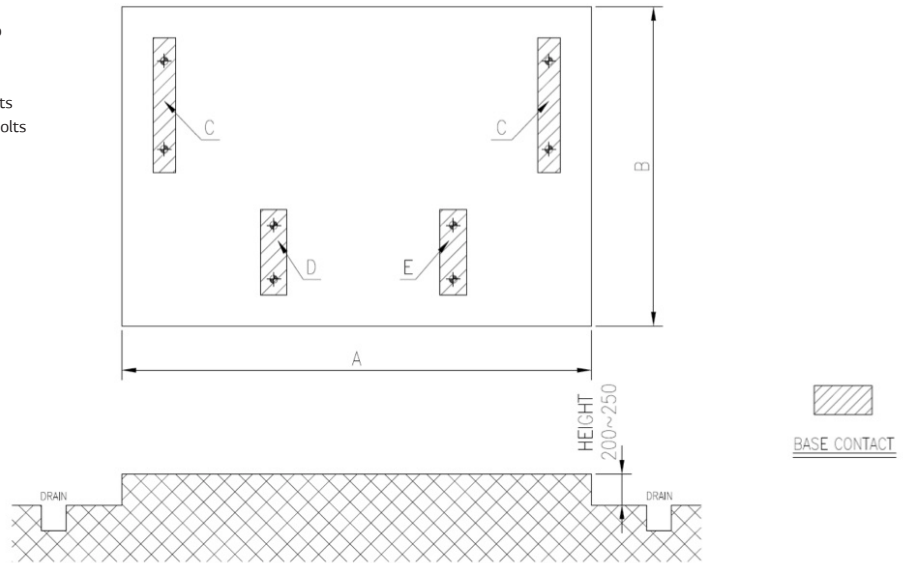

Model	Dimension(mm)		Weight (ton)			
	A	B	C	D	E	Total
WCDS010S	2,300	1,700	1.6	0.7	0.9	4.8
WCDS012S	2,300	1,700	1.7	0.8	0.9	5.1
WCDS015S	3,300	1,800	2.1	0.9	1.0	6.1
WCDS018S	3,300	1,800	2.3	1.0	1.1	6.7
WCDS021S	3,300	1,950	2.7	1.1	1.4	7.9
WCDS024S	3,300	1,950	2.8	1.2	1.4	8.2
WCDS028S	4,350	1,900	3.3	1.2	1.4	9.2
WCDS032S	4,350	1,900	3.5	1.3	1.5	9.8
WCDS036S	4,350	2,000	4.4	1.7	1.8	12.3
WCDS040S	4,350	2,000	4.5	1.8	1.9	12.7
WCDS045S	4,350	2,250	5.7	2.4	2.6	16.4
WCDS050S	4,350	2,250	5.8	2.8	3.0	17.4
WCDS056S	4,350	2,750	7.7	2.7	3.1	21.2
WCDS063S	4,900	2,750	8.3	3.0	3.3	22.9
WCDS070S	5,400	2,750	8.9	3.3	3.6	24.7
WCDS080S	4,900	3,100	12.4	4.1	4.6	33.5
WCDS090S	5,400	3,100	13.2	4.6	5.1	36.1
WCDS100S	5,900	3,100	14.1	5.2	5.5	38.9
WCDS110S	5,000	3,650	15.6	6.4	6.7	44.3
WCDS120S	5,500	3,650	16.7	6.9	7.3	47.6
WCDS130S	6,000	3,650	17.6	7.5	7.9	50.6
WCDS140S	5,500	4,000	19.3	8.3	8.6	55.5
WCDS150S	6,000	4,000	20.4	8.7	9.0	58.5

WCMW

- All external water piping are to be provided with welded ANSI 150PSIG RF flanges by the customer.
- Installation and service clearance as follows :
 Logitudinal distance - 1,000mm
 Top - 200mm
 Control panel side - 1,200mm
- Please refer to the LG Electronics drawings for the piping direction

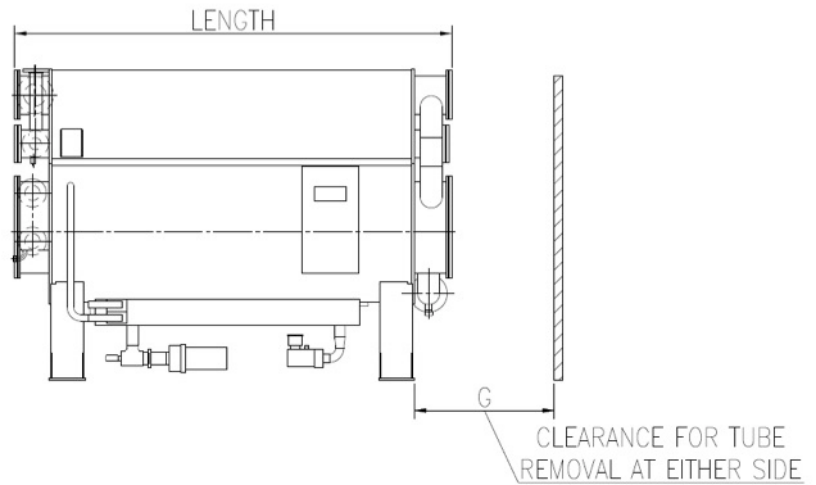
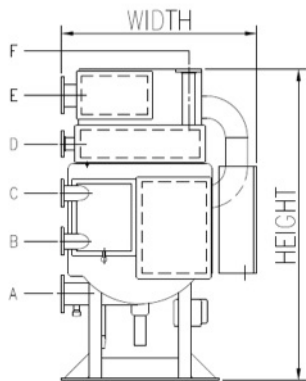
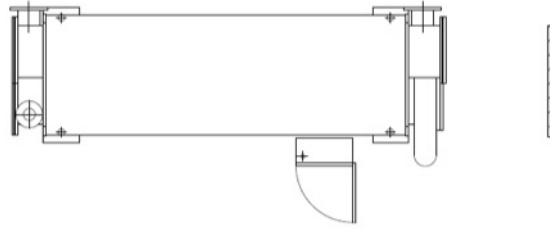

Model	Dimension(mm)			Nozzle connection (B)						Clearance (mm)
	Length	Width	Height	A	B	C	D	E	F	
WCMW003	2,020	1,394	1,952	3	2 1/2	2 1/2	1 1/2	3	1 1/2	2,000
WCMW004	2,020	1,396	1,965	3	2 1/2	2 1/2	1 1/2	3	1 1/2	2,000
WCMW005	2,520	1,396	1,965	3	2 1/2	2 1/2	2 1/2	3	2 1/2	2,400
WCMW007	2,547	1,355	2,150	5	3	3	2 1/2	5	2 1/2	2,400
WCMW008	2,547	1,355	2,150	5	3	3	2 1/2	5	2 1/2	2,400
WCMW010	3,567	1,355	2,150	5	4	4	3	5	3	3,400
WCMW012	3,567	1,355	2,150	5	4	4	3	5	3	3,400
WCMW014	3,627	1,526	2,330	6	4	4	3	6	3	3,400
WCMW016	3,627	1,526	2,330	6	4	4	3	6	3	3,400
WCMW019	4,630	1,526	2,330	8	5	5	4	8	4	4,500
WCMW021	4,630	1,526	2,330	8	5	5	4	8	4	4,500
WCMW024	4,784	1,575	2,630	8	6	6	4	8	4	4,500
WCMW027	4,784	1,575	2,630	8	6	6	4	8	4	4,500
WCMW031	4,789	1,702	2,886	10	6	6	5	10	5	4,500
WCMW034	4,789	1,702	2,886	10	6	6	5	10	5	4,500
WCMW038	4,931	1,702	3,260	12	8	8	6	12	6	4,600
WCMW043	5,473	2,015	3,260	12	8	8	6	12	6	5,200
WCMW048	5,971	2,015	3,260	12	8	8	6	12	6	5,700
WCMW054	5,616	2,195	3,680	14	8	8	8	14	8	5,200
WCMW060	6,114	2,195	3,680	14	8	8	8	14	8	5,700
WCMW067	6,639	2,195	3,680	14	8	8	8	14	8	6,200

WCMW003-WCMW021

1. The foundation and the floor must be sufficiently strong to support the unit weight.
2. Provide a floor drain near chiller foundation.
3. Only if foundation anchoring is required, anchor bolts, nuts and washers, shall be supplied together with chiller. Anchor bolts must be fixed on the foundation prior to chiller installation.
4. Unit must be leveled before startup.
(Horizontal level must be below than 2mm/1,000mm)

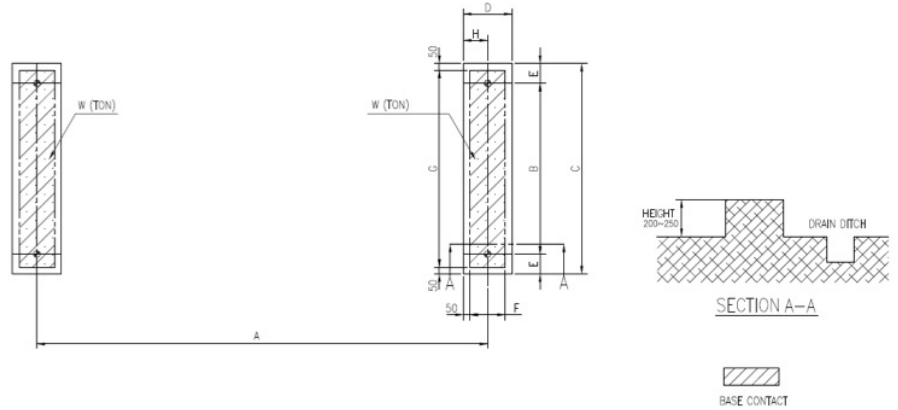

Model	Dimension(mm)								Weight(ton)
	A	B	C	D	E	F	G	H	W
WCMW003	1,471	900	1,120	195	110	95	1,020	97.5	1.10
WCMW004	1,471	900	1,120	195	110	95	1,020	97.5	1.15
WCMW005	1,971	900	1,120	195	110	95	1,020	97.5	1.35
WCMW007	1,926	820	1,120	245	150	145	1,020	125	2.05
WCMW008	1,926	820	1,120	245	150	145	1,020	125	2.15
WCMW010	2,946	820	1,120	245	150	145	1,020	125	2.65
WCMW012	2,946	820	1,120	245	150	145	1,020	125	2.85
WCMW014	2,816	980	1,280	370	150	270	1,180	185	3.45
WCMW016	2,816	980	1,280	370	150	270	1,180	185	3.60
WCMW019	3,836	980	1,280	370	150	270	1,180	185	4.20
WCMW021	3,836	980	1,280	370	150	270	1,180	185	4.45

WCMW

- All external water piping are to be provided with welded ANSI 150PSIG RF flanges by the customer.
- Installation and service clearance as follows :
 Logitudinal distance - 1,000mm
 Top - 200mm
 Control panel side - 1,200mm
- Please refer to the LG Electronics drawings for the piping direction

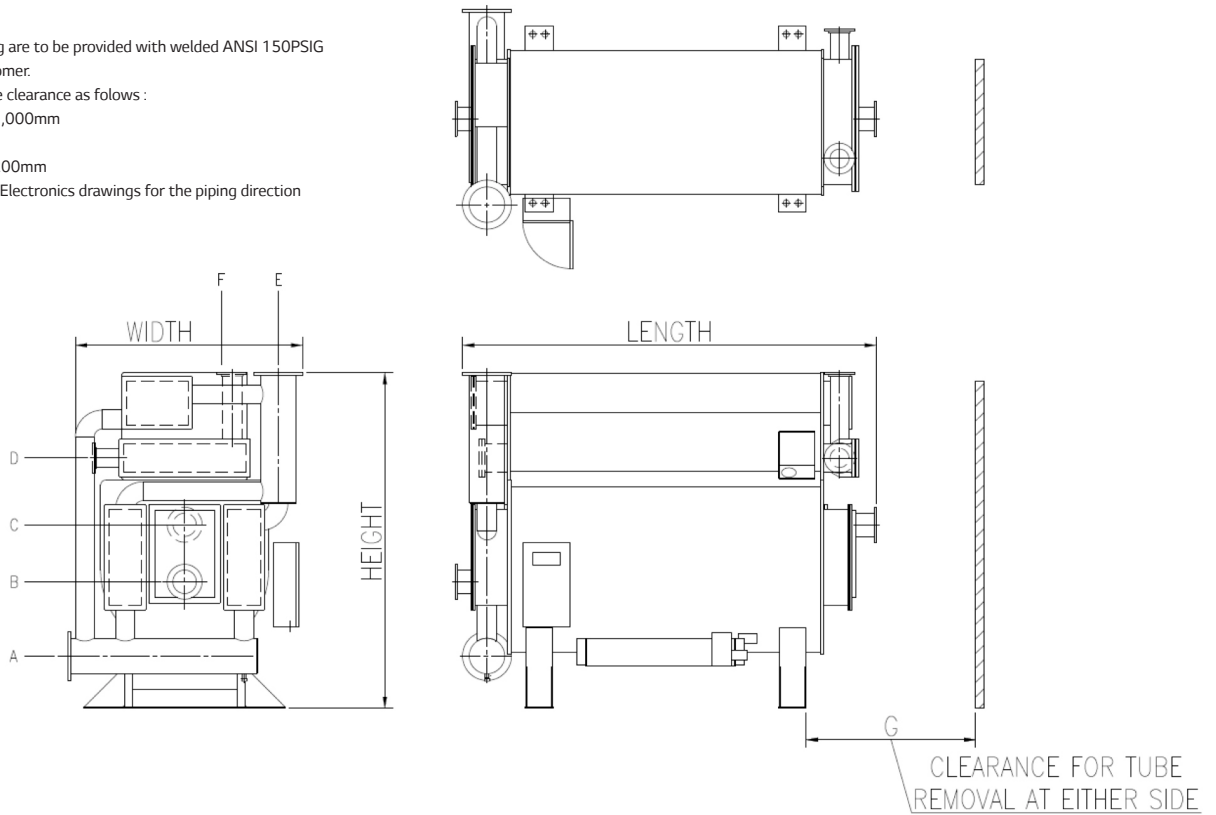

Model	Dimension(mm)			Nozzle connection (B)						Clearance (mm)
	Length	Width	Height	A	B	C	D	E	F	
WCMW074	6,346	2,680	3,920	16	10	10	8	16	8	5,800
WCMW081	6,871	2,680	3,920	16	10	10	8	16	8	6,300
WCMW088	7,371	2,680	3,920	16	10	10	8	16	8	6,800
WCMW095	7,070	2,910	4,040	16	12	12	8	16	8	6,300
WCMW102	7,570	2,910	4,040	16	12	12	8	16	8	6,800

WCMW024-WCMW102

1. The foundation and the floor must be sufficiently strong to support the unit weight.
2. Provide a floor drain near chiller foundation.
3. Only if foundation anchoring is required, anchor bolts, nuts and washers, shall be supplied together with chiller. Anchor bolts must be fixed on the foundation prior to chiller installation.
4. Unit must be leveled before startup.
(Horizontal level must be below than 2mm/1,000mm)

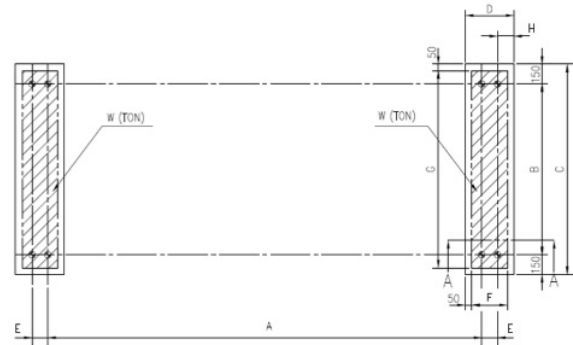

Model	Dimension(mm)								Weight(ton)
	A	B	C	D	E	F	G	H	W
WCMW024	3,716	1,040	1,340	370	120	270	1,240	125	5.40
WCMW027	3,716	1,040	1,340	370	120	270	1,240	125	5.65
WCMW031	3,716	1,160	1,460	370	120	270	1,360	125	6.70
WCMW034	3,716	1,160	1,460	370	120	270	1,360	125	7.00
WCMW038	3,706	1,600	1,900	370	130	270	1,800	120	9.65
WCMW043	4,248	1,600	1,900	370	130	270	1,800	120	10.45
WCMW048	4,746	1,600	1,900	370	130	270	1,800	120	11.00
WCMW054	4,188	1,800	2,100	420	140	320	2,000	140	13.75
WCMW060	4,686	1,800	2,100	420	140	320	2,000	140	14.75
WCMW067	5,211	1,800	2,100	420	140	320	2,000	140	15.85
WCMW074	4,286	2,100	2,400	420	140	320	2,300	140	17.85
WCMW081	4,811	2,100	2,400	420	140	320	2,300	140	19.10
WCMW088	5,311	2,100	2,400	420	140	320	2,300	140	20.25
WCMW095	4,811	2,300	2,600	420	140	320	2,500	140	22.50
WCMW102	5,311	2,300	2,600	420	140	320	2,500	140	23.70

WCSS

- All external water piping are to be provided with welded ANSI 150PSIG RF flanges by the customer.
- Installation and service clearance as follows :
 Logitudinal distance - 1,000mm
 Top - 200mm
 Control panel side - 1,200mm
- Please refer to the LG Electronics drawings for the piping direction

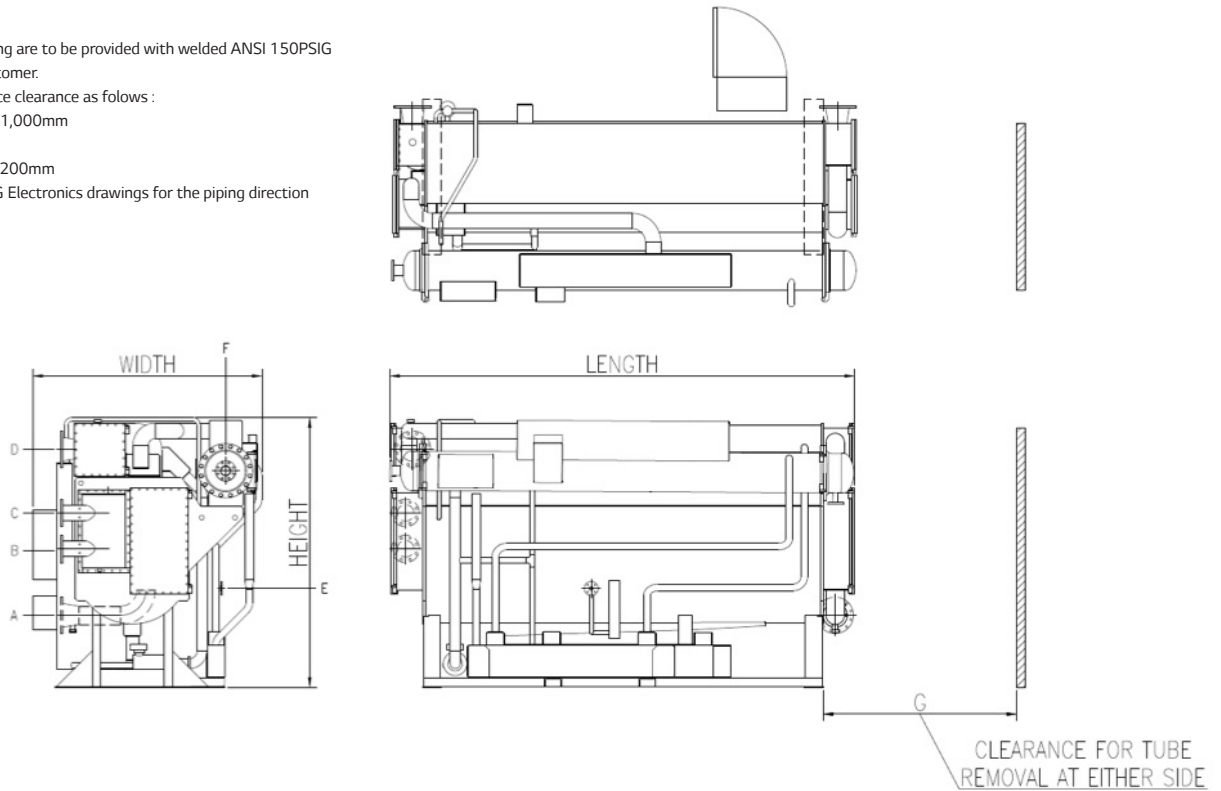

Model	Dimension(mm)			Nozzle connection (B)						Clearance (mm)
	Length	Width	Height	A	B	C	D	E	F	
WCSS010	2,650	1,800	2,150	5	4	4	5	1	2	2,400
WCSS012	2,650	1,800	2,150	5	4	4	5	1	2	2,400
WCSS015	3,670	1,800	2,150	5	4	4	5	1	2	3,400
WCSS018	3,670	1,800	2,150	5	4	4	5	1	2	3,400
WCSS021	3,730	2,030	2,450	6	5	5	6	1	2 1/2	3,400
WCSS024	3,730	2,030	2,450	6	5	5	6	1	2 1/2	3,400
WCSS028	4,750	2,030	2,450	8	6	6	8	1	2 1/2	4,500
WCSS032	4,750	2,030	2,450	8	6	6	8	1	2 1/2	4,500
WCSS036	4,850	2,110	2,650	8	6	6	8	1 1/2	3	4,500
WCSS040	4,850	2,110	2,650	8	6	6	8	1 1/2	3	4,500
WCSS045	4,850	2,350	2,900	10	8	8	10	1 1/2	3	4,500
WCSS050	4,850	2,350	2,900	10	8	8	10	1 1/2	3	4,500
WCSS056	5,060	2,500	3,255	12	8	8	12	2	4	4,600
WCSS063	5,600	2,500	3,255	12	8	8	12	2	4	5,200
WCSS070	6,100	2,500	3,255	12	8	8	12	2	4	5,700
WCSS080	5,710	2,850	3,580	14	10	10	14	2 1/2	5	5,200
WCSS090	6,210	2,850	3,580	14	10	10	14	2 1/2	5	5,700
WCSS100	6,730	2,850	3,580	14	10	10	14	2 1/2	5	6,200

WCSS010~WCSS032 WCSS036~WCSS150

1. The foundation and the floor must be sufficiently strong to support the unit weight.
2. Provide a floor drain near chiller foundation.
3. Only if foundation anchoring is required, anchor bolts, nuts and washers, shall be supplied together with chiller. Anchor bolts must be fixed on the foundation prior to chiller installation.
4. Unit must be leveled before startup.
(Horizontal level must be below than 2mm/1,000mm)

WCSS010~WCSS032

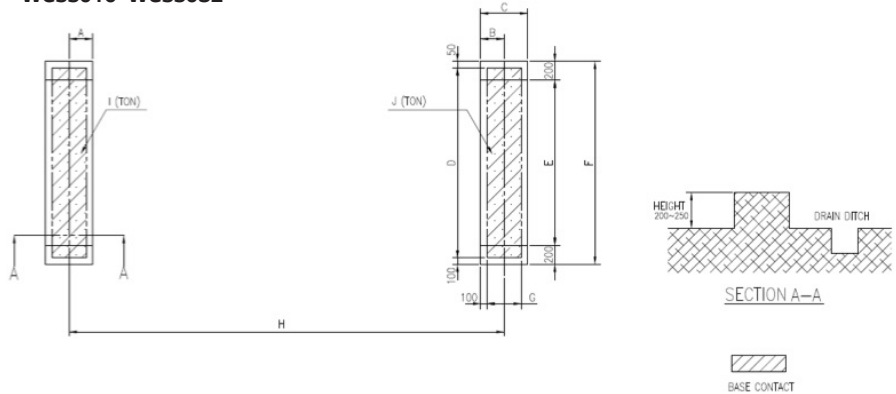

WCSS036~WCSS150

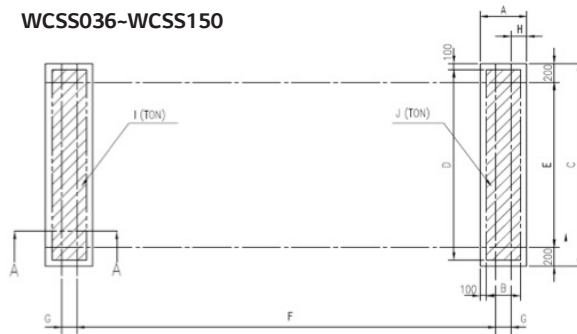

Model	Dimension(mm)									Weight(ton)	
	A	B	C	D	E	F	G	H	I	J	
WCSS010	210	210	420	1,160	960	1,360	220	1,846	2.3	2.3	
WCSS012	210	210	420	1,160	960	1,360	220	1,846	2.4	2.4	
WCSS015	210	210	420	1,160	960	1,360	220	2,866	3.0	3.0	
WCSS018	210	210	420	1,160	960	1,360	220	2,866	3.1	3.1	
WCSS021	235	235	470	1,460	1,260	1,660	270	2,816	3.7	3.7	
WCSS024	235	235	470	1,460	1,260	1,660	270	2,816	3.9	3.9	
WCSS028	235	235	470	1,460	1,260	1,660	270	3,836	4.5	4.5	
WCSS032	235	235	470	1,460	1,260	1,660	270	3,836	4.8	4.8	
WCSS036	470	270	1,760	1,560	1,360	3,716	120	175	5.8	5.8	
WCSS040	470	270	1,760	1,560	1,360	3,716	120	175	6.0	6.0	
WCSS045	470	270	1,860	1,660	1,460	3,716	120	175	7.1	7.1	
WCSS050	470	270	1,860	1,660	1,460	3,716	120	175	7.4	7.4	
WCSS056	470	270	2,060	1,860	1,660	3,706	130	170	9.8	9.8	
WCSS063	470	270	2,060	1,860	1,660	4,248	130	170	10.7	10.7	
WCSS070	470	270	2,060	1,860	1,660	4,746	130	170	11.5	11.5	
WCSS080	520	320	2,300	2,100	1,900	4,188	140	190	14.7	14.7	
WCSS090	520	320	2,300	2,100	1,900	4,686	140	190	15.8	15.8	
WCSS100	520	320	2,300	2,100	1,900	5,211	140	190	17.0	17.0	
WCSS110	520	320	2,500	2,300	2,100	4,286	140	190	18.9	18.9	
WCSS120	520	320	2,500	2,300	2,100	4,811	140	190	20.2	20.2	
WCSS130	520	320	2,500	2,300	2,100	5,311	140	190	21.4	21.4	
WCSS140	520	320	2,700	2,500	2,300	4,811	140	190	23.6	23.6	
WCSS150	520	320	2,700	2,500	2,300	5,311	140	190	25.0	25.0	

WCSS

1. All external water piping are to be provided with welded ANSI 150PSIG RF flanges by the customer.
2. Installation and service clearance as follows :
 Logitudinal distance - 1,000mm
 Top - 200mm
 Control panel side - 1,200mm
3. Please refer to the LG Electronics drawings for the piping direction

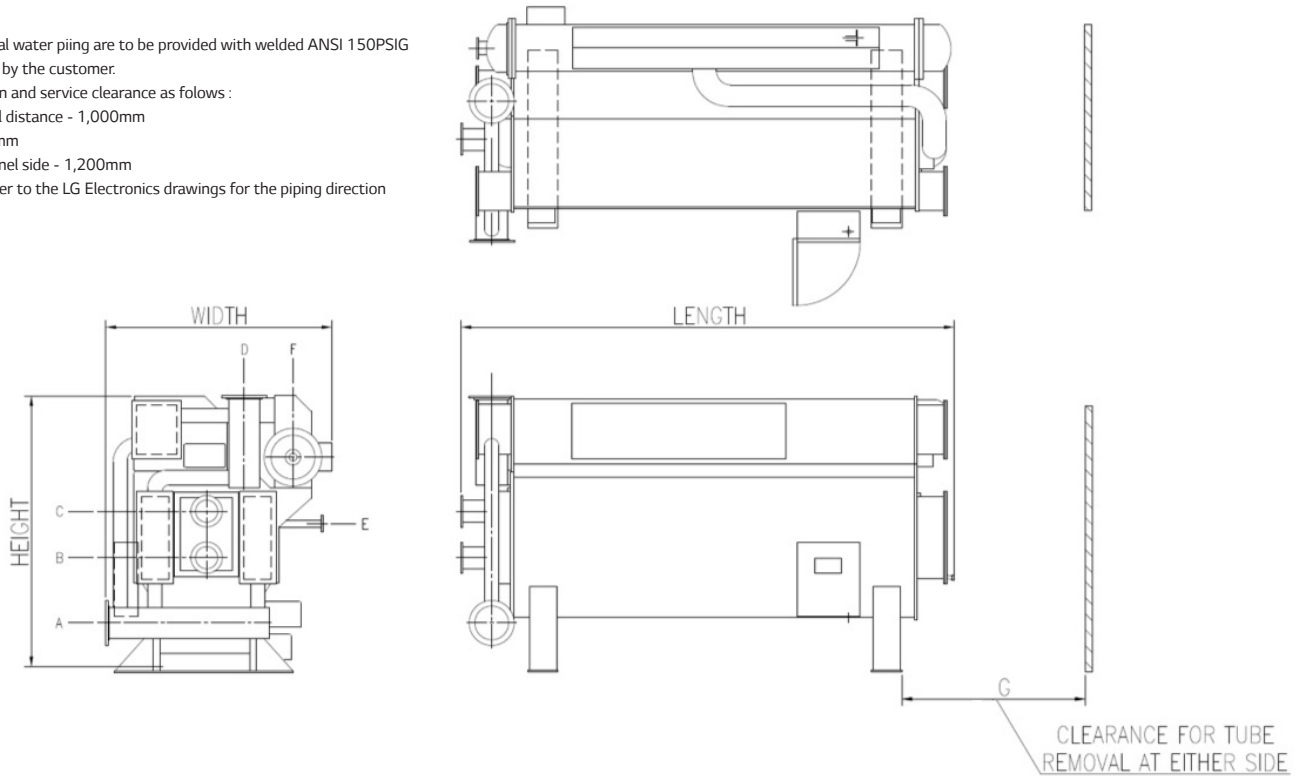

Model	Dimension(mm)			Nozzle connection (B)						Clearance (mm)
	Length	Width	Height	A	B	C	D	E	F	
WCSS110	6,170	3,000	3,750	16	12	12	16	3	6	5,800
WCSS120	6,690	3,000	3,750	16	12	12	16	3	6	6,300
WCSS130	7,180	3,000	3,750	16	12	12	16	3	6	6,800
WCSS140	6,830	3,500	3,950	16	14	14	16	3	6	6,300
WCSS150	7,330	3,500	3,950	16	14	14	16	3	6	6,800

WCSH

- All external water piping are to be provided with welded ANSI 150PSIG RF flanges by the customer.
- Installation and service clearance as follows :
 - Logitudinal distance - 1,000mm
 - Top - 200mm
 - Control panel side - 1,200mm
- Please refer to the LG Electronics drawings for the piping direction

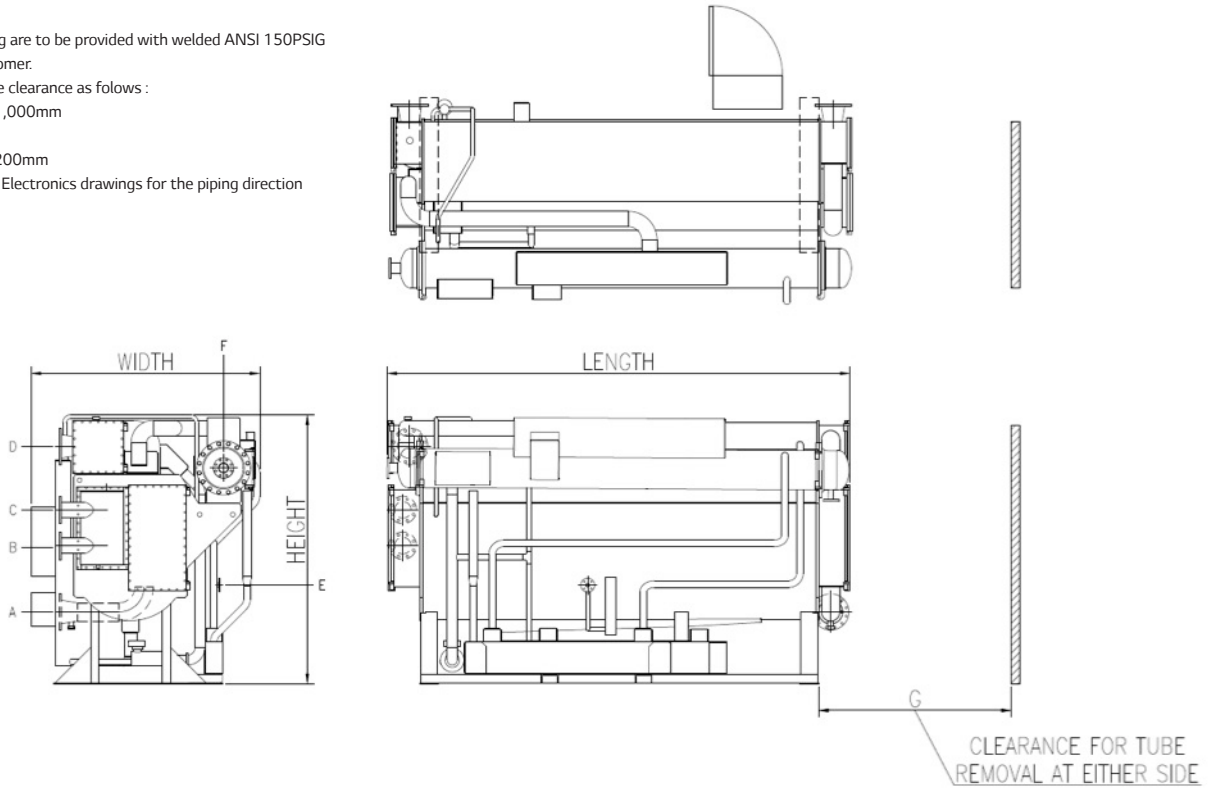

Model	Dimension(mm)			Nozzle connection (B)						Clearance (mm)
	Length	Width	Height	A	B	C	D	E	F	
WCSH010	2,730	1,810	2,065	5	4	4	5	1	2	2,400
WCSH012	2,730	1,810	2,065	5	4	4	5	1	2	2,400
WCSH015	3,720	1,810	2,070	5	4	4	5	1	2	3,400
WCSH018	3,720	1,810	2,110	5	4	4	5	1	2	3,400
WCSH021	3,720	2,000	2,415	6	5	5	6	1	2	3,400
WCSH024	3,720	2,000	2,415	6	5	5	6	1	2	3,400
WCSH028	4,740	2,070	2,415	8	6	6	8	1	2 1/2	4,500
WCSH032	4,740	2,070	2,415	8	6	6	8	1	2 1/2	4,500
WCSH036	4,800	2,200	2,590	8	6	6	8	1 1/2	2	4,500
WCSH040	4,800	2,200	2,590	8	6	6	8	1 1/2	2	4,500
WCSH045	4,815	2,385	2,950	10	8	8	10	1 1/2	2	4,500
WCSH050	4,815	2,385	2,950	10	8	8	10	1 1/2	2	4,500
WCSH056	5,030	2,620	3,300	12	8	8	12	2	4	4,500
WCSH063	5,520	2,620	3,300	12	8	8	12	2	4	5,200
WCSH070	6,010	2,620	3,300	12	8	8	12	2	4	5,700

WCSH

1. All external water piping are to be provided with welded ANSI 150PSIG RF flanges by the customer.
2. Installation and service clearance as follows :
 Logitudinal distance - 1,000mm
 Top - 200mm
 Control panel side - 1,200mm
3. Please refer to the LG Electronics drawings for the piping direction

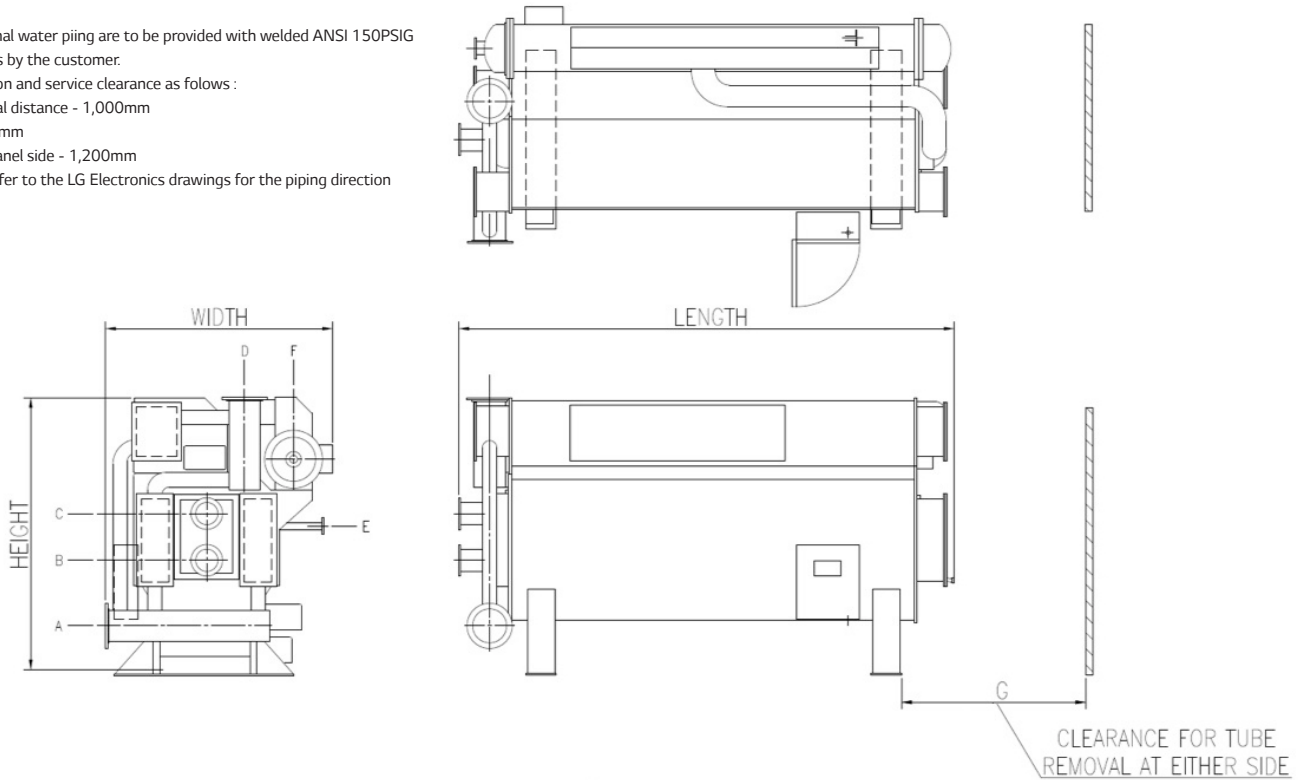

Model	Dimension(mm)			Nozzle connection (B)						Clearance (mm)
	Length	Width	Height	A	B	C	D	E	F	
WCSH080	5,635	3,090	3,550	14	10	10	14	2 1/2	5	5,200
WCSH090	6,130	3,090	3,550	14	10	10	14	2 1/2	5	5,700
WCSH100	6,590	3,090	3,550	14	10	10	14	2 1/2	5	6,200
WCSH110	6,060	3,180	3,820	16	12	12	16	3	6	5,700
WCSH120	6,580	3,180	3,820	16	12	12	16	3	6	6,200
WCSH130	7,080	3,180	3,820	16	12	12	16	3	6	6,700
WCSH140	6,640	3,520	3,840	16	14	14	16	3	6	6,200
WCSH150	7,140	3,520	3,840	16	14	14	16	3	6	6,700

WCSH

1. The foundation and the floor must be sufficiently strong to support the unit weight.
2. Provide a floor drain near chiller foundation.
3. Only if foundation anchoring is required, anchor bolts, nuts and washers, shall be supplied together with chiller. Anchor bolts must be fixed on the foundation prior to chiller installation.
4. Unit must be leveled before startup.
(Horizontal level must be below than 2mm/1,000mm)

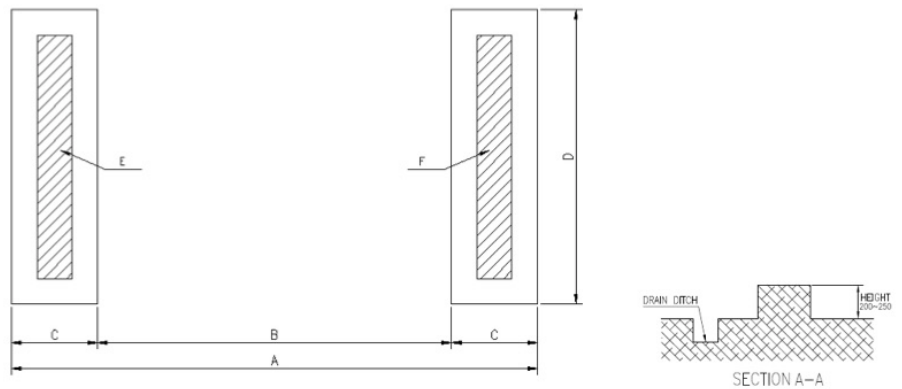

Model	Dimension(mm)		Weight (ton)				
	A	B	C	D	E	F	Total
WCSH010	2,466	1,326	570	1,500	2.3	2.2	4.5
WCSH012	2,466	1,326	570	1,500	2.5	2.5	5.0
WCSH015	3,486	2,346	570	1,500	3.0	3.0	6.0
WCSH018	3,486	2,346	570	1,500	3.3	3.2	6.5
WCSH021	3,486	2,346	570	1,800	3.8	3.8	7.6
WCSH024	3,486	2,346	570	1,800	4.1	4.0	8.1
WCSH028	4,506	3,366	570	1,800	4.9	4.9	9.8
WCSH032	4,506	3,366	570	1,800	5.2	5.1	10.3
WCSH036	4,506	3,166	670	1,900	6.0	5.9	11.9
WCSH040	4,506	3,166	670	1,900	6.6	6.5	13.1
WCSH045	4,506	3,166	670	2,000	7.7	7.6	15.3
WCSH050	4,506	3,166	670	2,000	8.4	8.4	16.8
WCSH056	4,506	3,166	670	2,300	10.1	10.1	20.2
WCSH063	5,048	3,708	670	2,300	11.9	11.9	23.8
WCSH070	5,546	4,206	670	2,300	13.4	13.4	26.8
WCSH080	5,048	3,608	720	2,660	15.4	15.4	30.9
WCSH090	5,546	4,106	720	2,660	16.5	16.4	32.9
WCSH100	6,071	4,631	720	2,660	17.9	17.9	35.8
WCSH110	5,546	4,106	720	2,780	19.4	19.4	38.8
WCSH120	6,071	4,631	720	2,780	21.1	21.1	42.2
WCSH130	6,571	5,131	720	2,780	22.9	22.9	45.8
WCSH140	6,071	4,631	720	3,020	24.7	24.7	49.4
WCSH150	6,571	5,131	720	3,020	26.4	26.4	52.8

WCPX - Steam

- All external water piping are to be provided with welded ANSI 150PSIG RF flanges by the customer.
- Installation and service clearance as follows :
 Logitudinal distance - 1,000mm
 Top - 200mm
 Control panel side - 1,200mm
- Please refer to the LG Electronics drawings for the piping direction

- A : Hot Water Inlet
- B : Waste Heat Source Input
- C : Waste Heat Source Output
- D : Hot Water Outlet
- F : Clearance

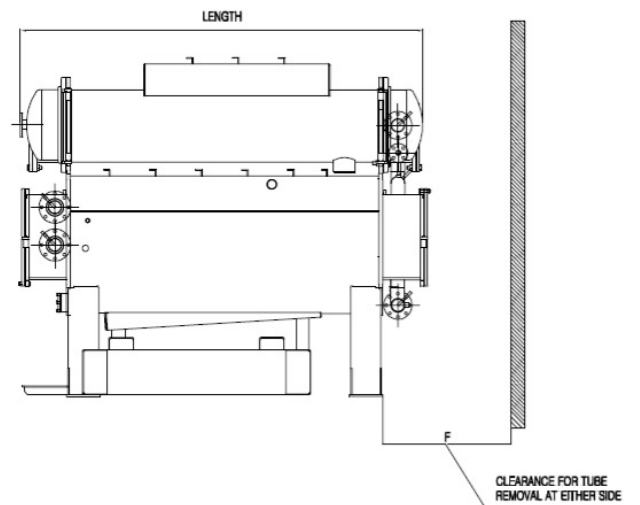
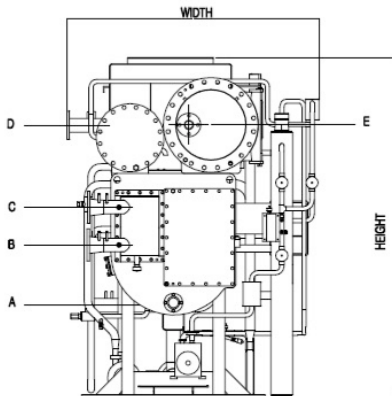
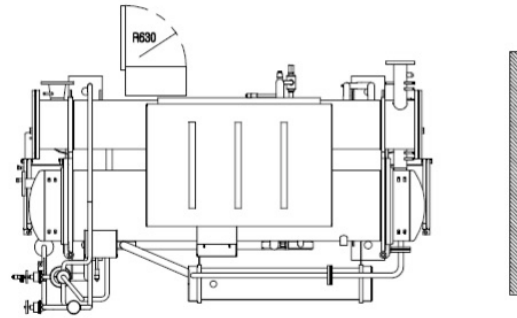

Model	Hot Water Capacity 10 ⁴ kcal/h	Dimension(mm)			Nozzle connection (B)					Clearance (mm)
		Length	Width	Heght	A	B	C	D	E	
WCPX003	30	2,180	1,400	2,090	40	65	65	40	40	2,000
WCPX007	70	2,680	1,460	2,210	65	100	100	65	50	2,400
WCPX010	100	2,680	1,460	2,210	65	100	100	65	65	2,400
WCPX015	150	3,700	1,460	2,350	65	100	100	65	65	3,400
WCPX020	200	3,760	1,630	2,600	80	125	125	80	80	3,400
WCPX026	260	4,780	1,630	2,600	100	150	150	100	100	4,500
WCPX033	330	4,880	1,680	2,960	100	150	150	100	100	4,500
WCPX040	400	4,880	1,810	3,270	125	200	200	125	125	4,500
WCPX052	520	5,630	2,120	3,800	125	200	200	125	150	5,200
WCPX066	660	5,740	2,300	4,000	150	250	250	150	200	5,200
WCPX082	820	6,760	2,300	4,000	150	250	250	150	200	6,200

WCPX - Steam

- All external water piping are to be provided with welded ANSI 150PSIG RF flanges by the customer.
- Installation and service clearance as follows :
 Logitudinal distance - 1,000mm
 Top - 200mm
 Control panel side - 1,200mm
- Please refer to the LG Electronics drawings for the piping direction

- A : Hot Water Inlet
- B : Waste Heat Source Input
- C : Waste Heat Source Output
- D : Hot Water Outlet
- F : Clearance

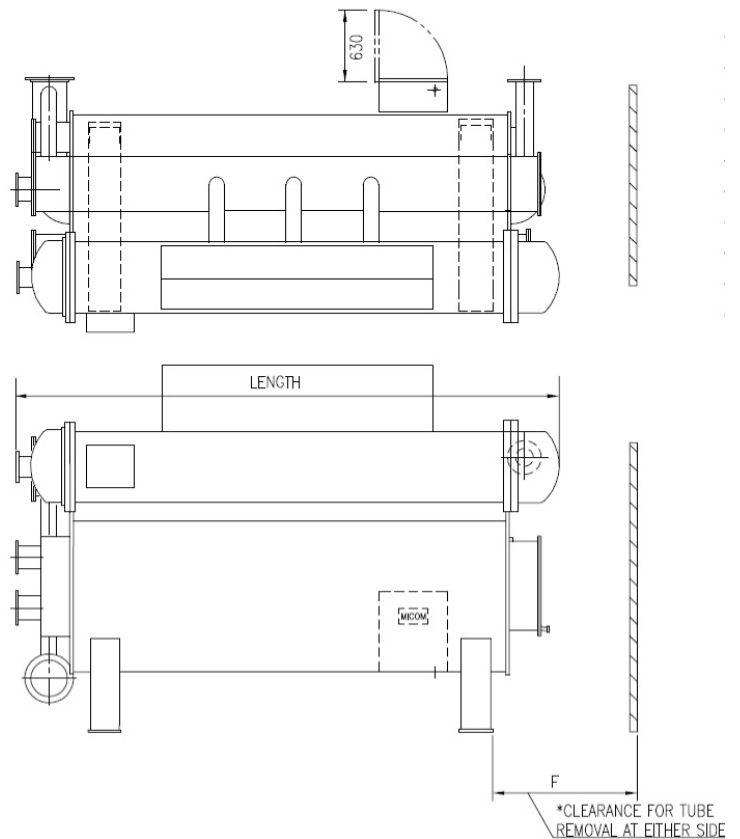
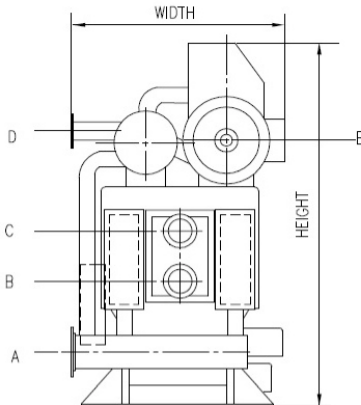

Model	Hot Water Capacity 10 ⁴ kcal/h	Dimension(mm)			Nozzle connection (B)					Clearance (mm)
		Length	Width	Heght	A	B	C	D	E	
WCPX098	980	6,720	2,780	4,200	200	300	300	200	200	6,200
WCPX115	1,150	6,860	3,010	4,300	200	350	350	200	250	6,200
WCPX130	1,300	7,370	3,240	4,400	250	400	400	250	250	6,800
WCPX147	1,470	8,170	3,240	4,400	250	400	400	250	250	7,600
WCPX163	1,630	8,970	3,240	4,400	250	400	400	250	250	8,400

WCPX - Steam

- All external water piping are to be provided with welded ANSI 150PSIG RF flanges by the customer.
- Installation and service clearance as follows :
 Logitudinal distance - 1,000mm
 Top - 200mm
 Control panel side - 1,200mm
- Please refer to the LG Electronics drawings for the piping direction

- A : Hot Water Inlet
- B : Waste Heat Source Input
- C : Waste Heat Source Ouput
- D : Hot Water Outlet
- F : Clearance

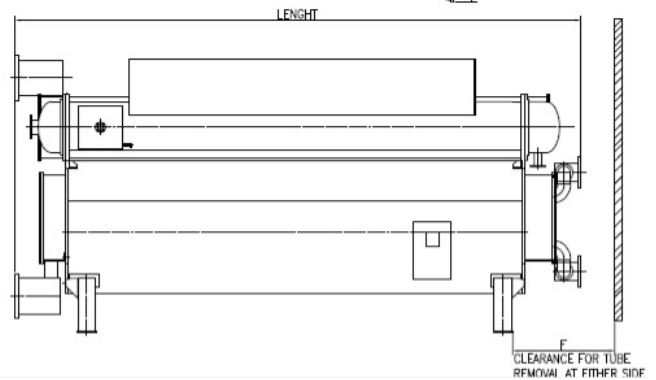
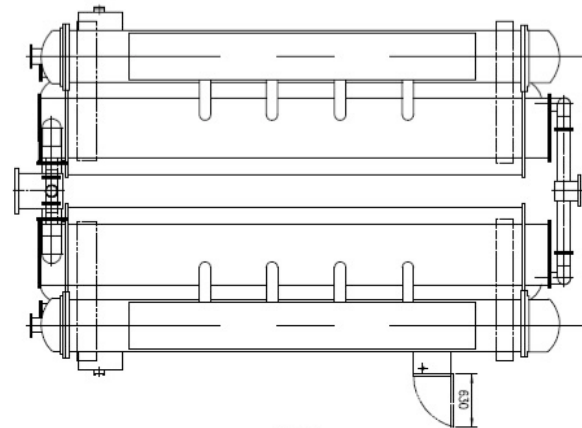
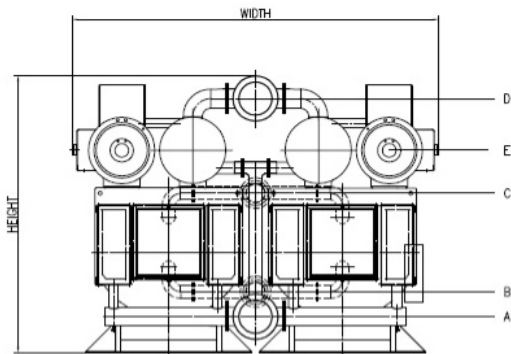

Model	Hot Water Capacity 10 ⁴ kcal/h	Dimension(mm)			Nozzle connection (B)					Clearance (mm)
		Length	Width	Heght	A	B	C	D	E	
WCPX196	1,960	6,720	5,460	4,300	300	400	400	300	200x2	6,200
WCPX230	2,300	6,860	5,920	4,400	350	450	450	350	250x2	6,200
WCPX260	2,600	7,370	6,380	4,400	350	500	500	350	250x2	6,800

WCPX - Direct Fired

- All external water piping are to be provided with welded ANSI 150PSIG RF flanges by the customer.
- Installation and service clearance as follows :
 Logitudinal distance - 1,000mm
 Top - 200mm
 Control panel side - 1,200mm
- Please refer to the LG Electronics drawings for the piping direction

- A : Hot Water Inlet
- B : Waste Heat Source Input
- C : Waste Heat Source Output
- D : Hot Water Outlet
- F : Clearance

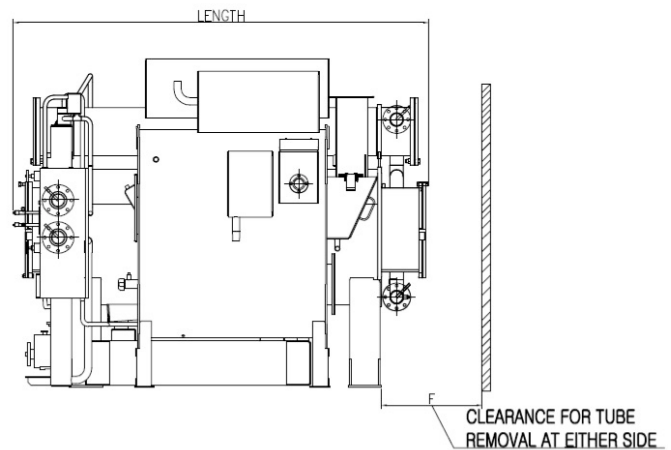
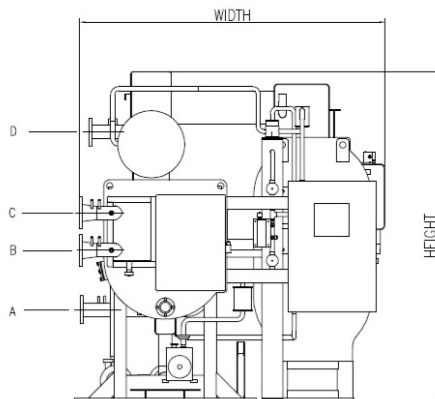
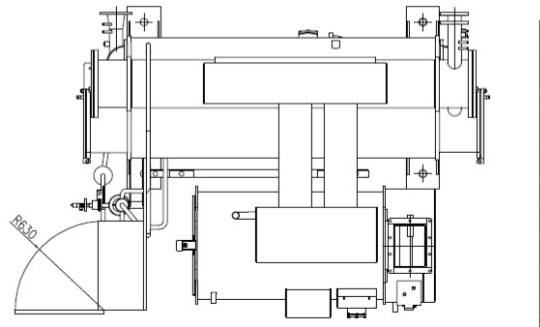

Model	Hot Water Capacity 10 ⁴ kcal/h	Dimension(mm)			Nozzle connection (B)				Clearance (mm)
		Length	Width	Heght	A	B	C	D	
WCPX003	30	2,620	2,140	2,030	40	65	65	40	2,000
WCPX007	70	3,120	2,190	2,060	65	100	100	65	2,400
WCPX010	100	3,120	2,190	2,060	65	100	100	65	2,400
WCPX015	150	3,990	2,190	2,120	65	100	100	65	3,400
WCPX020	200	4,020	2,540	2,390	80	125	125	80	3,400
WCPX026	260	4,820	2,560	2,610	100	150	150	100	4,500
WCPX033	330	4,940	2,830	3,030	100	150	150	100	4,500
WCPX040	400	5,080	3,010	3,030	125	200	200	125	4,500
WCPX052	520	6,080	3,500	3,650	125	200	200	125	5,200
WCPX066	660	6,710	4,020	3,650	150	250	250	150	5,200
WCPX082	820	7,810	4,070	3,680	150	250	250	150	6,200

WCPX003~WCPX163

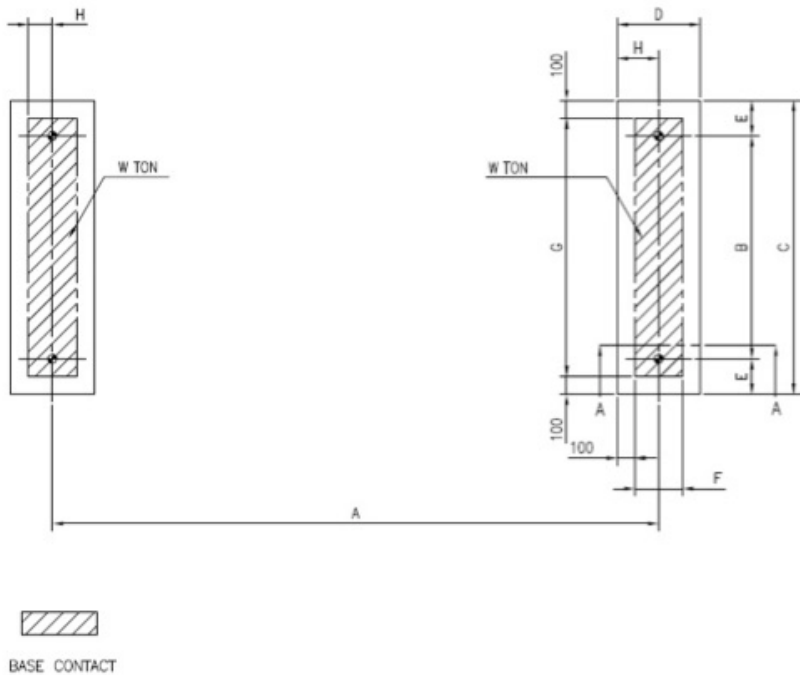

NOTE.

1. ◆ INDICATES THE POSITION OF ANCHOR BOLTS.
2. THE FOUNDATION AND THE FLOOR MUST BE SUFFICIENTLY STRONG TO SUPPORT THE UNIT WEIGHT.
3. PROVIDE A FLOOR DRAIN NEAR CHILLER FOUNDATION.
4. ONLY IF FOUNDATION ANCHORING IS REQUIRED, ANCHOR BOLTS, NUTS AND WASHERS, SHALL BE SUPPLIED TOGETHER WITH CHILLER. ANCHOR BOLTS MUST BE FIXED ON THE FOUNDATION PRIOR TO CHILLER INSTALLATION.
5. UNIT MUST BE LEVELED BEFORE STARTUP.
(HORIZONTAL LEVEL MUST BE BELOW THAN 2mm/1000mm)

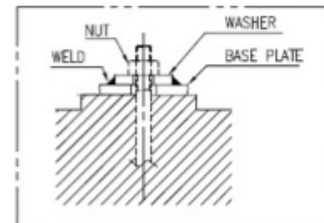
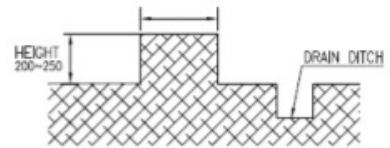

Model	Hot Water Capacity 10 ⁴ kcal/h	Dimension(mm)								
		A	B	C	D	E	F	G	H	W(ton)
WCPX003	30	1,470	820	1,140	295	160	95	940	147.5	1.5
WCPX007	70	1,926	820	1,220	345	200	145	1,020	172.5	2.3
WCPX010	100	1,926	820	1,220	345	200	145	1,020	172.5	2.5
WCPX015	150	2,946	820	1,220	345	200	145	1,020	172.5	3.2
WCPX020	200	2,816	980	1,380	470	200	270	1,180	235	4.2
WCPX026	260	3,836	980	1,380	470	200	270	1,180	235	5.2
WCPX033	330	3,836	1,040	1,440	470	200	270	1,240	235	6.5
WCPX040	400	3,836	1,160	1,560	470	200	270	1,360	235	8.0
WCPX052	520	4,378	1,600	2,000	470	200	270	1,800	235	11.9
WCPX066	660	4,328	1,800	2,200	520	200	320	2,000	260	15.3
WCPX082	820	5,351	1,800	2,200	520	200	320	2,000	260	17.5
WCPX098	980	4,951	2,100	2,500	520	200	320	2,300	260	20.7
WCPX115	1,150	4,951	2,300	2,700	520	200	320	2,500	260	24.1
WCPX130	1,300	5,461	2,500	2,900	520	200	320	2,700	260	27.9
WCPX147	1,470	6,261	2,500	2,900	520	200	320	2,700	260	29.7
WCPX163	1,630	7,061	2,500	2,900	520	200	320	2,700	260	31.5

WCPX003 ~ WCPX163

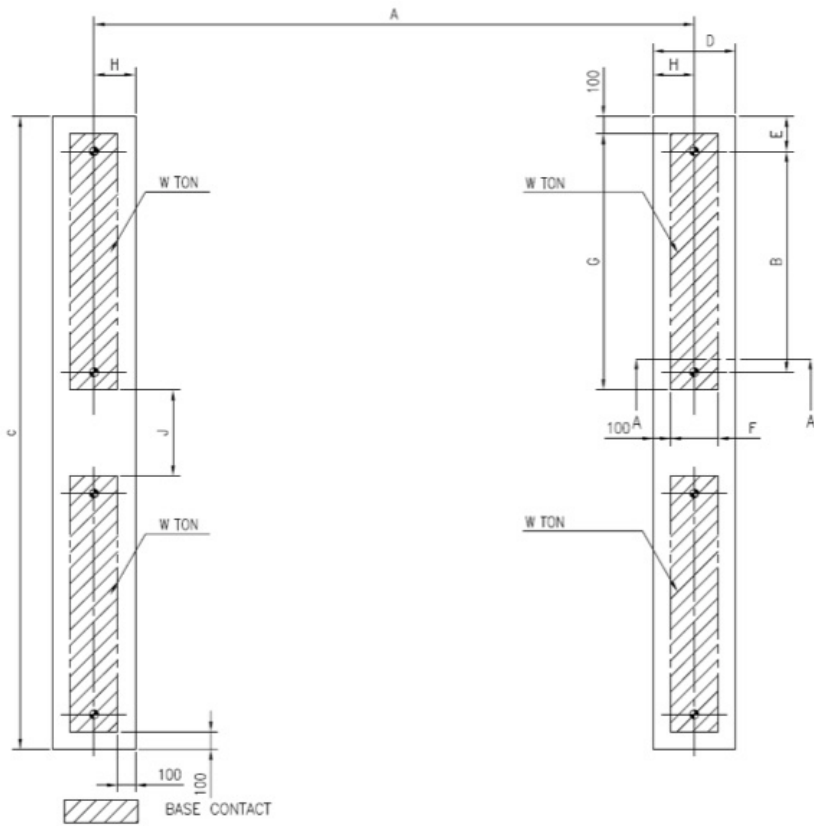

- NOTE.
- ◆ INDICATES THE POSITION OF ANCHOR BOLTS.
 - THE FOUNDATION AND THE FLOOR MUST BE SUFFICIENTLY STRONG TO SUPPORT THE UNIT WEIGHT.
 - PROVIDE A FLOOR DRAIN NEAR CHILLER FOUNDATION.
 - ONLY IF FOUNDATION ANCHORING IS REQUIRED, ANCHOR BOLTS, NUTS AND WASHERS, SHALL BE SUPPLIED TOGETHER WITH CHILLER. ANCHOR BOLTS MUST BE FIXED ON THE FOUNDATION PRIOR TO CHILLER INSTALLATION
 - UNIT MUST BE LEVELED BEFORE STARTUP.
(HORIZONTAL LEVEL MUST BE BELOW THAN 2mm/1000mm)

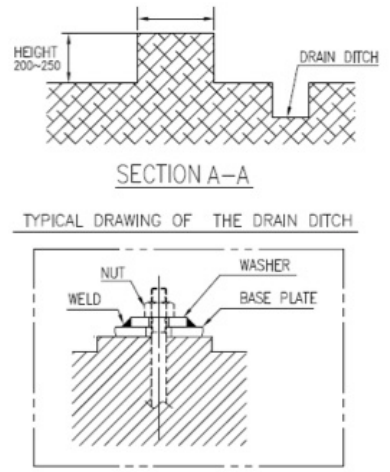

Model	Hot Water Capacity 10 ⁴ kcal/h	Dimension(mm)									
		A	B	C	D	E	F	G	H	J	W(ton)
WCPX196	1,960	4,951	2,100	5,000	520	200	320	2,300	260	200	20.7
WCPX230	2,300	4,951	2,300	5,400	520	200	320	2,500	260	200	24.1
WCPX260	2,600	5,461	2,500	5,800	520	200	320	2,700	260	200	27.9

WCPX003~WCPX082

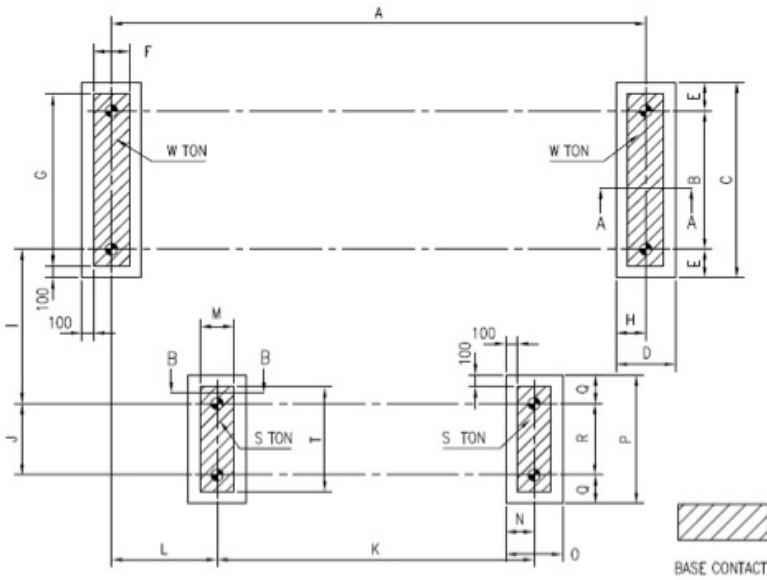

NOTE.

1. ◆ INDICATES THE POSITION OF ANCHOR BOLTS.
2. THE FOUNDATION AND THE FLOOR MUST BE SUFFICIENTLY STRONG TO SUPPORT THE UNIT WEIGHT.
3. PROVIDE A FLOOR DRAIN NEAR CHILLER FOUNDATION.
4. ONLY IF FOUNDATION ANCHORING IS REQUIRED, ANCHOR BOLTS, NUTS AND WASHERS, SHALL BE SUPPLIED TOGETHER WITH CHILLER. ANCHOR BOLTS MUST BE FIXED ON THE FOUNDATION PRIOR TO CHILLER INSTALLATION.
5. UNIT MUST BE LEVELED BEFORE STARTUP.
(HORIZONTAL LEVEL MUST BE BELOW THAN 2mm/1000mm)

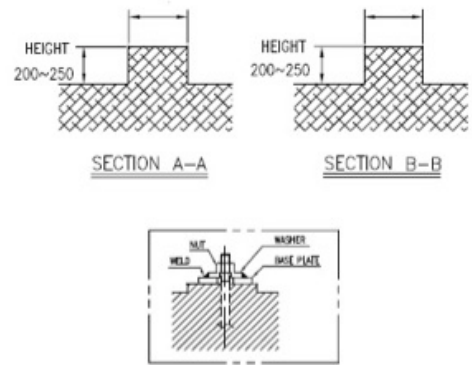

Model	Hot Water Capacity 10 ⁴ kcal/h	Dimension(mm)																				S (Ton)	W (Ton)
		A	B	C	D	E	F	G	H	I	J	K	L	M	N	O	P	Q	R	T			
WCPX003	30	1,470	820	1,140	295	160	95	940	147.5	258	220	970	698	100	100	200	540	160	220	340	0.8	1.45	
WCPX007	70	1,926	820	1,220	345	200	145	1,020	172.5	577	300	1,330	425	130	160	330	750	225	300	440	0.9	1.90	
WCPX010	100	1,926	820	1,220	345	200	145	1,020	172.5	547	350	1,350	440	170	185	370	750	200	350	550	0.9	2.10	
WCPX015	150	2,946	820	1,220	345	200	145	1,020	172.5	559	350	1,850	672	170	185	370	750	200	350	550	1.3	2.65	
WCPX020	200	2,816	980	1,380	470	200	270	1,180	235	549	460	1,954	716	220	210	420	820	185	460	620	1.6	3.45	
WCPX026	260	3,836	980	1,380	470	200	270	1,180	235	557	550	2,250	830	220	210	420	920	185	550	720	2.1	4.30	
WCPX033	330	3,836	1,040	1,440	470	200	270	1,240	235	480	960	2,250	1,165	200	200	400	1,320	180	960	1,120	2.8	5.35	
WCPX040	400	3,836	1,160	1,560	470	200	270	1,360	235	460	1,160	2,400	1,328	300	250	500	1,520	180	1,160	1,320	3.4	6.55	
WCPX052	520	4,378	1,600	2,000	470	200	270	1,800	235	460	1,160	3,000	1,328	300	250	500	1,520	180	1,160	1,320	5.0	9.90	
WCPX066	660	4,328	1,800	2,200	520	200	320	2,000	260	750	1,260	3,400	0	300	250	500	1,620	180	1,260	1,420	7.0	12.65	
WCPX082	820	5,351	1,800	2,200	520	200	320	2,000	260	800	1,340	3,700	0	300	250	500	1,700	180	1,340	1,500	10.5	17.45	

Heating mode (60°C)

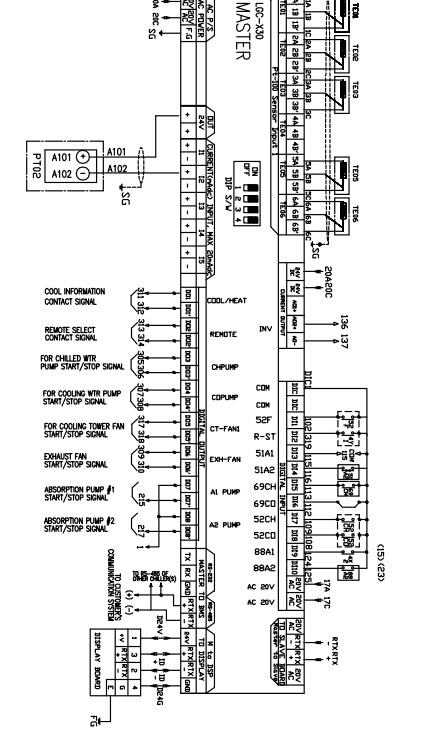
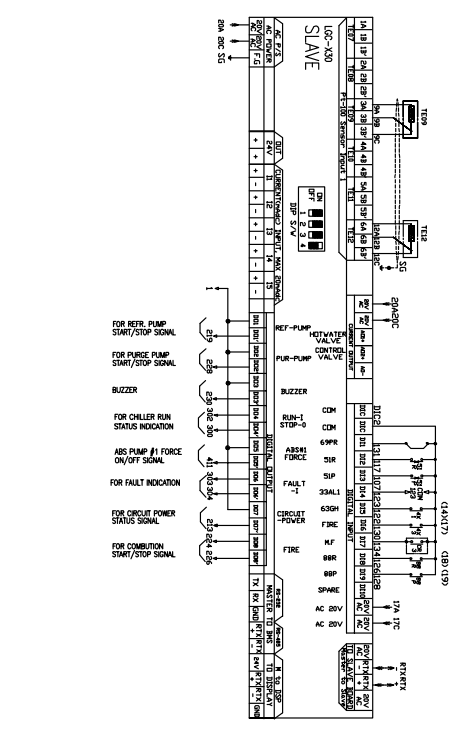
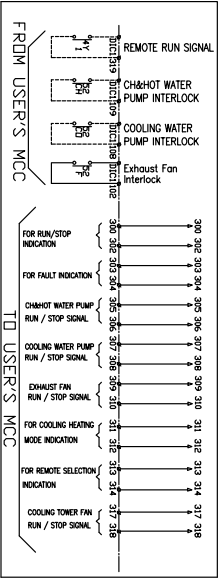
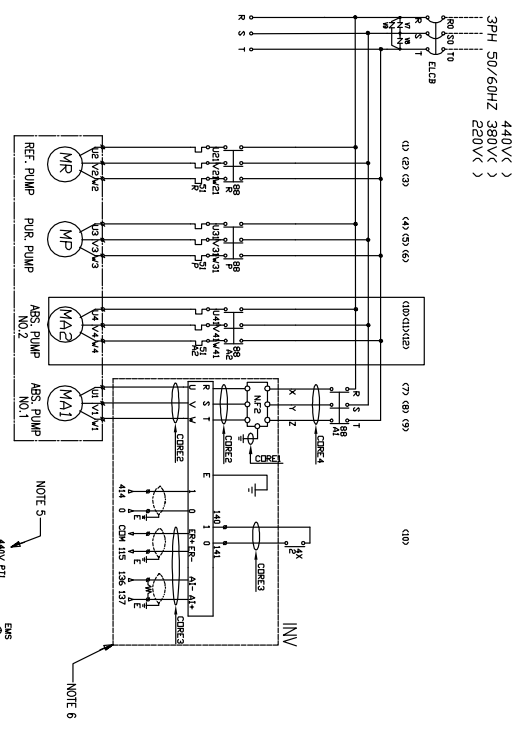
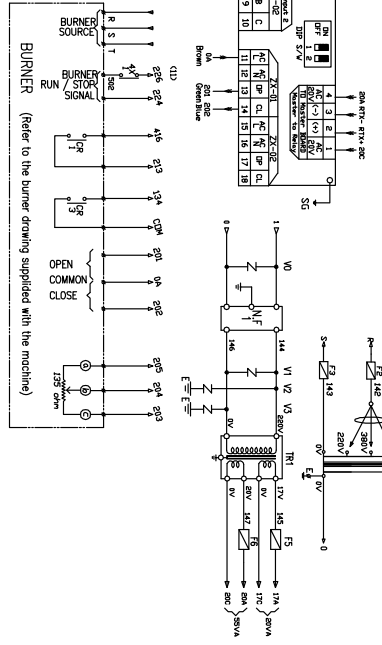
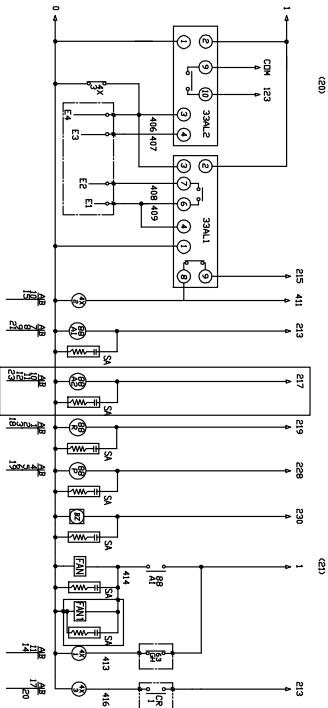

Power	V	A
380	4	4
220	4	4
120	4	4

Division	100T ~ 500RT (560RT ~ 900RT)	1500RT (1750VA)	2500RT (3000VA)	3500RT (4000VA)
F1	1	1	1	1
F2	1	1	1	1
F3	1	1	1	1
F4	1	1	1	1
F5	1	1	1	1
F6	1	1	1	1
F7	1	1	1	1
F8	1	1	1	1
F9	1	1	1	1
F10	1	1	1	1
F11	1	1	1	1
F12	1	1	1	1
F13	1	1	1	1
F14	1	1	1	1
F15	1	1	1	1
F16	1	1	1	1
F17	1	1	1	1
F18	1	1	1	1
F19	1	1	1	1
F20	1	1	1	1
F21	1	1	1	1
F22	1	1	1	1
F23	1	1	1	1
F24	1	1	1	1
F25	1	1	1	1
F26	1	1	1	1
F27	1	1	1	1
F28	1	1	1	1
F29	1	1	1	1
F30	1	1	1	1
F31	1	1	1	1
F32	1	1	1	1
F33	1	1	1	1
F34	1	1	1	1
F35	1	1	1	1
F36	1	1	1	1
F37	1	1	1	1
F38	1	1	1	1
F39	1	1	1	1
F40	1	1	1	1
F41	1	1	1	1
F42	1	1	1	1
F43	1	1	1	1
F44	1	1	1	1
F45	1	1	1	1
F46	1	1	1	1
F47	1	1	1	1
F48	1	1	1	1
F49	1	1	1	1
F50	1	1	1	1

- These points are supplied by burners.
- These points are installed on the CH&H&E body.
- These points are installed on the burner.
- These points are 560RT ~ 1500RT option.
- Transformers should be made according to main power supply (Standard type: 220V/380V/440V). Otherwise are special standard transformer with main power decided.
- Terminal No. of Inverter.

NOTE

- These points are supplied by burners.
- These points are installed on the CH&H&E body.
- These points are installed on the burner.
- These points are 560RT ~ 1500RT option.
- Transformers should be made according to main power supply (Standard type: 220V/380V/440V). Otherwise are special standard transformer with main power decided.
- Terminal No. of Inverter.

SYMBOL	DESCRIPTION	REMARKS
T01	CH&H&E Hot Water T&P Sensor	PT1000mm
T02	CH&H&E Cold Water T&P Sensor	PT1000mm
T03	Condenser T&P Sensor	PT1000mm
T04	High Condenser T&P Sensor	PT1000mm
T05	Low Condenser T&P Sensor	PT1000mm
T06	Exhaust Gas T&P Sensor	PT1000mm
T07	Exhaust Gas T&P Sensor	PT1000mm
T08	Exhaust Gas T&P Sensor	PT1000mm
T09	Exhaust Gas T&P Sensor	PT1000mm
T10	Exhaust Gas T&P Sensor	PT1000mm
T11	Exhaust Gas T&P Sensor	PT1000mm
T12	Exhaust Gas T&P Sensor	PT1000mm
T13	Exhaust Gas T&P Sensor	PT1000mm
T14	Exhaust Gas T&P Sensor	PT1000mm
T15	Exhaust Gas T&P Sensor	PT1000mm
T16	Exhaust Gas T&P Sensor	PT1000mm
T17	Exhaust Gas T&P Sensor	PT1000mm
T18	Exhaust Gas T&P Sensor	PT1000mm
T19	Exhaust Gas T&P Sensor	PT1000mm
T20	Exhaust Gas T&P Sensor	PT1000mm
T21	Exhaust Gas T&P Sensor	PT1000mm
T22	Exhaust Gas T&P Sensor	PT1000mm
T23	Exhaust Gas T&P Sensor	PT1000mm
T24	Exhaust Gas T&P Sensor	PT1000mm
T25	Exhaust Gas T&P Sensor	PT1000mm
T26	Exhaust Gas T&P Sensor	PT1000mm
T27	Exhaust Gas T&P Sensor	PT1000mm
T28	Exhaust Gas T&P Sensor	PT1000mm
T29	Exhaust Gas T&P Sensor	PT1000mm
T30	Exhaust Gas T&P Sensor	PT1000mm
T31	Exhaust Gas T&P Sensor	PT1000mm
T32	Exhaust Gas T&P Sensor	PT1000mm
T33	Exhaust Gas T&P Sensor	PT1000mm
T34	Exhaust Gas T&P Sensor	PT1000mm
T35	Exhaust Gas T&P Sensor	PT1000mm
T36	Exhaust Gas T&P Sensor	PT1000mm
T37	Exhaust Gas T&P Sensor	PT1000mm
T38	Exhaust Gas T&P Sensor	PT1000mm
T39	Exhaust Gas T&P Sensor	PT1000mm
T40	Exhaust Gas T&P Sensor	PT1000mm
T41	Exhaust Gas T&P Sensor	PT1000mm
T42	Exhaust Gas T&P Sensor	PT1000mm
T43	Exhaust Gas T&P Sensor	PT1000mm
T44	Exhaust Gas T&P Sensor	PT1000mm
T45	Exhaust Gas T&P Sensor	PT1000mm
T46	Exhaust Gas T&P Sensor	PT1000mm
T47	Exhaust Gas T&P Sensor	PT1000mm
T48	Exhaust Gas T&P Sensor	PT1000mm
T49	Exhaust Gas T&P Sensor	PT1000mm
T50	Exhaust Gas T&P Sensor	PT1000mm

Heating mode (80°C)

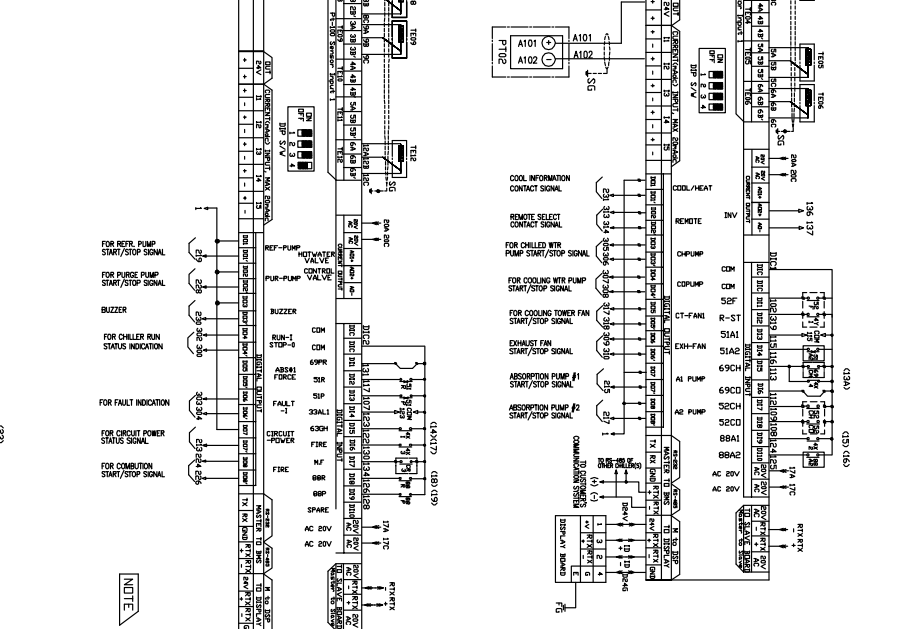
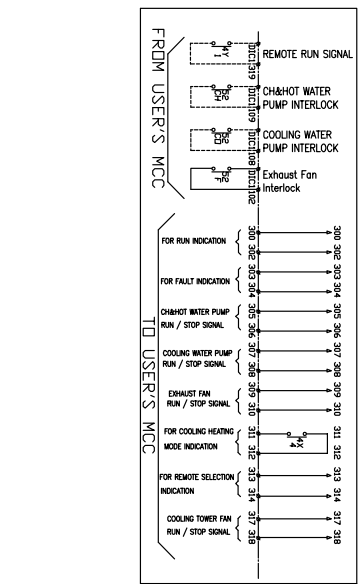
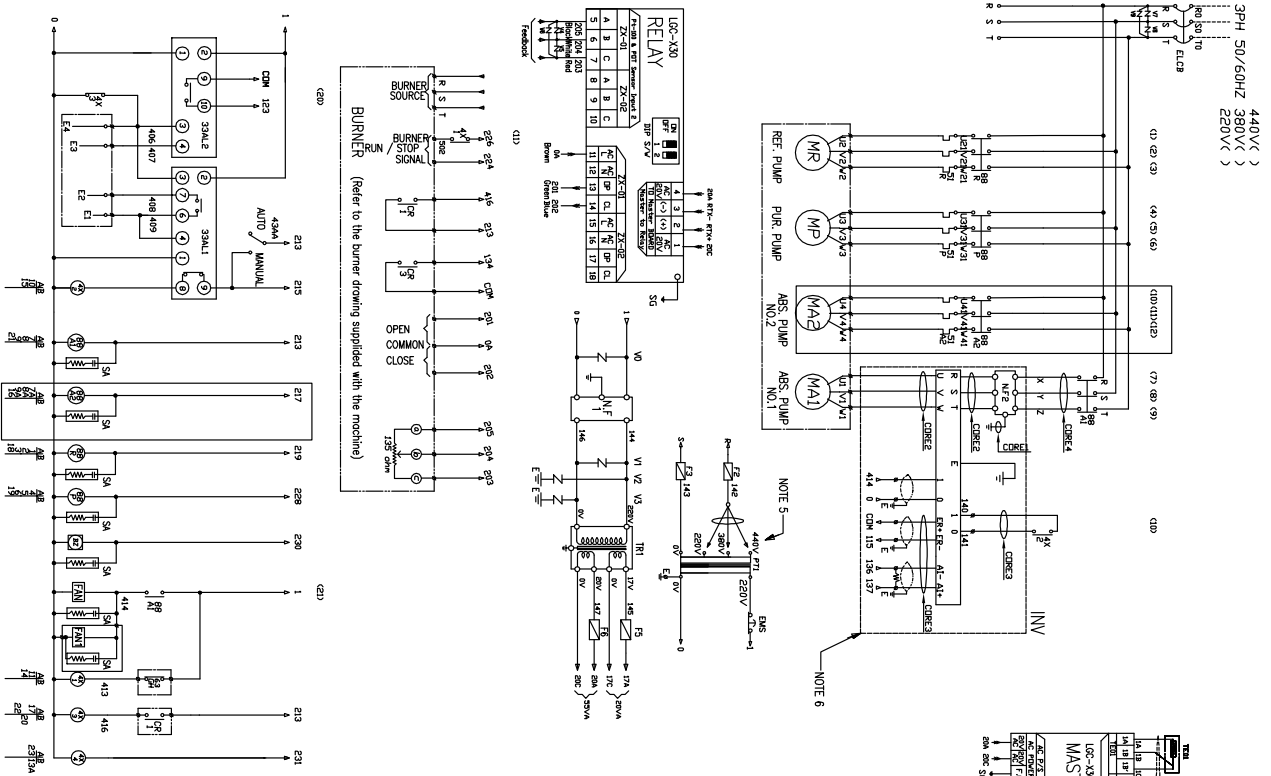

NOTE

- These parts are supplied by buyers
- These parts are included on the Chiller body
- These parts are included on the burner
- These parts are 500mm-1500mm adoption.
- Transformers should be made according to main power supply voltage and power capacity. One who should be considered accordance with main power decided.
- Terminal No. of Inverter

SYMBOL	DESCRIPTION	REMARKS
T01	Oil Water Inlet TMR Sensor	PT1000mm
T02	Oil Water Outlet TMR Sensor	PT1000mm
T03	Cooling Water Inlet TMR Sensor	PT1000mm
T04	Cooling Water TMR Sensor	PT1000mm
T05	High Condenser TMR Sensor	PT1000mm
T06	Low Condenser TMR Sensor	PT1000mm
T07	Hot Water Outlet TMR Sensor	PT1000mm
T08	Hot Water Inlet TMR Sensor	PT1000mm
T09	Hot Water TMR Sensor	PT1000mm
T10	Exhaust Gas TMR Sensor	PT1000mm
T11	Water TMR Sensor	PT1000mm
T12	Water TMR Sensor	PT1000mm
T13	Water TMR Sensor	PT1000mm
T14	Water TMR Sensor	PT1000mm
T15	Water TMR Sensor	PT1000mm
T16	Water TMR Sensor	PT1000mm
T17	Water TMR Sensor	PT1000mm
T18	Water TMR Sensor	PT1000mm
T19	Water TMR Sensor	PT1000mm
T20	Water TMR Sensor	PT1000mm
T21	Water TMR Sensor	PT1000mm
T22	Water TMR Sensor	PT1000mm
T23	Water TMR Sensor	PT1000mm
T24	Water TMR Sensor	PT1000mm
T25	Water TMR Sensor	PT1000mm
T26	Water TMR Sensor	PT1000mm
T27	Water TMR Sensor	PT1000mm
T28	Water TMR Sensor	PT1000mm
T29	Water TMR Sensor	PT1000mm
T30	Water TMR Sensor	PT1000mm
T31	Water TMR Sensor	PT1000mm
T32	Water TMR Sensor	PT1000mm
T33	Water TMR Sensor	PT1000mm
T34	Water TMR Sensor	PT1000mm
T35	Water TMR Sensor	PT1000mm
T36	Water TMR Sensor	PT1000mm
T37	Water TMR Sensor	PT1000mm
T38	Water TMR Sensor	PT1000mm
T39	Water TMR Sensor	PT1000mm
T40	Water TMR Sensor	PT1000mm
T41	Water TMR Sensor	PT1000mm
T42	Water TMR Sensor	PT1000mm
T43	Water TMR Sensor	PT1000mm
T44	Water TMR Sensor	PT1000mm
T45	Water TMR Sensor	PT1000mm
T46	Water TMR Sensor	PT1000mm
T47	Water TMR Sensor	PT1000mm
T48	Water TMR Sensor	PT1000mm
T49	Water TMR Sensor	PT1000mm
T50	Water TMR Sensor	PT1000mm
T51	Water TMR Sensor	PT1000mm
T52	Water TMR Sensor	PT1000mm
T53	Water TMR Sensor	PT1000mm
T54	Water TMR Sensor	PT1000mm
T55	Water TMR Sensor	PT1000mm
T56	Water TMR Sensor	PT1000mm
T57	Water TMR Sensor	PT1000mm
T58	Water TMR Sensor	PT1000mm
T59	Water TMR Sensor	PT1000mm
T60	Water TMR Sensor	PT1000mm
T61	Water TMR Sensor	PT1000mm
T62	Water TMR Sensor	PT1000mm
T63	Water TMR Sensor	PT1000mm
T64	Water TMR Sensor	PT1000mm
T65	Water TMR Sensor	PT1000mm
T66	Water TMR Sensor	PT1000mm
T67	Water TMR Sensor	PT1000mm
T68	Water TMR Sensor	PT1000mm
T69	Water TMR Sensor	PT1000mm
T70	Water TMR Sensor	PT1000mm
T71	Water TMR Sensor	PT1000mm
T72	Water TMR Sensor	PT1000mm
T73	Water TMR Sensor	PT1000mm
T74	Water TMR Sensor	PT1000mm
T75	Water TMR Sensor	PT1000mm
T76	Water TMR Sensor	PT1000mm
T77	Water TMR Sensor	PT1000mm
T78	Water TMR Sensor	PT1000mm
T79	Water TMR Sensor	PT1000mm
T80	Water TMR Sensor	PT1000mm
T81	Water TMR Sensor	PT1000mm
T82	Water TMR Sensor	PT1000mm
T83	Water TMR Sensor	PT1000mm
T84	Water TMR Sensor	PT1000mm
T85	Water TMR Sensor	PT1000mm
T86	Water TMR Sensor	PT1000mm
T87	Water TMR Sensor	PT1000mm
T88	Water TMR Sensor	PT1000mm
T89	Water TMR Sensor	PT1000mm
T90	Water TMR Sensor	PT1000mm
T91	Water TMR Sensor	PT1000mm
T92	Water TMR Sensor	PT1000mm
T93	Water TMR Sensor	PT1000mm
T94	Water TMR Sensor	PT1000mm
T95	Water TMR Sensor	PT1000mm
T96	Water TMR Sensor	PT1000mm
T97	Water TMR Sensor	PT1000mm
T98	Water TMR Sensor	PT1000mm
T99	Water TMR Sensor	PT1000mm
T100	Water TMR Sensor	PT1000mm

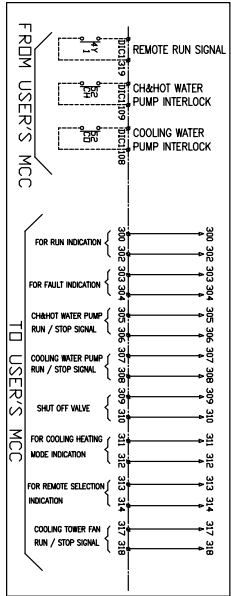
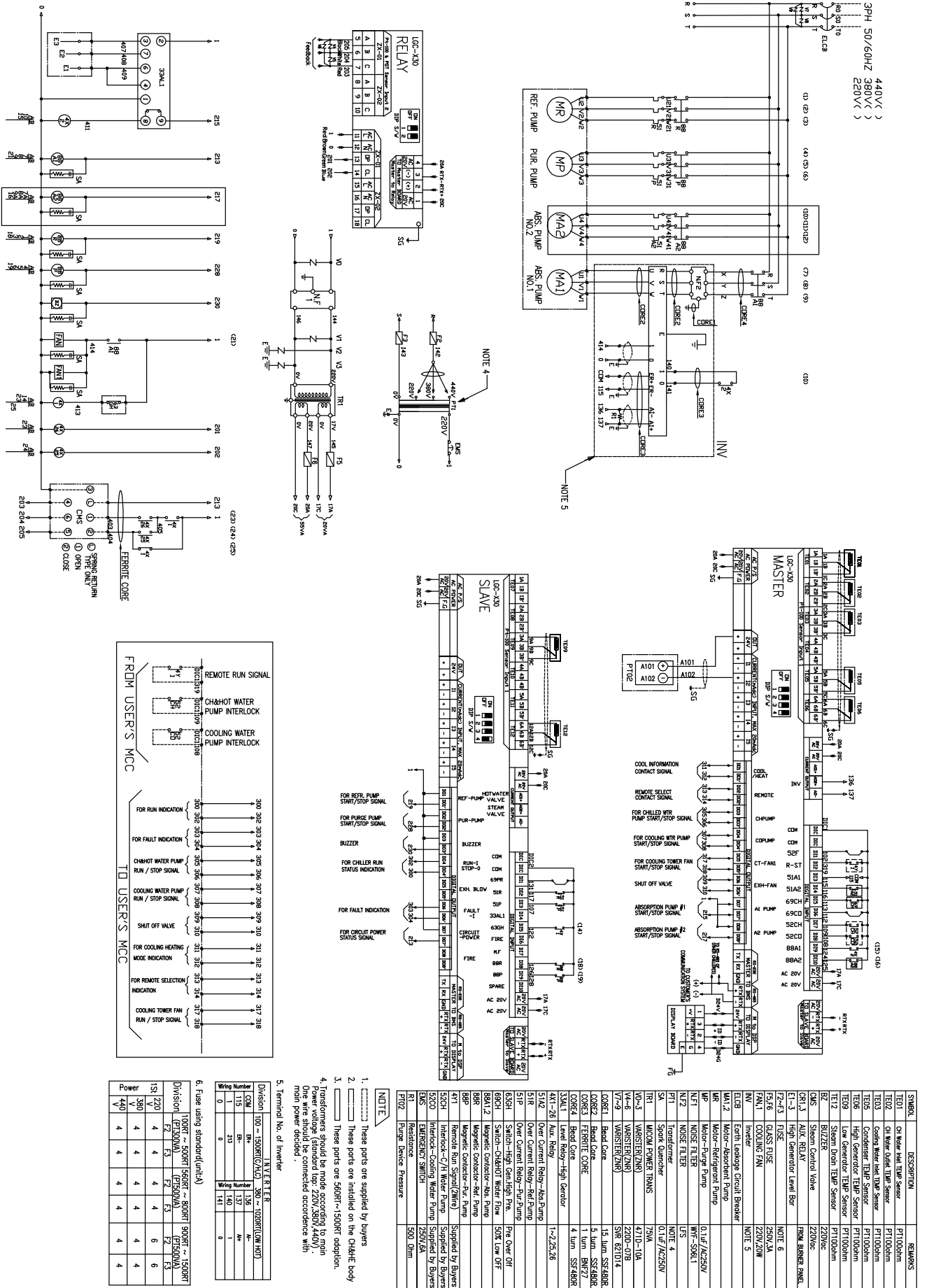

1. These parts are supplied by Buyers.
2. These parts are indicated on the Chiller body.
3. These parts are 560RT (~1500RT adaption).
4. Transformers should be made according to main Power voltage (standard tap: 220V, 380V, 440V). One wire should be connected accordance with main power decided.
5. Terminal No. of Inverter.

Division	100 ~ 1500RT (C.A.D.)	380 ~ 10000RT (C.W. 100T)
Wiring Number	135	M
115	137	M
2	0	0
Wiring Number	141	0

SYMBOL	DESCRIPTION	REMARKS
TE01	Oil Water Heat Tap Sensor	PT100ohm
TE02	Oil Water Outlet Temp Sensor	PT100ohm
TE03	Cooling Water Inlet Temp Sensor	PT100ohm
TE04	Condenser Temp Sensor	PT100ohm
TE05	High Generator Temp Sensor	PT100ohm
TE06	Lam Generator Temp Sensor	PT100ohm
TE09	Steam Drain Temp Sensor	PT100ohm
TE12	Steam Drain Temp Sensor	PT200ohm
BZ	Buzzer	220V/6c
CRS	Steam Control Valve	PNW 450mm DN25
EL-3	High Generator Level Bar	
FZ-F3	FUSE	NOTE 6
FZ-F6	CLASS FUSE	250V/3A
FWA1	COOLING FAN	220V/20W
INV	Inverter	NOTE 5
ELB2	Earth Leakage Circuit Breaker	
MK1.2	Motor-Absorbent Pump	
MK2	Motor-Fetigate Pump	0.1HP/AC220V
MP	Motor-Fetigate Pump	WFF-S00M11
N1	NOISE FILTER	WFF-S00M11
N2	NOISE FILTER	US
N3	NOISE FILTER	US
PT1	Transformer	NOTE 4
SP4	Spoke Quarter	0.1HP/AC220V
SR1	MICRO POWER TRANS	75W
TR-3	WASHTER(ZNS)	4710-10A
VA-6	WASHTER(ZNS)	220V-07B
VV-9	WASHTER(ZNS)	50V 021014
LCOR1	Head Core	1.5 Lum SS430R
LCOR2	Head Core	1 Lum SS430R
LCOR3	Head Core	1 Lum SS430R
LCOR4	Head Core	4 Lum SS430R
EX-1	Exhaust Fan	4 Lum SS430R
AXY-26	Flux Relay	1-2, 25, 26

WCMW003 - WCMW034

POWER SUPPLY 440V ()
3PH 50/60HZ 380V ()
220V ()

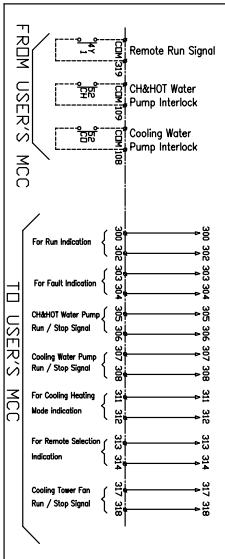
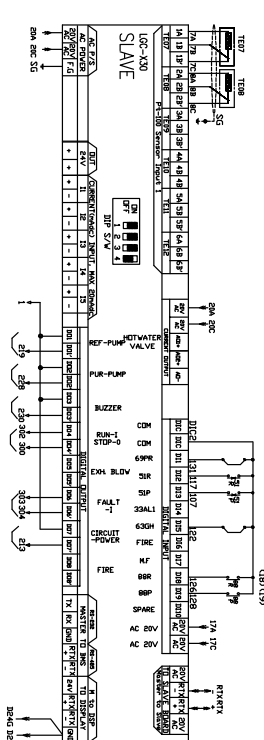
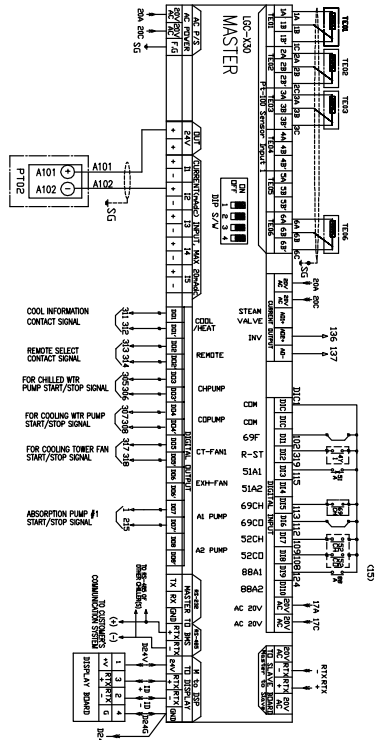
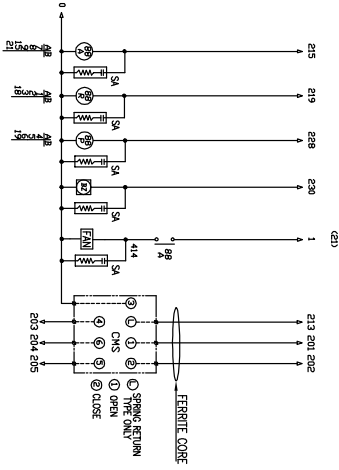
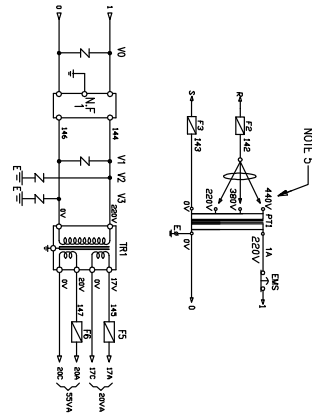
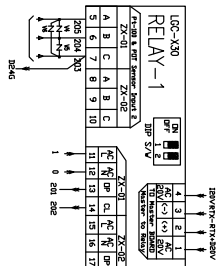
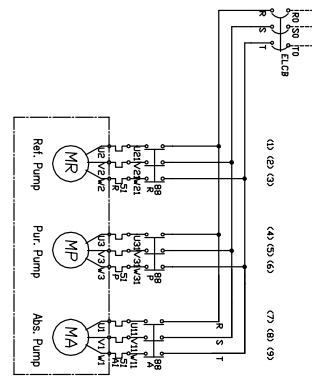

FOR REFR. PUMP START/STOP SIGNAL
FOR PURGE PUMP START/STOP SIGNAL
BUZZER
FOR CHILLER RUN STATUS INDICATION
FOR FAULT INDICATION
FOR CIRCUIT POWER STATUS SIGNAL

NOTE

1. These parts are supplied by buyers
2. These parts are installed on the CH&H body
3. These parts are installed on the burner
4. These parts are 560RT~1500RT adaption.
5. TRANSFORMERS SHOULD BE MADE ACCORDING TO MAIN POWER SUPPLY (380V/220V) AND MAIN POWER SUPPLY (50/60HZ) AND MAIN POWER DECIDED.

NO.	DESCRIPTION	REMARKS
TE01	CH Water Inlet Temp. Sensor	PT1000mm
TE02	CH Water Outlet Temp. Sensor	PT1000mm
TE03	Cooling Water Inlet Temp. Sensor	PT1000mm
TE04	Cooling Water Outlet Temp. Sensor	PT1000mm
TE05	CH Water Outlet Temp. Sensor	PT1000mm
TE06	CH Water Inlet Temp. Sensor	PT1000mm
TE07	CH&HOT Water Inlet Temp. Sensor	PT1000mm
TE08	CH&HOT Water Outlet Temp. Sensor	PT1000mm
BZ	Buzzer	220V/0.1A
CVS	System Control Valve	2A
F1	FUSE	250V/3A
F2	FUSE	250V/3A
F3	FUSE	250V/3A
F4	FUSE	250V/3A
F5	FUSE	250V/3A
F6	FUSE	250V/3A
F7	FUSE	250V/3A
F8	FUSE	250V/3A
F9	FUSE	250V/3A
F10	FUSE	250V/3A
F11	FUSE	250V/3A
F12	FUSE	250V/3A
F13	FUSE	250V/3A
F14	FUSE	250V/3A
F15	FUSE	250V/3A
F16	FUSE	250V/3A
F17	FUSE	250V/3A
F18	FUSE	250V/3A
F19	FUSE	250V/3A
F20	FUSE	250V/3A
F21	FUSE	250V/3A
F22	FUSE	250V/3A
F23	FUSE	250V/3A
F24	FUSE	250V/3A
F25	FUSE	250V/3A
F26	FUSE	250V/3A
F27	FUSE	250V/3A
F28	FUSE	250V/3A
F29	FUSE	250V/3A
F30	FUSE	250V/3A
F31	FUSE	250V/3A
F32	FUSE	250V/3A
F33	FUSE	250V/3A
F34	FUSE	250V/3A
F35	FUSE	250V/3A
F36	FUSE	250V/3A
F37	FUSE	250V/3A
F38	FUSE	250V/3A
F39	FUSE	250V/3A
F40	FUSE	250V/3A
F41	FUSE	250V/3A
F42	FUSE	250V/3A
F43	FUSE	250V/3A
F44	FUSE	250V/3A
F45	FUSE	250V/3A
F46	FUSE	250V/3A
F47	FUSE	250V/3A
F48	FUSE	250V/3A
F49	FUSE	250V/3A
F50	FUSE	250V/3A
F51	FUSE	250V/3A
F52	FUSE	250V/3A
F53	FUSE	250V/3A
F54	FUSE	250V/3A
F55	FUSE	250V/3A
F56	FUSE	250V/3A
F57	FUSE	250V/3A
F58	FUSE	250V/3A
F59	FUSE	250V/3A
F60	FUSE	250V/3A
F61	FUSE	250V/3A
F62	FUSE	250V/3A
F63	FUSE	250V/3A
F64	FUSE	250V/3A
F65	FUSE	250V/3A
F66	FUSE	250V/3A
F67	FUSE	250V/3A
F68	FUSE	250V/3A
F69	FUSE	250V/3A
F70	FUSE	250V/3A
F71	FUSE	250V/3A
F72	FUSE	250V/3A
F73	FUSE	250V/3A
F74	FUSE	250V/3A
F75	FUSE	250V/3A
F76	FUSE	250V/3A
F77	FUSE	250V/3A
F78	FUSE	250V/3A
F79	FUSE	250V/3A
F80	FUSE	250V/3A
F81	FUSE	250V/3A
F82	FUSE	250V/3A
F83	FUSE	250V/3A
F84	FUSE	250V/3A
F85	FUSE	250V/3A
F86	FUSE	250V/3A
F87	FUSE	250V/3A
F88	FUSE	250V/3A
F89	FUSE	250V/3A
F90	FUSE	250V/3A
F91	FUSE	250V/3A
F92	FUSE	250V/3A
F93	FUSE	250V/3A
F94	FUSE	250V/3A
F95	FUSE	250V/3A
F96	FUSE	250V/3A
F97	FUSE	250V/3A
F98	FUSE	250V/3A
F99	FUSE	250V/3A
F100	FUSE	250V/3A

WCMW038-WCMW102

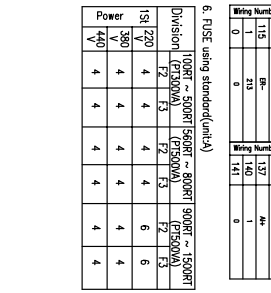
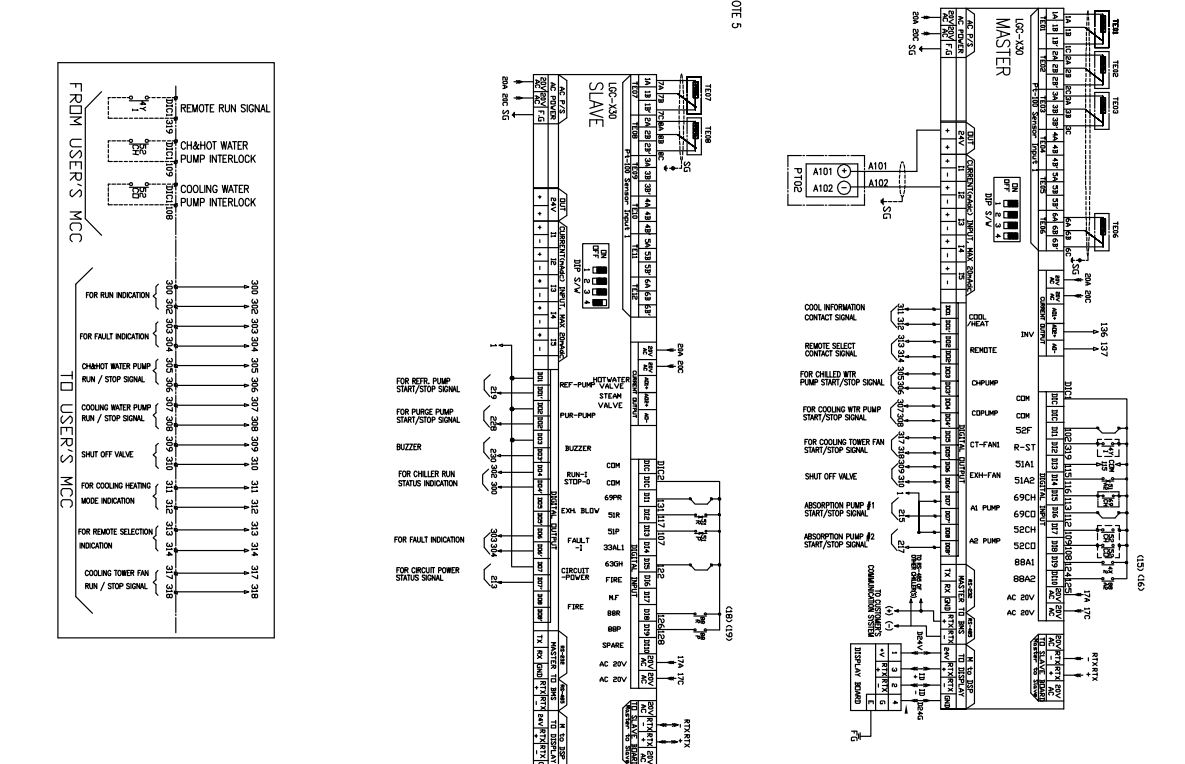
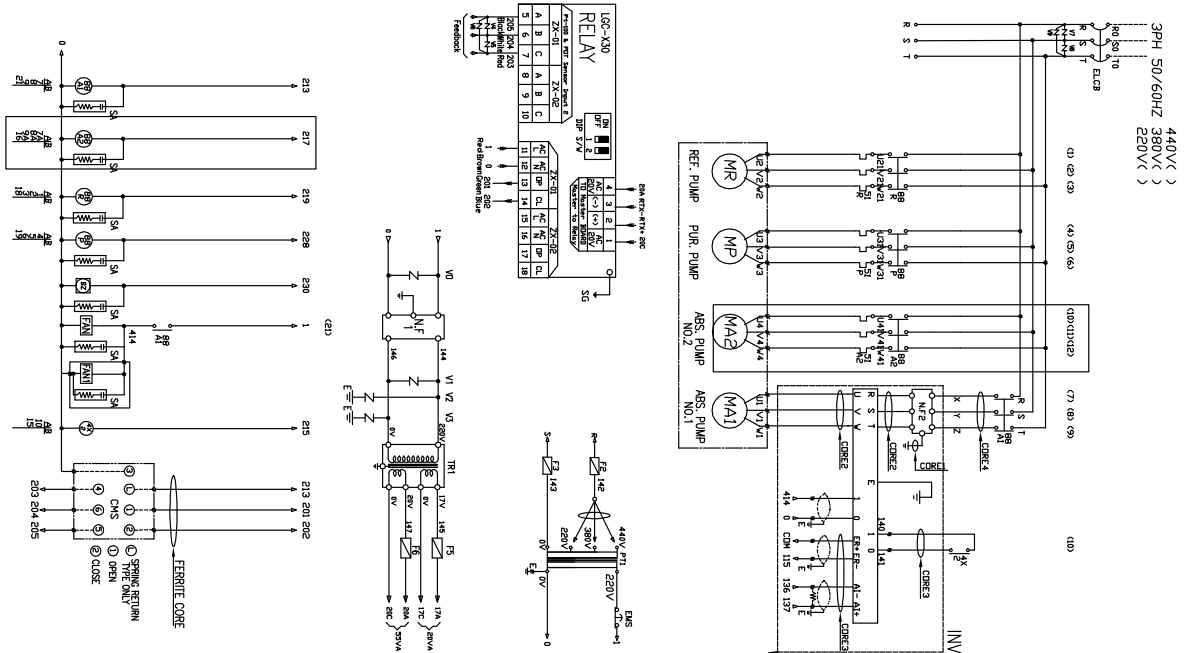

- NOTE**
- These ports are supplied by buyers
 - These ports are installed on the Chiller body
 - These ports are 580RT ~ 1500RT defraction.
 - Transformers should be made according to main Power voltage (standard tap: 220V, 380V, 440V). One wire should be connected accordance with main power decided.
 - Terminal No. of Inverter

SW/NO.	DESCRIPTION	REMARKS
TE01	Chiller High Temp. Sensor	PT1000ohm
TE02	Chiller Outlet Water Sensor	PT1000ohm
TE03	Cooling Water High Temp. Sensor	PT1000ohm
TE04	Generator High Temp. Sensor	PT1000ohm
TE05	Hot Water Outlet Temp. Sensor	PT1000ohm
TE06	Hot Water High Temp. Sensor	PT1000ohm
TE07	Hot Water High Temp. Sensor	PT1000ohm
TE08	Hot Water High Temp. Sensor	PT1000ohm
TE09	Hot Water High Temp. Sensor	PT1000ohm
TE10	Hot Water High Temp. Sensor	PT1000ohm
TE11	Hot Water High Temp. Sensor	PT1000ohm
TE12	Hot Water High Temp. Sensor	PT1000ohm
TE13	Hot Water High Temp. Sensor	PT1000ohm
TE14	Hot Water High Temp. Sensor	PT1000ohm
TE15	Hot Water High Temp. Sensor	PT1000ohm
TE16	Hot Water High Temp. Sensor	PT1000ohm
TE17	Hot Water High Temp. Sensor	PT1000ohm
TE18	Hot Water High Temp. Sensor	PT1000ohm
TE19	Hot Water High Temp. Sensor	PT1000ohm
TE20	Hot Water High Temp. Sensor	PT1000ohm
TE21	Hot Water High Temp. Sensor	PT1000ohm
TE22	Hot Water High Temp. Sensor	PT1000ohm
TE23	Hot Water High Temp. Sensor	PT1000ohm
TE24	Hot Water High Temp. Sensor	PT1000ohm
TE25	Hot Water High Temp. Sensor	PT1000ohm
TE26	Hot Water High Temp. Sensor	PT1000ohm
TE27	Hot Water High Temp. Sensor	PT1000ohm
TE28	Hot Water High Temp. Sensor	PT1000ohm
TE29	Hot Water High Temp. Sensor	PT1000ohm
TE30	Hot Water High Temp. Sensor	PT1000ohm
TE31	Hot Water High Temp. Sensor	PT1000ohm
TE32	Hot Water High Temp. Sensor	PT1000ohm
TE33	Hot Water High Temp. Sensor	PT1000ohm
TE34	Hot Water High Temp. Sensor	PT1000ohm
TE35	Hot Water High Temp. Sensor	PT1000ohm
TE36	Hot Water High Temp. Sensor	PT1000ohm
TE37	Hot Water High Temp. Sensor	PT1000ohm
TE38	Hot Water High Temp. Sensor	PT1000ohm
TE39	Hot Water High Temp. Sensor	PT1000ohm
TE40	Hot Water High Temp. Sensor	PT1000ohm
TE41	Hot Water High Temp. Sensor	PT1000ohm
TE42	Hot Water High Temp. Sensor	PT1000ohm
TE43	Hot Water High Temp. Sensor	PT1000ohm
TE44	Hot Water High Temp. Sensor	PT1000ohm
TE45	Hot Water High Temp. Sensor	PT1000ohm
TE46	Hot Water High Temp. Sensor	PT1000ohm
TE47	Hot Water High Temp. Sensor	PT1000ohm
TE48	Hot Water High Temp. Sensor	PT1000ohm
TE49	Hot Water High Temp. Sensor	PT1000ohm
TE50	Hot Water High Temp. Sensor	PT1000ohm
TE51	Hot Water High Temp. Sensor	PT1000ohm
TE52	Hot Water High Temp. Sensor	PT1000ohm
TE53	Hot Water High Temp. Sensor	PT1000ohm
TE54	Hot Water High Temp. Sensor	PT1000ohm
TE55	Hot Water High Temp. Sensor	PT1000ohm
TE56	Hot Water High Temp. Sensor	PT1000ohm
TE57	Hot Water High Temp. Sensor	PT1000ohm
TE58	Hot Water High Temp. Sensor	PT1000ohm
TE59	Hot Water High Temp. Sensor	PT1000ohm
TE60	Hot Water High Temp. Sensor	PT1000ohm
TE61	Hot Water High Temp. Sensor	PT1000ohm
TE62	Hot Water High Temp. Sensor	PT1000ohm
TE63	Hot Water High Temp. Sensor	PT1000ohm
TE64	Hot Water High Temp. Sensor	PT1000ohm
TE65	Hot Water High Temp. Sensor	PT1000ohm
TE66	Hot Water High Temp. Sensor	PT1000ohm
TE67	Hot Water High Temp. Sensor	PT1000ohm
TE68	Hot Water High Temp. Sensor	PT1000ohm
TE69	Hot Water High Temp. Sensor	PT1000ohm
TE70	Hot Water High Temp. Sensor	PT1000ohm
TE71	Hot Water High Temp. Sensor	PT1000ohm
TE72	Hot Water High Temp. Sensor	PT1000ohm
TE73	Hot Water High Temp. Sensor	PT1000ohm
TE74	Hot Water High Temp. Sensor	PT1000ohm
TE75	Hot Water High Temp. Sensor	PT1000ohm
TE76	Hot Water High Temp. Sensor	PT1000ohm
TE77	Hot Water High Temp. Sensor	PT1000ohm
TE78	Hot Water High Temp. Sensor	PT1000ohm
TE79	Hot Water High Temp. Sensor	PT1000ohm
TE80	Hot Water High Temp. Sensor	PT1000ohm
TE81	Hot Water High Temp. Sensor	PT1000ohm
TE82	Hot Water High Temp. Sensor	PT1000ohm
TE83	Hot Water High Temp. Sensor	PT1000ohm
TE84	Hot Water High Temp. Sensor	PT1000ohm
TE85	Hot Water High Temp. Sensor	PT1000ohm
TE86	Hot Water High Temp. Sensor	PT1000ohm
TE87	Hot Water High Temp. Sensor	PT1000ohm
TE88	Hot Water High Temp. Sensor	PT1000ohm
TE89	Hot Water High Temp. Sensor	PT1000ohm
TE90	Hot Water High Temp. Sensor	PT1000ohm
TE91	Hot Water High Temp. Sensor	PT1000ohm
TE92	Hot Water High Temp. Sensor	PT1000ohm
TE93	Hot Water High Temp. Sensor	PT1000ohm
TE94	Hot Water High Temp. Sensor	PT1000ohm
TE95	Hot Water High Temp. Sensor	PT1000ohm
TE96	Hot Water High Temp. Sensor	PT1000ohm
TE97	Hot Water High Temp. Sensor	PT1000ohm
TE98	Hot Water High Temp. Sensor	PT1000ohm
TE99	Hot Water High Temp. Sensor	PT1000ohm
TE100	Hot Water High Temp. Sensor	PT1000ohm

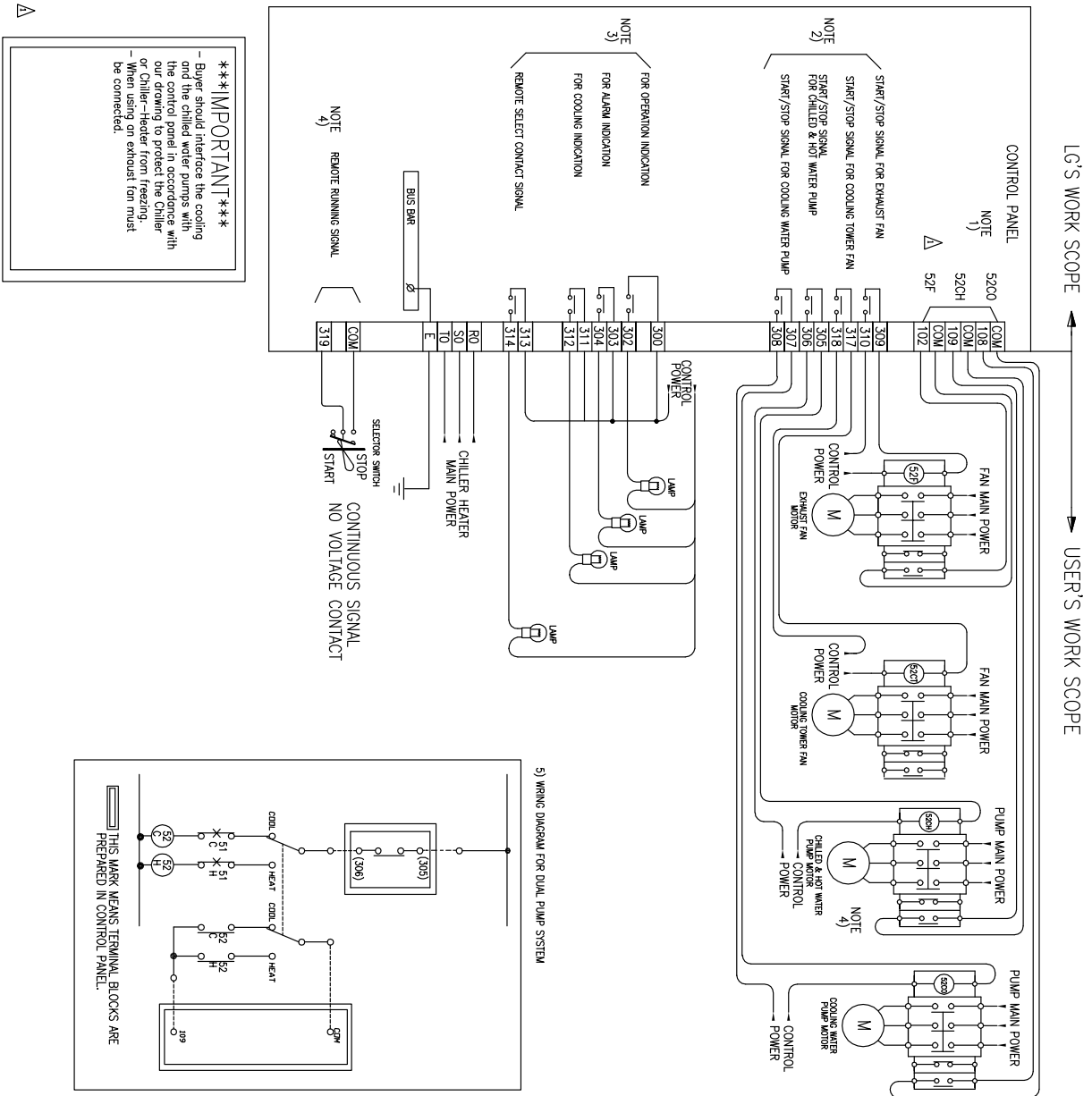

*****IMPORTANT*****

- Buyer should interface the cooling and the chilled water pumps with the control panel in accordance with our drawing to protect the Chiller or Chiller-Heater from freezing.
- When using an exhaust fan must be connected.

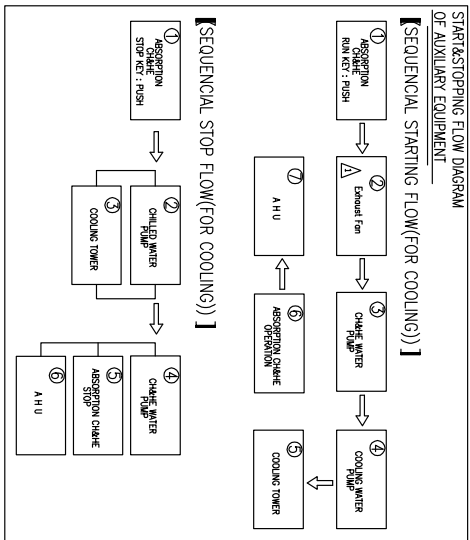
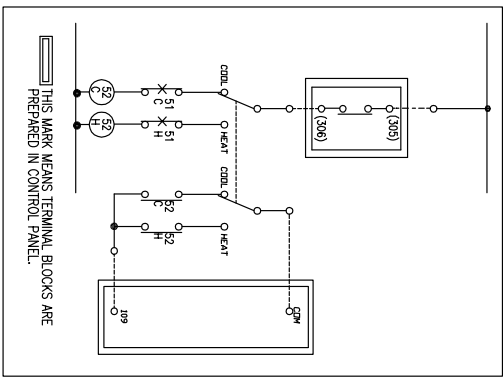

- NOTE**
- 1) THESE INTERLOCK CONTACTS SHALL BE SUPPLIED BY USER.
 - CONTACT DESCRIPTION : NO-VOLTAGE CONTACT(OR CONTACT)
 - ALLOWABLE CONTACT RESISTANCE : MAX. 100ohm
 - △ - When using an exhaust fan must be connected.
 - 2) THESE CONTACTS ARE FOR STARTING/STOPPING PERIPHERAL EQUIPMENT.
 - RATED CONTACT : BELOW 250Vdc, 0.1A
 - 3) THESE CONTACTS ARE FOR INDICATION OF CHILLER OR CHILLER OPERATION.
 - RATED CONTACT : BELOW 250Vdc, 0.1A
 - 4) THESE SIGNALS SHALL BE SUPPLIED BY USER.
- | ITEM | KINDS OF OUTPUT |
|-------|--|
| CH/HE | OPERATION, STOP, ALARM, COOLING, HEATING, COMBUSTION |

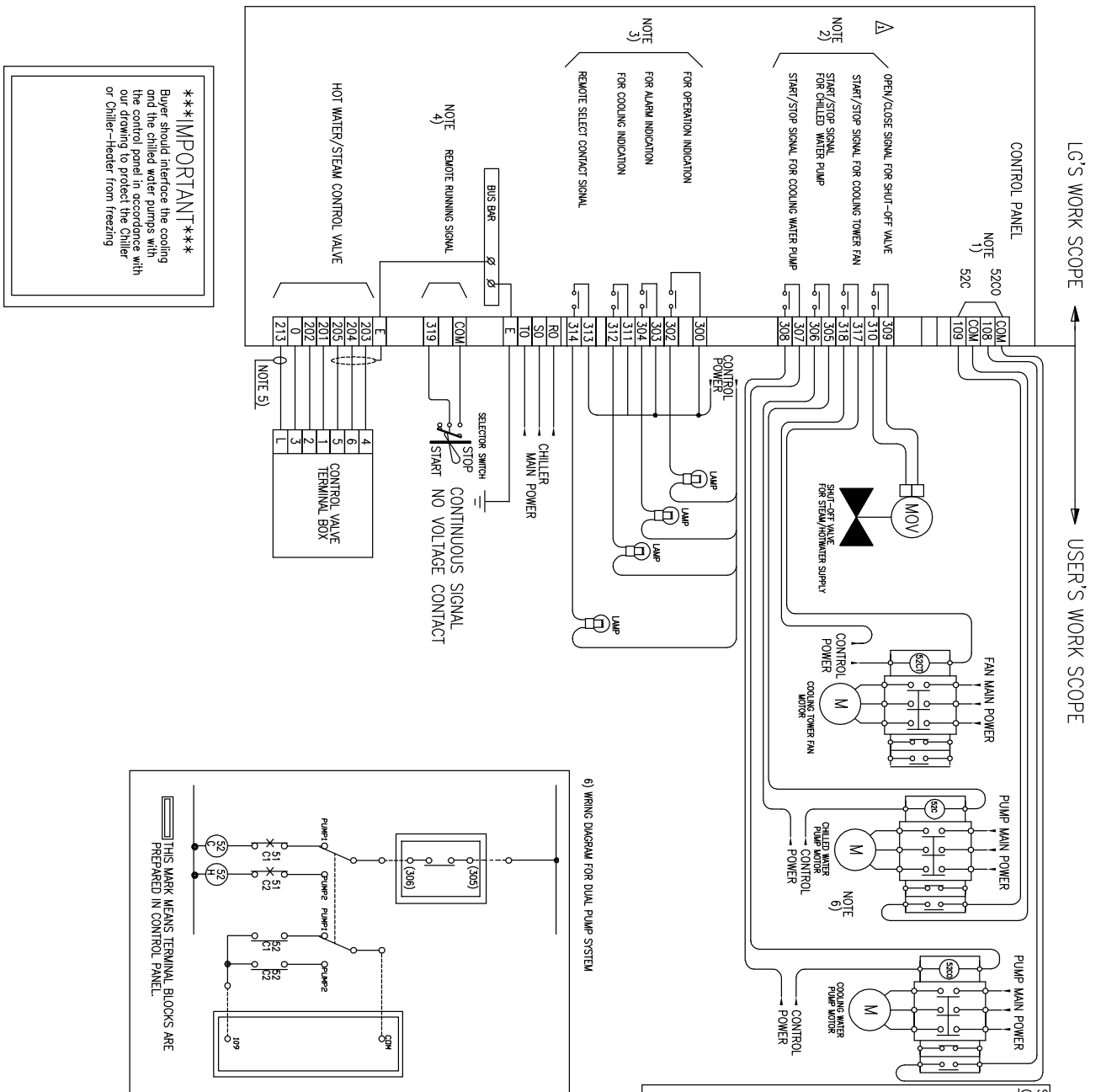

*****IMPORTANT*****
Buyer should interface the cooling and the chilled water pumps with our drawing to protect the Chiller or Chiller-Header from freezing

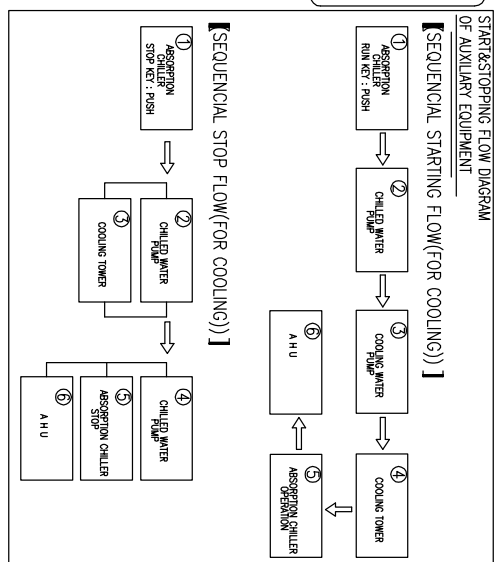
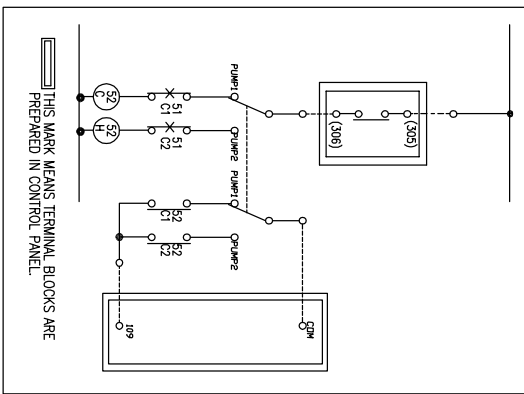

- NOTE**
- 1) THESE INTERLOCK CONTACTS SHALL BE SUPPLIED BY THE USER.
- CONTACT DESCRIPTION : NO-VOLTAGE CONTACT(DRY CONTACT)
- ALLOWABLE CONTACT RESISTANCE : MAX. 100ohm
 - 2) THESE CONTACTS ARE FOR STARTING/STOPPING THE THERMICAL EQUIPMENT.
- RATED CONTACT : BELOW 250vac, 0.1A
 - 3) THESE CONTACTS ARE FOR INDICATION OF THE CHILLER OPERATION.
- RATED CONTACT : BELOW 250vac, 0.1A
 - 4) THESE SIGNALS SHALL BE SUPPLIED BY USER.
 - 5) THIS WIRE IS FOR ONLY SPRING RETURN TYPE VALVE.



LG Electronics, Home appliance & Air solution company

Two IFC, 10 Gukjegeumyung-ro, Yeongdeungpo-gu, Seoul, 150-945, Korea.

www.lg.com

www.lgeaircon.com